



MOTO GUZZI®

PROUDLY AUTHENTIC MOTORCYCLES. SINCE 1921.

SERVICE STATION MANUAL

2Q000541



V100 E5



SERVICE STATION MANUAL

V100 E5

THE VALUE OF SERVICE

As a result of continuous updates and specific technical training programmes for Moto Guzzi products, only **Moto Guzzi** Official Network mechanics know this vehicle fully and have the specific tools necessary to carry out maintenance and repair operations correctly.

The reliability of the vehicle also depends on its mechanical conditions. Checking the vehicle before riding it, its regular maintenance and the use of **original Moto Guzzi spare parts** only are essential factors!

For information on the nearest **Official Dealer and/or Service Centre** consult our website:

www.motoguzzi.com

Only by requesting Moto Guzzi original spare parts can you be sure of purchasing products that were developed and tested during the actual vehicle design stage. All Moto Guzzi original spare parts undergo quality control procedures to guarantee reliability and durability.

The descriptions and images in this publication are given for illustrative purposes only and are not binding. While the basic characteristics as described and illustrated in this booklet remain unchanged, Piaggio & C. S.p.A. reserves the right, at any time and without being required to update this publication beforehand, to make any changes to components, parts or accessories, which it considers necessary to improve the product or which are required for manufacturing or construction reasons.

Not all versions/models shown in this publication are available in all countries. The availability of individual versions should be checked with the Official Moto Guzzi sales network.

The Moto Guzzi brand is owned by Piaggio & C. S.p.A.

© Copyright 2023 - Piaggio & C. S.p.A. All rights reserved. Reproduction of this publication in whole or in part is prohibited.

Piaggio & C. S.p.A. Viale Rinaldo Piaggio, 25 - 56025 PONTEDERA (PI), Italy

www.piaggio.com

SERVICE STATION MANUAL

V100 E5

This manual provides the main information to carry out regular maintenance operations on your vehicle. This manual is intended to **Moto Guzzi Dealers** and their qualified mechanics; several concepts have been deliberately omitted as they are considered unnecessary. As it is not possible to include complete mechanical notions in this manual, users should have basic mechanical knowledge or minimum knowledge about the procedures involved when repairing scooters. Without this knowledge, repairing or checking the vehicle may be inefficient or even dangerous. As the vehicle repair and check procedures are not described in detail, be extremely cautious so as not to damage components or injure individuals. In order to optimise customer satisfaction when using our vehicles, **Piaggio & C. s.p.a.** commits itself to continually improve its products and the relative documentation. The main technical modifications and changes in repair procedures are communicated to all **Moto Guzzi Sales Outlets and its International Subsidiaries**. These changes will be introduced in the subsequent editions of the manual. In case of need or further queries on repair and check procedures, consult **Moto Guzzi CUSTOMER DEPARTMENT**, which will be prepared to provide any information on the subject and any further communications on updates and technical changes related to the vehicle.

NOTE Provides key information to make the procedure easier to understand and carry out.

CAUTION Refers to specific procedures to carry out for preventing damages to the vehicle.

WARNING Refers to specific procedures to carry out to prevent injuries to the repairer.



Personal safety Failure to completely observe these instructions will result in serious risk of personal injury.



Safeguarding the environment Sections marked with this symbol indicate the correct use of the vehicle to prevent damaging the environment.



Vehicle intactness The incomplete or non-observance of these regulations leads to the risk of serious damage to the vehicle and sometimes even the invalidity of the guarantee



INDEX OF TOPICS

PRE-DELIVERY

PRE DE

CHARACTERISTICS

CCHAR

SPECIAL TOOLS

S-TOOLS

MAINTENANCE

MAIN

ELECTRICAL SYSTEM

ELE SYS

ENGINE FROM VEHICLE

ENG VE

ENGINE

ENG

POWER SUPPLY

P SUPP

SUSPENSIONS

SSUSP

CHASSIS

CCHAS

BRAKING SYSTEM

BRAK SYS

CLUATCH SYSTEM

CLU SYS

COOLING SYSTEM

COOOL SYS

BODYWORK

BODYW

INDEX OF TOPICS

PRE-DELIVERY

PRE DE

Carry out the listed tests before delivering the vehicle.

WARNING

PROCEED WITH THE UTMOST CAUTION WHEN HANDLING PETROL.

CAUTION

USE THE DIAGNOSTIC TOOL TO CHECK FOR ANY ERRORS AND CHECK THAT ALL PARAMETERS ARE CORRECT.

ENSURE THAT THE VEHICLE CALIBRATION HAS BEEN UPDATED TO LATEST VERSION AVAILABLE, AFTER UPDATING THE DIAGNOSTIC TOOL.

Aesthetic inspection

- Paintwork
 - Fitting of Plastics
 - Scratches
 - Dirt
-

Tightening torques inspection

Safety fasteners:

- Front and rear suspension assembly
 - Front and rear brake calliper clamping assembly
 - Front and rear wheel assembly
 - Engine - frame fastenings
 - Steering assembly
 - Plastics fixing screws
-

Electrical system

- Main switch
 - Headlamps: high beam lights, low beam lights, tail-lights (front and rear) and relevant warning lights
 - Headlight adjustment according to regulations in force
 - Front and rear stop light switches and their bulbs
 - Turn indicators and their warning lights
 - Instrument cluster lights
 - Instrument cluster: fuel and temperature indicator (if present)
 - Instrument panel warning lights
 - Horn
 - Electric starter
 - Engine stop via emergency stop switch and side stand
-

- Electric helmet compartment lock release switch (if applicable)
- Through the diagnostic tool, check that the last mapping version is present in the control unit/s and, if required, program the control unit/s again: consult the technical service website to know about available upgrades and details regarding the operation.

CAUTION

TO ENSURE MAXIMUM PERFORMANCE, THE BATTERY MUST BE CHARGED BEFORE USE. INADEQUATE CHARGING OF THE BATTERY WITH A LOW LEVEL OF ELECTROLYTE BEFORE IT IS FIRST USED SHORTENS THE LIFE OF THE BATTERY.

CAUTION

WHEN INSTALLING THE BATTERY, ATTACH THE POSITIVE LEAD FIRST AND THEN THE NEGATIVE ONE, AND PERFORM THE REVERSE OPERATION DURING REMOVAL.

CAUTION

THE BATTERY ELECTROLYTE IS TOXIC, CORROSIVE AND, AS IT CONTAINS SULPHURIC ACID, MAY CAUSE BURNING IF IT COMES INTO CONTACT WITH THE SKIN. WHEN HANDLING BATTERY ELECTROLYTE, WEAR TIGHT-FITTING GLOVES AND PROTECTIVE APPAREL. IN THE EVENT OF SKIN CONTACT WITH THE ELECTROLYTIC FLUID, RINSE WELL WITH PLENTY OF CLEAN WATER. IT IS PARTICULARLY IMPORTANT TO PROTECT YOUR EYES BECAUSE EVEN TINY AMOUNTS OF BATTERY ACID MAY CAUSE BLINDNESS. IN THE EVENT OF CONTACT WITH THE EYES, RINSE WITH PLENTY OF WATER FOR FIFTEEN MINUTES AND CONSULT AN EYE SPECIALIST IMMEDIATELY. THE BATTERY RELEASES EXPLOSIVE GASES; KEEP IT AWAY FROM FLAMES, SPARKS, CIGARETTES OR ANY OTHER HEAT SOURCES. ENSURE ADEQUATE VENTILATION WHEN SERVICING OR RECHARGING THE BATTERY.

KEEP OUT OF THE REACH OF CHILDREN.

BATTERY LIQUID IS CORROSIVE. DO NOT POUR OR SPILL ON PLASTIC COMPONENTS IN PARTICULAR. ENSURE THAT THE ELECTROLYTIC ACID IS COMPATIBLE WITH THE BATTERY BEING ACTIVATED.

CAUTION

NEVER USE FUSES WITH A CAPACITY HIGHER THAN THAT RECOMMENDED. THE USE OF A FUSE OF UNSUITABLE CAPACITY MAY RESULT IN SERIOUS DAMAGES TO THE WHOLE VEHICLE OR EVEN CAUSE A FIRE.

CAUTION

Do not leave the vehicle with the engine off and the ignition key to "ON". The sophisticated on-board instruments have a high current draw which, if left on with the engine switched off, will discharge the battery in a short time.

TRADITIONAL BATTERY ACTIVATION PROCEDURE

- Place the battery on a flat surface.
- Remove the cell's protective sticker.
- Take the acid container.
- Remove the cap 1 of the container 2.
- Place the container upside down, perpendicularly above the battery, aligning the outlets with the battery cells.
- Apply pressure to the container to break the seals. The liquid will begin to flow into the cells.

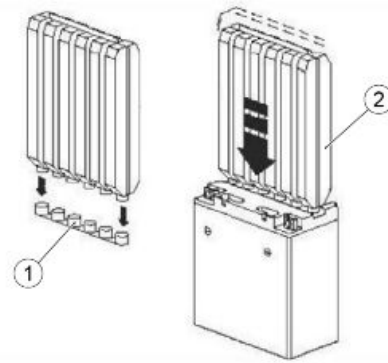

- Check that air bubbles come out of the cells; let the liquid flow into the cells for at least 20 minutes.
- If no air bubbles escape and the liquid does not flow, tap lightly on the bottom of the container until the liquid begins to flow into the cells. Never remove the container from the battery, pierce it or cut it to facilitate the exit of the liquid.
- Make sure the liquid container is completely empty before removing it.
- Allow the battery to stand for at least 1 hour, before starting the charging process, without closing the six cells. This operation is extremely important in order to have the best battery performance over time.
- Recharge the battery following the specifications indicated on the battery (see photo) and using a suitable battery charger.



NOTE

IN THE SHOWN EXAMPLE IT IS IMPORTANT TO USE A BATTERY CHARGER WITH 1.2 AMPERE (CHARGING TIME 5-10 HOURS) OR 5 AMPERE (CHARGING TIME 1 HOUR).

After performing the battery activation procedure, install it on the vehicle in the dedicated compartment. Then connect the cables to the battery, **starting from the positive (1).**



Install the battery cover (2) and tighten the fixing screws (3). Place the OBD2 cable (4) and the GMP preparation cable (5) on the cover.

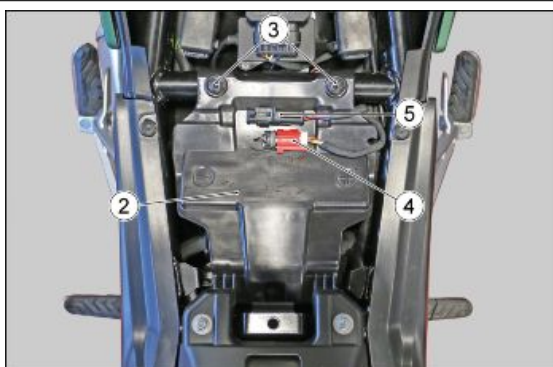

Levels check

- Braking system liquid level (front and rear)
- Hydraulic clutch fluid level
- Engine oil level
- Coolant level

Road test

- Cold start
- Instrument operations
- Throttle control response
- Stability on acceleration and braking
- Front and rear brake efficiency
- Front and rear suspension efficiency
- Abnormal noise

CAUTION



V100 is equipped with an advanced transmission that makes it easy to engage neutral between first and second gear when stationary. Due to the peculiar architecture of this transmission, **IT IS NOT POSSIBLE, AT A STANDSTILL, TO SHIFT INTO ANOTHER GEAR BEYOND THE FIRST GEAR.**

CAUTION



Do not leave the vehicle with the engine off and the ignition key to "ON". The sophisticated on-board instruments have a high current draw which, if left on with the engine switched off, will discharge the battery in a short time.

Static test

Static control after the test drive:

- Restarting when warmed up
- Minimum holding (turning the handlebar)
- Uniform turning of the steering
- Any leaks

CAUTION



Do not leave the vehicle with the engine off and the ignition key to "ON". The sophisticated on-board instruments have a high current draw which, if left on with the engine switched off, will discharge the battery in a short time.

Functional inspection

- Hydraulic braking system
- Brake and clutch lever stroke (where applicable)
- Clutch - check proper operation
- Engine - check for proper general operation and absence of abnormal noise
- Check documents, frame number and engine number
- Check included tools (where applicable)
- License plate fitting
- Locks check
- Tyre pressure check
- Installation of mirrors and any accessories
- Battery installation



NEVER EXCEED THE RECOMMENDED INFLATION PRESSURES SINCE THE TYRES MAY BURST.

CAUTION



CHECK AND ADJUST TYRE PRESSURE WITH TYRES AT AMBIENT TEMPERATURE.

CAUTION



Do not leave the vehicle with the engine off and the ignition key to "ON". The sophisticated on-board instruments have a high current draw which, if left on with the engine switched off, will discharge the battery in a short time.

Specific operations for the vehicle

UNPACKING

CAUTION



THE UNPACKING OF THE VEHICLE REQUIRES THE INTERVENTION OF 2 OPERATORS AND MUST NOT BE CARRIED OUT BY A SINGLE OPERATOR. ALWAYS USE PERSONAL PROTECTIVE EQUIPMENT WHEN WORKING.

- Position the packing on a flat surface and check its integrity.



- Cut the plastic strapping of the packaging using a cutter.



- Grasp the cardboard cover by the openings on the short sides of the packaging and lift it off the wooden platform.



CAUTION



LIFT THE CARDBOARD COVER VERTICALLY, DO NOT ROTATE OR TILT IT AND TAKE EXTRA CARE NOT TO DAMAGE THE VEHICLE WHEN LIFTING IT.



- Store the cardboard cover away from the vehicle.
- Check the integrity of the footrest and ensure that the vehicle is free from dents and/or scratches.



- Remove the boxes of the components supplied (mirrors and battery) from the footrest.



- Support the vehicle while the second operator removes the retaining straps, starting with the rear straps.



- Then remove the front retaining straps.

CAUTION

DO NOT REMOVE THE VEHICLE FROM THE WOODEN PLATFORM AT THIS TIME.



- Using suitable tools, remove the front cross member of the wooden platform.



- Making sure that the platform remains stationary, lower the vehicle from the front of the wooden platform, supporting it by the handlebar and the rear handles.



- Place the vehicle on the side stand and remove the windscreen protection bag.



- Remove the protective bags of the two cylinders.
- Install the battery according to the operations described in the section "Body - Battery".
- Install the rear-view mirrors.



FITTING THE REAR-VIEW MIRRORS

- Screw the mirror into the clutch master cylinder (left) or front brake master cylinder (right) support.
- Tighten the nut (1) to the prescribed torque.



Locking torques (N*m)

Rear view mirror fastener nut $4 \pm 0.5 \text{ Nm}$ ($2.95 \pm 0.37 \text{ lb ft}$)

- Position the mirror rod in line with the relative knob.
- Tighten the lock nut (2) to the prescribed torque.
- Position the protective rubber (3) on the mirror fixing.

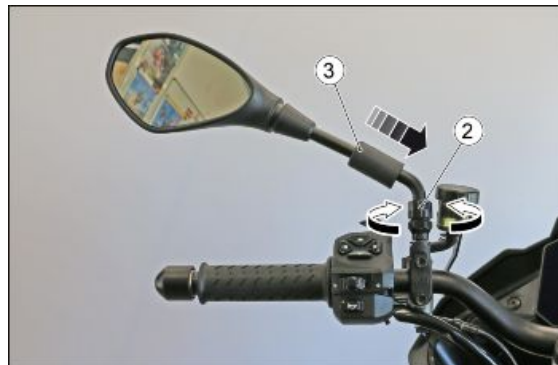

Locking torques (N*m)

Rear-view mirror lock nut $4 \pm 0.5 \text{ Nm}$ ($2.95 \pm 0.37 \text{ lb ft}$)

INDEX OF TOPICS

CHARACTERISTICS

CHAR

Rules

Safety rules

Carbon monoxide

If you need to keep the engine running while working on the vehicle, please ensure that you do so in an open or very well ventilated area. Never run the engine in an enclosed area. If you do work in an enclosed area, make sure to use a fume extraction system.

CAUTION



EXHAUST EMISSIONS CONTAIN CARBON MONOXIDE, A POISONOUS GAS WHICH CAN CAUSE LOSS OF CONSCIOUSNESS AND EVEN DEATH.

Fuel

CAUTION



FUEL USED TO DRIVE EXPLOSION ENGINES IS HIGHLY INFLAMMABLE AND CAN BECOME EXPLOSIVE UNDER SPECIFIC CONDITIONS. IT IS THEREFORE RECOMMENDED TO CARRY OUT REFUELLING AND MAINTENANCE PROCEDURES IN A VENTILATED AREA WITH THE ENGINE SWITCHED OFF. DO NOT SMOKE DURING REFUELLING OR NEAR FUEL VAPOUR. AVOID ANY CONTACT WITH NAKED FLAME, SPARKS OR OTHER HEAT SOURCES WHICH MAY CAUSE IGNITION OR EXPLOSION.

**DO NOT ALLOW FUEL TO DISPERSE INTO THE ENVIRONMENT.
KEEP OUT OF THE REACH OF CHILDREN.**

Hot parts

The engine and the exhaust system components get very hot and remain in this condition for a certain time interval after the engine has been switched off. Before handling these components, make sure that you are wearing insulating gloves or wait until the engine and the exhaust system have cooled down.

Coolant

The coolant contains ethylene glycol which, under certain conditions, can become flammable.

When it burns, ethylene glycol produces an invisible flame which however can cause burns.

CAUTION



TAKE PARTICULAR CARE NOT TO SPILL COOLANT ONTO HOT PARTS OR THE ENGINE AND EXHAUST SYSTEM; THE FLUID MAY IGNITE AND BURN WITH AN INVISIBLE FLAME. WHEN CARRYING OUT MAINTENANCE, IT IS ADVISABLE TO WEAR LATEX GLOVES. WHILE POISONOUS, COOLANT HAS A SWEET TASTE WHICH MAKES IT EXTREMELY APPEALING TO ANIMALS. NEVER LEAVE COOLANT IN OPEN CONTAINERS WHERE IT MAY BE REACHED AND DRUNK BY AN ANIMAL.

**KEEP OUT OF THE REACH OF CHILDREN.
NEVER REMOVE THE RADIATOR CAP WHILE THE ENGINE IS STILL HOT. COOLANT IS UNDER PRESSURE AND MAY CAUSE BURNS.**

Used engine oil and transmission oil

CAUTION



WHEN CARRYING OUT MAINTENANCE OPERATIONS, IT IS ADVISABLE TO WEAR PROTECTIVE IMPERMEABLE GLOVES.

THE ENGINE OR GEARBOX OIL MAY CAUSE SERIOUS INJURIES TO THE SKIN IF HANDLED FOR PROLONGED PERIODS OF TIME AND ON A REGULAR BASIS.

WASH YOUR HANDS CAREFULLY AFTER HANDLING OIL.

HAND THE OIL OVER TO OR HAVE IT COLLECTED BY THE NEAREST USED OIL RECYCLING COMPANY OR THE SUPPLIER.

DO NOT DISPOSE OF OIL IN THE ENVIRONMENT

KEEP OUT OF THE REACH OF CHILDREN.



BRAKE FLUID CAN DAMAGE PAINT FINISH, PLASTIC AND RUBBER. WHEN SERVICING THE BRAKING SYSTEM, PROTECT THESE COMPONENTS WITH A CLEAN CLOTH. ALWAYS WEAR PROTECTIVE EYEWEAR WHEN WORKING ON THE BRAKE SYSTEM. BRAKE FLUID IS EXTREMELY HARMFUL FOR THE EYES. IN THE EVENT OF ACCIDENTAL CONTACT WITH THE EYES, RINSE THE EYES IMMEDIATELY WITH PLENTY OF COOL, CLEAN WATER AND SEEK IMMEDIATE MEDICAL ATTENTION.

KEEP OUT OF THE REACH OF CHILDREN.

Battery electrolyte and hydrogen gas (WHERE REQUIRED)

CAUTION



THE BATTERY ELECTROLYTE IS TOXIC, CORROSIVE AND, AS IT CONTAINS SULPHURIC ACID, MAY CAUSE BURNING IF IT COMES INTO CONTACT WITH THE SKIN. WHEN HANDLING BATTERY ELECTROLYTE, WEAR TIGHT-FITTING GLOVES AND PROTECTIVE APPAREL. IN THE EVENT OF SKIN CONTACT WITH THE ELECTROLYTIC FLUID, RINSE WELL WITH PLENTY OF CLEAN WATER. IT IS PARTICULARLY IMPORTANT TO PROTECT YOUR EYES BECAUSE EVEN TINY AMOUNTS OF BATTERY ACID MAY CAUSE BLINDNESS. IN THE EVENT OF CONTACT WITH THE EYES, RINSE WITH PLENTY OF WATER FOR FIFTEEN MINUTES AND CONSULT AN EYE SPECIALIST IMMEDIATELY. THE BATTERY RELEASES EXPLOSIVE GASES; KEEP IT AWAY FROM FLAMES, SPARKS, CIGARETTES OR ANY OTHER HEAT SOURCES. ENSURE ADEQUATE VENTILATION WHEN SERVICING OR RECHARGING THE BATTERY.

KEEP OUT OF THE REACH OF CHILDREN.

BATTERY LIQUID IS CORROSIVE. DO NOT POUR OR SPILL ON PLASTIC COMPONENTS IN PARTICULAR. ENSURE THAT THE ELECTROLYTIC ACID IS COMPATIBLE WITH THE BATTERY BEING ACTIVATED.

Maintenance rules

GENERAL PRECAUTIONS AND INFORMATION

When repairs, disassembly and reassembly of the vehicle is carried out, follow the following recommendations strictly.

BEFORE DISASSEMBLING COMPONENTS

- Remove the dirt, mud, dust and foreign objects from the vehicle before disassembling components. Wherever required, use the special tools designed for this vehicle.

DISASSEMBLING COMPONENTS

- Do not loosen and/or tighten the screws and nuts using pliers or other tools, but always use the specific wrench.
- Mark the positions on all the connection joints (hoses, cables, etc.) before separating them and identify them with different distinctive marks.
- Each piece should be clearly marked in order to be identified during the installation phase.
- Carefully clean and wash the disassembled components with detergents with a low flammability grade.
- Keep the coupled parts together because they have "adapted" to one another following normal wear.
- Some components must be used together or replaced entirely.
- Keep away from heat sources.

REASSEMBLING THE COMPONENTS

CAUTION

THE BEARING MUST ROTATE FREELY, WITHOUT JAMMING AND/OR NOISE, OTHERWISE THEY MUST BE REPLACED.

- Only use ORIGINAL Moto Guzzi SPARE PARTS.
- Always use the recommended lubricants and consumable material.
- Lubricate the parts (when possible) before reassembling them.
- When tightening screws and nuts, begin with the larger diameter or internal ones, proceeding diagonally. Tighten with subsequent steps before applying the prescribed torque.
- Always replace the locknuts, gaskets, seal rings, snap rings, O-Rings (OR), cotter pins and screws if they have damaged thread, with new ones.
- When disassembling the bearings, lubricate them abundantly.
- Ensure that each component has been assembled correctly.
- After a repair or periodic maintenance operation, carry out the preliminary checks and test the vehicle on private property or in an area with light traffic.
- Clean all coupling surfaces, oil seal rims and gaskets before refitting them. Smear a light layer of lithium-based grease on the oil seal rims. Reassemble oil seals and bearings with the brand or lot number facing outward (visible side).

ELECTRICAL CONNECTORS

The electrical connectors should be disconnected as follows. Failure to observe these procedures will cause irreparable damage to the connector and the wiring:

If present, press on the specific safety catches.

- Grip the two connectors and unplug them, pulling them apart in opposite directions.

- If there is dirt, rust, moisture, etc., carefully clean the inside of the connector using pressurised air.
- Ensure that the cables make correct contact with the terminals inside the connectors.
- Then plug in the two connectors, ensuring correct coupling (if the specific catches are present, you will hear a typical "click").

CAUTION

TO UNPLUG THE TWO CONNECTORS, DO NOT PULL ON THE CABLES.

NOTE

THE TWO CONNECTORS CAN BE PLUGGED IN ONLY IN ONE DIRECTION, THEREFORE JOIN THEM TOGETHER IN THE RIGHT DIRECTION.

TIGHTENING TORQUES**CAUTION**

REMEMBER THAT THE TIGHTENING TORQUE FOR ALL THE FIXING ELEMENTS LOCATED ON WHEELS, BRAKES, WHEEL AXLES AND OTHER SUSPENSION COMPONENTS PLAY A FUNDAMENTAL ROLE IN GUARANTEEING THE SAFETY OF THE VEHICLE AND MUST BE KEPT AT THE PRESCRIBED VALUES. REGULARLY CHECK THE TIGHTENING TORQUE OF THE FIXING ELEMENTS AND ALWAYS USE A TORQUE WRENCH WHEN REFITTING. IF THESE WARNINGS ARE NOT OBSERVED, ONE OF THESE COMPONENTS COULD LOOSEN AND COME OFF, BLOCKING A WHEEL OR CAUSING OTHER PROBLEMS THAT WOULD COMPROMISE MANOEUVRABILITY, LEADING TO A CRASH WITH THE RISK OF SERIOUS INJURY OR EVEN DEATH.

Running-in

Running in is essential to ensure the durability of the vehicle. During the first 1500 Km (932 mi), observe the following rules to ensure the reliability and performance of the vehicle throughout its lifetime:

- Avoid full throttle starts and hard acceleration;
- Avoid exceeding 4,500 rpm;
- Avoid hard or prolonged braking;
- Do not ride for prolonged periods at sustained high speed; preferably ride the motorcycle on varied routes with frequent, gentle acceleration and deceleration;
- Ride prudently to gradually gain familiarity with the motorcycle, testing progressively higher throttle apertures only as you gain confidence

CAUTION

THE FULL PERFORMANCE OF THE VEHICLE IS ONLY AVAILABLE AFTER THE SERVICE AT THE END OF THE RUNNING IN PERIOD.

Follow these guidelines:

- Do not twist the throttle grip abruptly and completely when the engine is working at a low revs, either during or after run-in.
- During the first 100 Km (62 miles) use the brakes gently, avoiding sudden or prolonged braking. That is to permit the adequate adjustment of the pad friction material to the brake discs.



AFTER THE SPECIFIED MILEAGE, TAKE THE VEHICLE TO AN OFFICIAL Moto Guzzi DEALER FOR THE CHECKS INDICATED IN THE "AFTER RUN-IN" TABLE IN THE SCHEDULED MAINTENANCE SECTION TO AVOID INJURING YOURSELF, OTHERS AND /OR DAMAGING THE VEHICLE.

Vehicle identification

SERIAL NUMBER LOCATION

These numbers are necessary for vehicle registration.

NOTE

ALTERING IDENTIFICATION NUMBERS MAY BE SERIOUSLY PUNISHABLE BY LAW. IN PARTICULAR, MODIFYING THE CHASSIS NUMBER IMMEDIATELY VOIDS THE WARRANTY.

FRAME NUMBER

The chassis number is stamped on the RH side of the headstock.

This number consists of numbers and letters, as in the example shown below.

ZGUMGA00XNMXXXXXX

KEY:

ZGU: WMI (World Manufacturer Identifier) code;

MG: vehicle type;

A00: variant and version (A00: V100 Mandello - B00: V100 Mandello S);

X: check digit

N: year of manufacture, variable (N - for 2022)

M: production plant (M= Mandello del Lario);

XXXXXX: serial number of the frame (6 digits);



ENGINE NUMBER

The engine number is stamped on the left side of the crankcase, under the cylinder.



Dimensions and mass

DIMENSIONS AND MASS

Specification	Desc./Quantity
Maximum Length	2125 mm (83.66 in)

Specification	Desc./Quantity
Maximum width	835 mm (32.87 in)
Height (adjustable at the windshield)	1210 - 1300 mm (47.63 - 51.18 in)
Wheelbase	1475 mm (58.07 in)
Kerb weight	233 kg (513.68 lb)

Engine

ENGINE

Specification	Desc./Quantity
Type	Four-stroke, 90° transverse V-twin
Number of cylinders	2
Engine capacity	1042 cc (63.59 cu in)
Bore / stroke	96 x 72 mm (3.77 x 2.83 in)
Compression ratio	12.6 ± 0.5 : 1
Ignition	Electric
Idle engine speed	1400 +/- 100 rpm
Clutch	Multi plate wet clutch with anti-judder function.
Lubrication system	pressure-fed, controlled by valves and trochoidal pump
Air filter	cartridge-type dry filter
Cooling	Forced coolant circulation system.

Transmission

TRANSMISSION

Specification	Desc./Quantity
Primary drive	with gears, ratio: 31/48 = 1 : 1,548
Gear ratios, 1st gear	14 / 37 = 1 : 2,642
Gear ratios, 2nd gear	17 / 33 = 1 : 1,941
Gear ratios, 3rd gear	20 / 31 = 1 : 1,55
Gear ratios, 4th gear	22 / 28 = 1 : 1,272
Gear ratios, 5th gear	24 / 26 = 1 : 1,083
Gear ratios, 6th gear	25 / 24 = 1 : 0,96
Final drive	with shaft, ratio 12 / 38 = 1 : 3,166

GEARBOX

Specification	Desc./Quantity
Type	mechanical, 6 speeds with foot lever on the left hand side of the engine

Capacities

CAPACITY

Specification	Desc./Quantity
Fuel tank capacity (including reserve)	17 l (3.74 UK gal; 4.49 US gal)
Fuel tank reserve capacity	3.5 +/- 0.5 l (0.77 +/- 0.11 UK gal; 0.92 +/- 0.13 US gal)
Engine oil	Oil change and oil filter replacement: 4900 cc in (299.02 cu in)
Bevel gear set oil	250 cm ³ (15.26 cu in)
Bevel gear oil (in case of replacement)	225 cc (13.73 cu in) MAX
Seats	2
Max. vehicle load	443 kg (976.64 lb) (rider + passenger + luggage)

Electrical system

ELECTRICAL SYSTEM

Specification	Desc./Quantity
Battery	12 V - 12 Ah
Fuses	40- 30 - 20 - 15 (3) - 10 (2) - 7.5 (6) - 5 (3) - 3 A
Permanent magnet alternator	12V - 550W

BULBS

Specification	Desc./Quantity
High beam/low beam light	LED
Fog lights	LED
Front DRL	LED
Turn signal lights	LED
Rear running light / brake light	LED
Dashboard lighting	LED

INDICATOR LAMPS

Specification	Desc./Quantity
Gearbox in neutral	LED
High beam headlight	LED
Cruise control warning light	LED
ABS warning light	LED
MI warning light	LED
Turn indicators	LED
Overspeed threshold / gear shift warning lights	LED
Immobilizer warning light	LED
Fuel reserve	LED
MGCT warning light	LED
General alarm	LED
Daytime running lights warning light	LED
Side stand warning light	LED

SPARK PLUGS

Specification	Desc./Quantity
Standard	NGK LMAR8EI-7
Spark plug electrode gap	0.8 mm (0.031 in)
Resistance	7.5 KOhm (MAX)

Frame and suspensions

CHASSIS

Specification	Desc./Quantity
Type	high strength tubular steel frame
Steering rake angle	24.7°
Trail	104 mm (4.095 in)

SUSPENSION

Specification	Desc./Quantity
Front (V100 Mandello)	hydraulic telescopic fork, Ø 41 mm (1.61 in)
Rear (V100 Mandello S)	electronically controlled hydraulic telescopic fork, diameter 43 mm (1.69 in)
Travel (V100 Mandello)	130 mm (5.11 in)
Travel (V100 Mandello S)	130 mm (5.11 in)
Rear	Swingarm in die-cast light alloy with 1 shock absorber with adjustable spring pre-loading and hydraulic brake extension.
Travel (V100 Mandello)	130 mm (5.11 in)
Travel (V100 Mandello S)	130 mm (5.11 in)

Brakes

BRAKES

Specification	Desc./Quantity
Front	two 320 mm (12.59 in) diam. stainless steel floating discs, calliper with 4 32 mm (1.26 in) diam. counteracting plungers
Rear	280 mm (11.02 in) stainless steel disc, floating calliper with two 28 mm (1.10 in) diameter pistons

Wheels and tyres

RIMS AND WHEELS

Specification	Desc./Quantity
Type	die-cast alloy
Front	3.5" x 17"
Rear	6.00" x 17"

TYRES

Specification	Desc./Quantity
Front	120 / 70 ZR17 (58W)
Tyre pressure	2.5 bar (250 kPa) (36.26 PSI)
Rear	190 / 55 ZR17 (75W)
Tyre pressure	2.8 bar (280 Kpa) (40.61 PSI)

Supply

FUEL SYSTEM

Specification	Desc./Quantity
Type	Electronic injection (Marelli 11MP)
Throttle body	Ø 52 mm (2.05 in)
Fuel	Unleaded gasoline E10 (95 R.O.N.)

Tightening Torques

Chassis

Front side

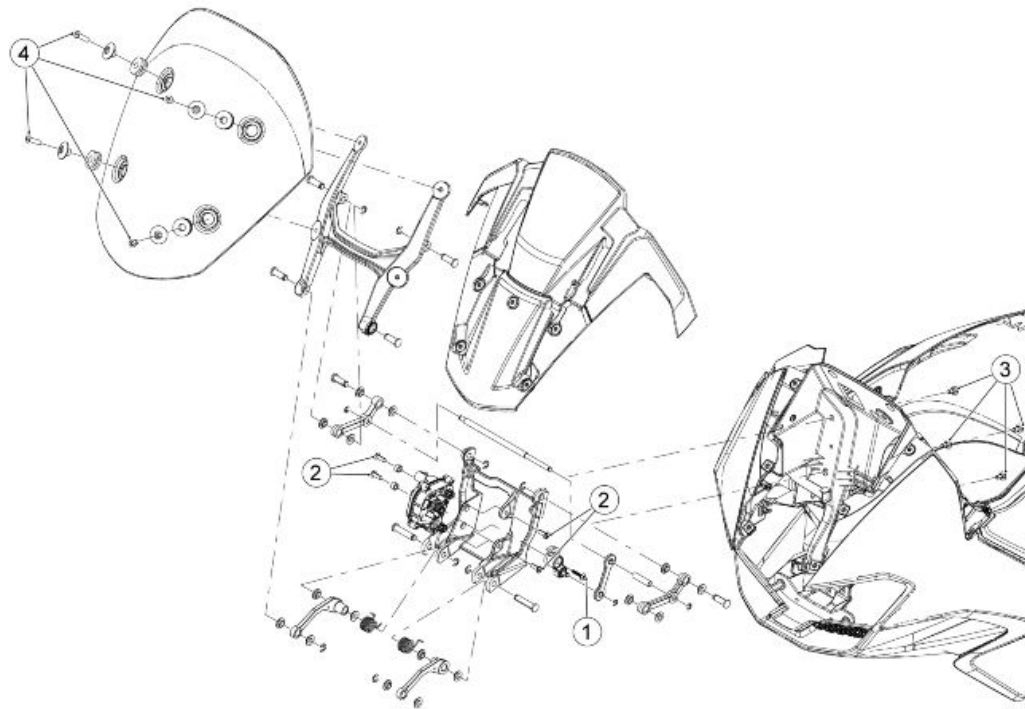
**TOP FAIRING**

Pos.	Description	Type	Quantity	Torque	Notes
1	Fixing screw for actuator connecting rod	SWP 5x30	1	1 ± 0.3 Nm (1.11 ± 0.22 lb ft)	-
2	Fixing screw for actuator	Self-tapping 5.1x18	4	2.5 ± 0.3 Nm (1.84 ± 0.22 lb ft)	-
3	Fixing screw for actuator assembly	M5	4	4 ± 0.8 Nm (2.95 ± 0.59 lb ft)	-
4	Top fairing fastener screw	M6	4	10 ± 2 Nm (7.38 ± 1.48 lb ft)	-

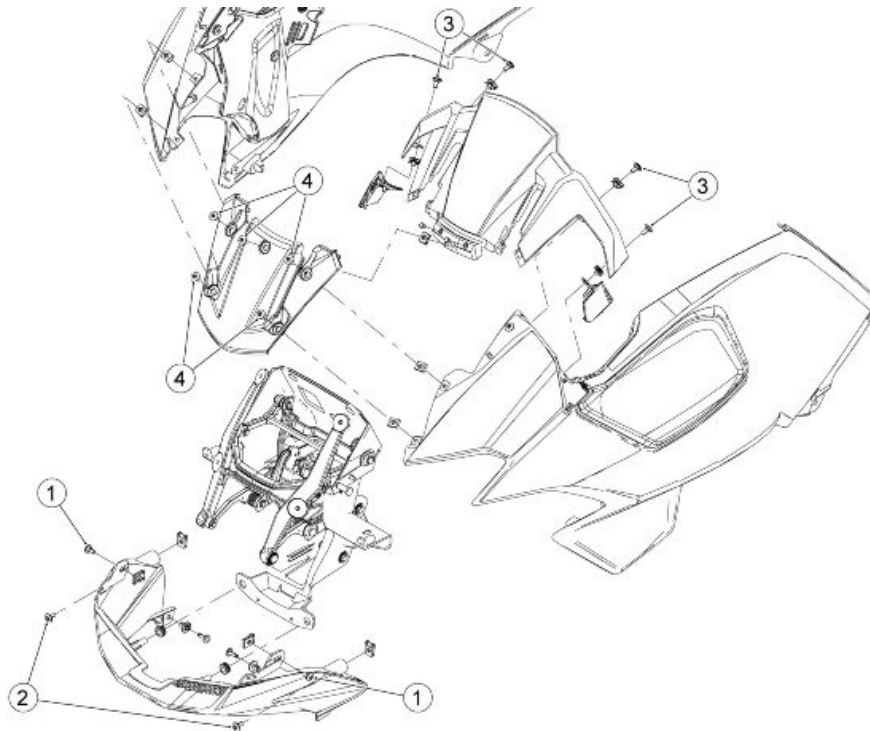

FRONT FAIRING

Pos.	Description	Type	Quantity	Torque	Notes
1	Fixing screw for front spoiler	M5	2	4 ± 0.8 Nm (2.95 ± 0.59 lb ft)	-
2	Fixing screw for side fairing to spoiler	M5	1+1	4 ± 0.8 Nm (2.95 ± 0.59 lb ft)	-
3	Upper front fixing screw	M5	4	4 ± 0.8 Nm (2.95 ± 0.59 lb ft)	-
4	Lower front fixing screw	M5	5	4 ± 0.8 Nm (2.95 ± 0.59 lb ft)	-

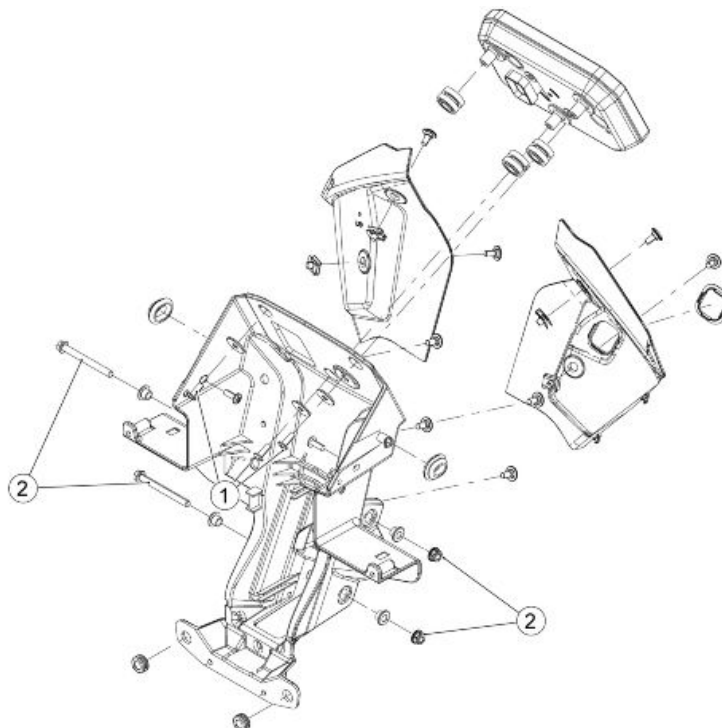

INSTRUMENTS

Pos.	Description	Type	Quantity	Torque	Notes
1	Fixing screw for TFT instrument panel	SWP 4.9	3	3 ± 0.5 Nm (2.21 ± 0.37 lb ft)	-
2	Instrument panel bracket fastening	M6	2	10 ± 2 Nm (7.38 ± 1.48 lb ft)	Screw and nut

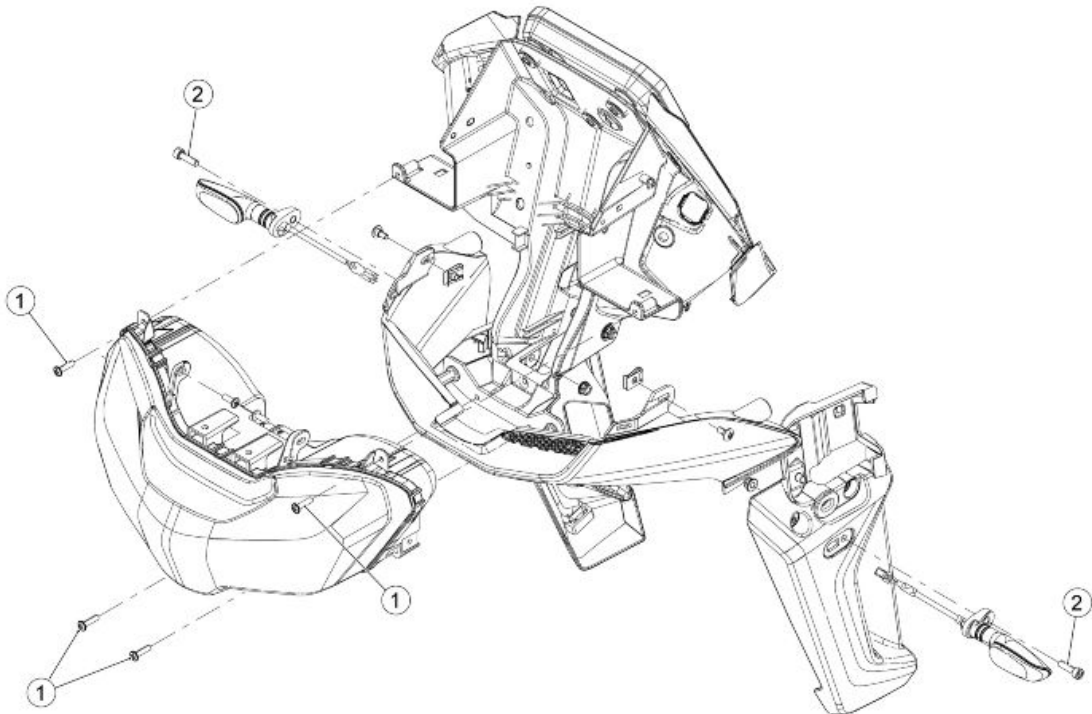

HEADLAMP

Pos.	Description	Type	Quantity	Torque	Notes
2	Fixing screw for lower fork closure	M6	4	10 ± 2 Nm (7.38 ± 1.48 lb ft)	-
2	Turn indicator fastener screw	M6	2	3 ± 0.5 Nm (2.21 ± 0.37 lb ft)	With self-locking nut

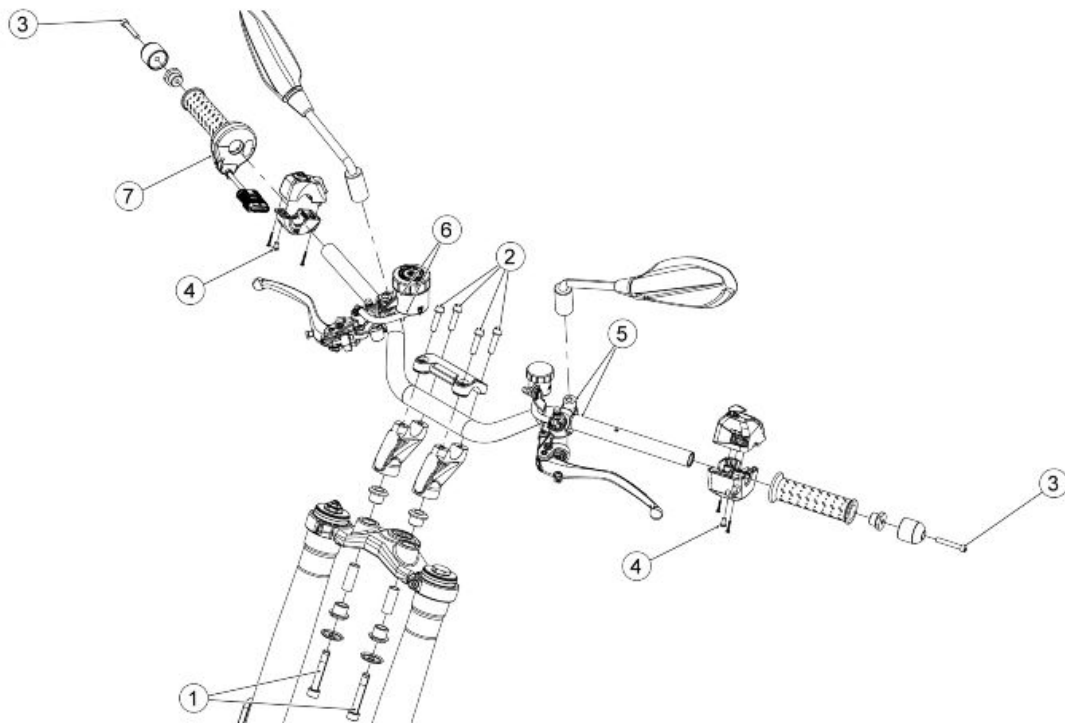

HANDLEBAR-CONTROLS

Pos.	Description	Type	Quantity	Torque	Notes
1	Screws fastening the lower U-bolts to the upper steering yoke	M10	2	50 Nm (36.88 lbf ft)	Loctite 243
2	Screws fastening the lower U-bolt clamp to the handlebar	M8	4	25 Nm (18.44 lbf ft)	-
3	Screws fastening the anti-vibration weights to the handlebar	M6	1+1	10 Nm (7.38 lbf ft)	-
4	Screws fastening the light switch to handlebar	M5	1+1	4 Nm (2.95 lbf ft)	Pre-fitted on the light switch
5	Clutch pump U-bolt fastening screws	M6	2	10 Nm (7.38 lbf ft)	-
6	Front brake master cylinder U-bolt fixing screws	M6	2	10 Nm (7.38 lbf ft)	-
7	Screw fastening the electronic throttle control to handlebar	M4	1	4 Nm (1.62 lbf ft)	Pre-fitted on the throttle control

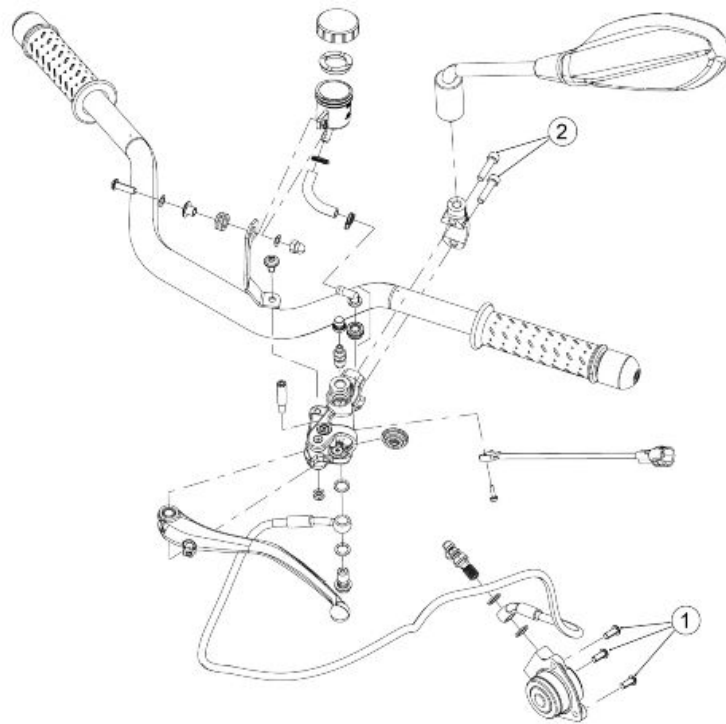

CLUTCH CONTROL

Pos.	Description	Type	Quantity	Torque	Notes
1	Actuator fixing screw to clutch crankcase	M6	3	10 ± 2 Nm (7.38 ± 1.48 lb ft)	-
2	Fixing screw for clutch lever U-bolt	M6	2	10 ± 1.5 Nm (7.38 ± 1.11 lb ft)	-

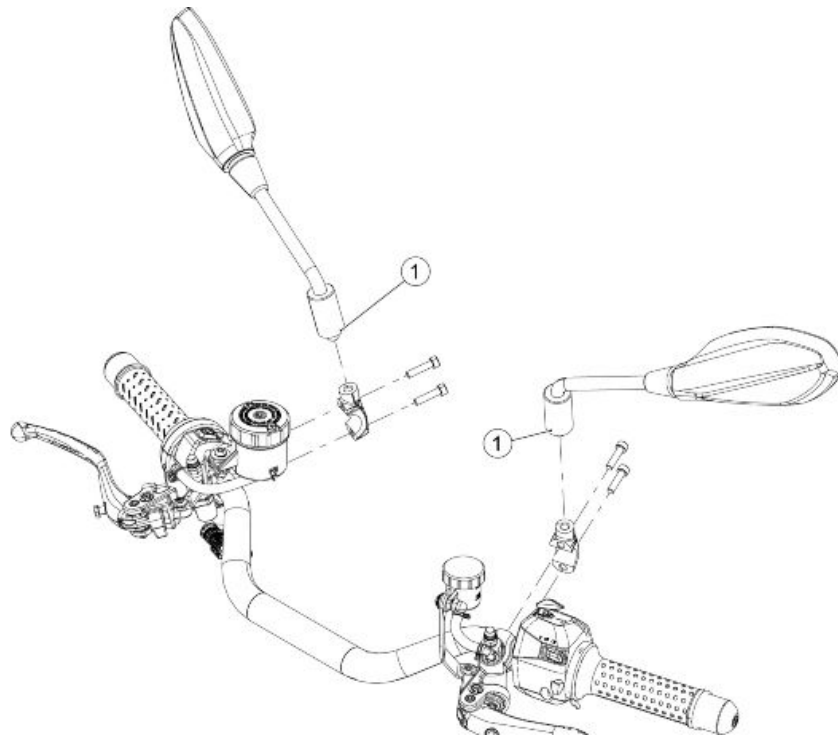

MIRRORS

Pos.	Description	Type	Quantity	Torque	Notes
1	Fixing nut for mirror bracket	M6	2+2	4 ± 0.5 Nm (2.95 ± 0.37 lbf ft)	-

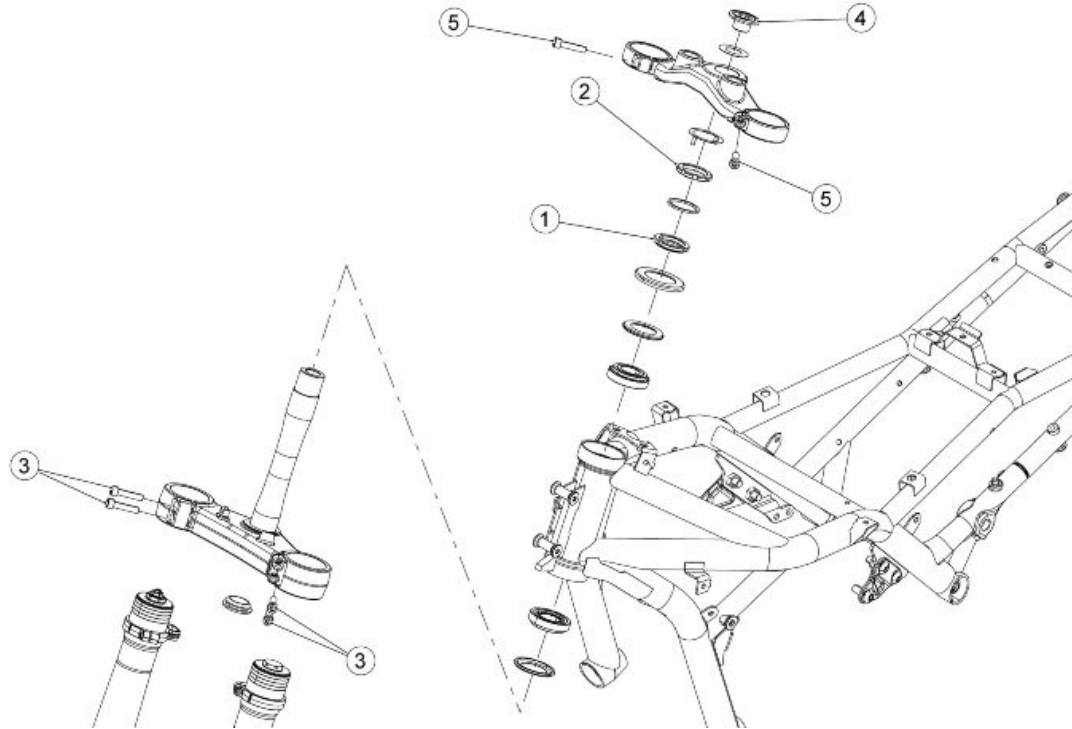

STEERING

Pos.	Description	Type	Quantity	Torque	Notes
1	Ring nut fastening the bottom yoke/steering pin assembly to the headstock	-	1	-	First tightening torque 60 Nm (44.25 lbf ft) - Second tightening torque 30 Nm +/- 5 Nm (22.13 +/- 3.69 lbf ft)
2	Counter-lock ring fastening the bottom yoke/steering pin assembly to the headstock	-	1	-	Manual
3	Screw fastening the fork stanchions to the lower steering yoke	M8	4	25 Nm (18.44 lbf ft)	-
4	Top steering yoke fastener bush	-	1	100 Nm (73.76 lbf ft)	-
5	Screw fastening the fork stanchions to the upper steering yoke	M8	2	25 Nm (18.44 lbf ft)	-

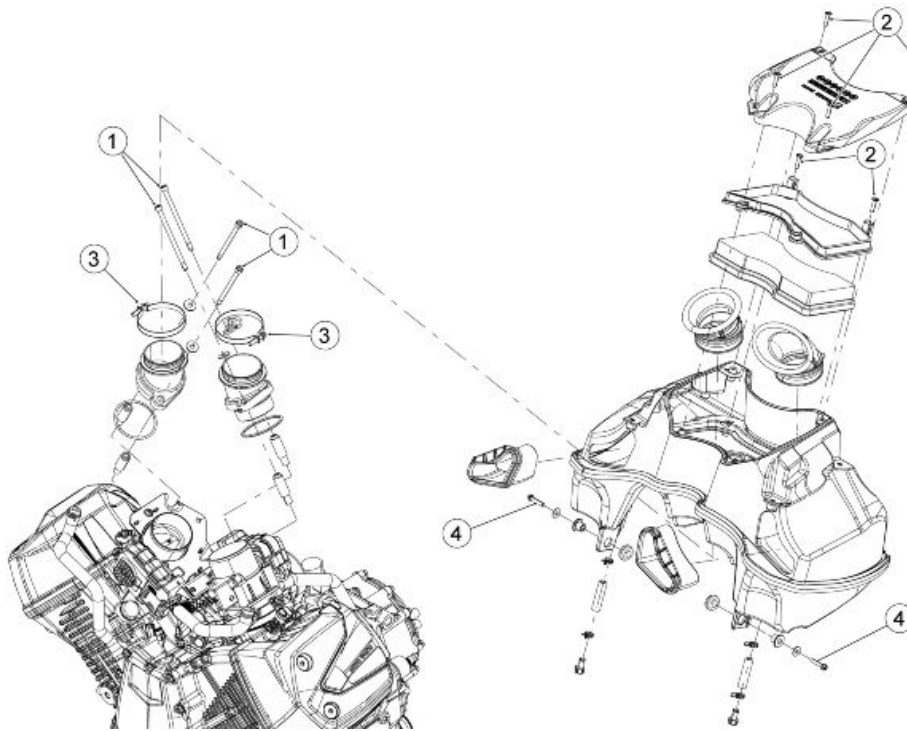

INTAKE ASSEMBLY

Pos.	Description	Type	Quantity	Torque	Notes
1	Fixing screw for intake ducts to throttle bodies	M6	4	10 ± 1.5 Nm (7.38 ± 1.11 lb ft)	-
2	Fixing screws for air filter and filter case cover	SWP 4.9	6	3 ± 0.5 Nm (2.21 ± 0.37 lbf ft)	-
3	Intake duct fastening to filter case	Pipe clamp	2	25 ± 5 Nm (18.44 ± 3.69 lb ft)	-
4	Filter casing/frame fastening screw	M5	2	6 ± 1 Nm (4.23 ± 0.74 lb ft)	-

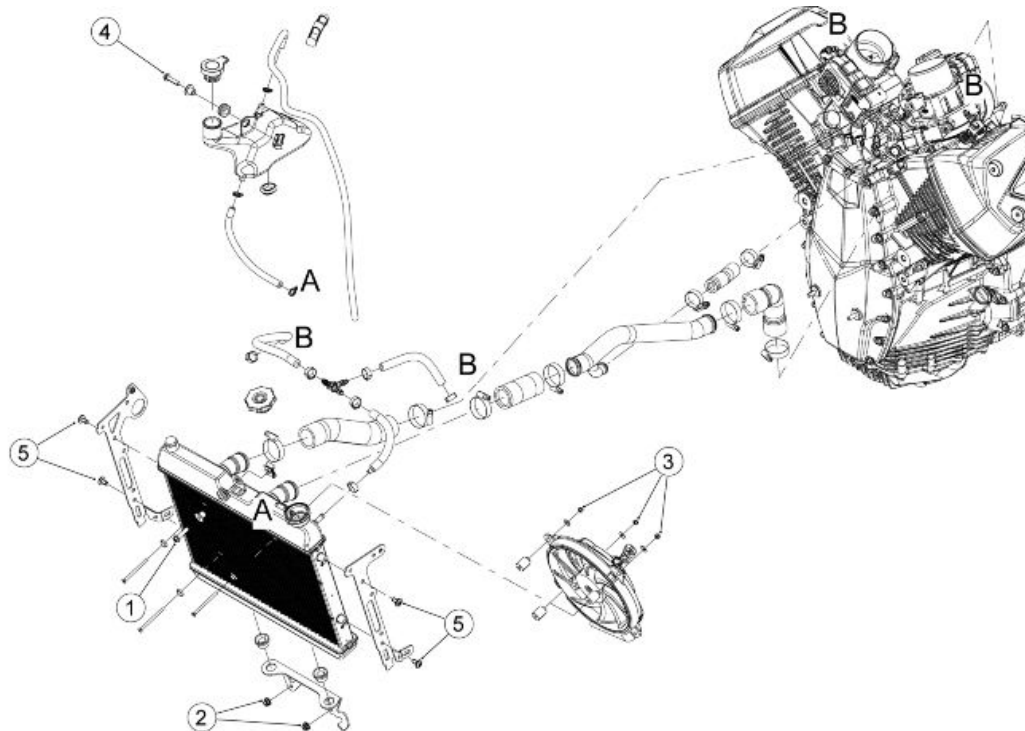

COOLING SYSTEM

Pos.	Description	Type	Quantity	Torque	Notes
1	Upper radiator fixing screw	M6	1	7 ± 1.5 Nm (5.16 ± 1.10 lb ft)	-
2	Lower radiator fixing nut	M6	2	7 ± 1.5 Nm (5.16 ± 1.10 lb ft)	-
3	Fixing nut for electrical fan to radiator	M4	3	0.5 ± 0.1 Nm (0.37 ± 0.074 lb ft)	-
4	Screw for fastening the expansion tank	M6	1	5 ± 0.75 Nm (3.69 ± 0.37 lb ft)	-
5	Side radiator fixing screw	M6	4	10 ± 2 Nm (7.38 ± 1.48 lb ft)	-

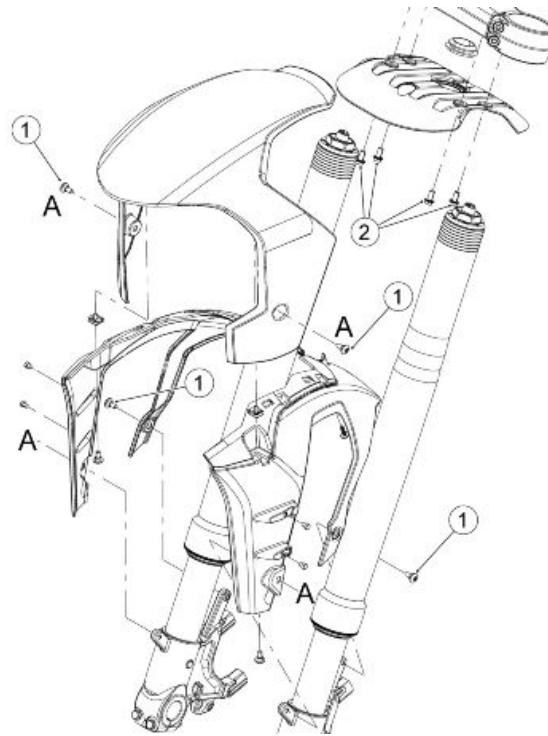

FRONT MUDGUARD

Pos.	Description	Type	Quantity	Torque	Notes
1	Front mudguard fixing screw	M5	4	5.5 ± 1 Nm (4.06 ± 0.78 lbf ft)	-
2	Fixing screw for lower fork closure	M6	4	10 ± 2 Nm (7.38 ± 1.48 lb ft)	-

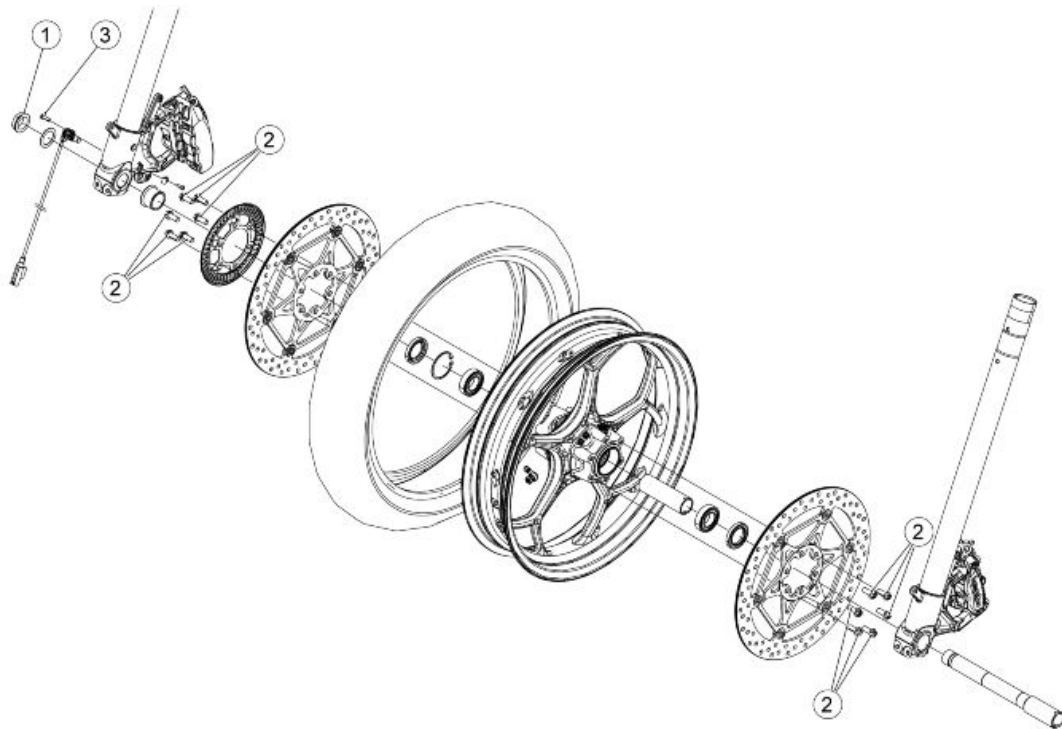

FRONT WHEEL

Pos.	Description	Type	Quantity	Torque	Notes
1	Nut fastening the front wheel axle	M25x1.5	1	80 Nm (59.01 lbf ft)	
2	Brake disc fixing screw	M6	6 + 6	30 Nm (22.13 lbf ft)	Loctite 243
3	ABS sensor fixing screw	M5	1	6 Nm (4.46 lbf ft)	-

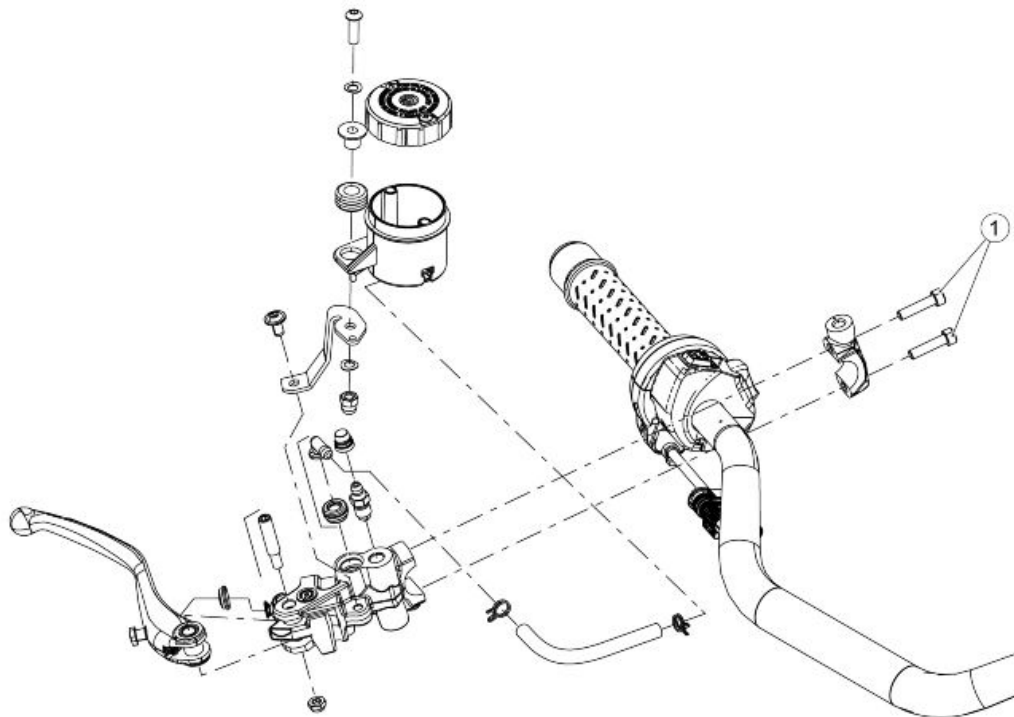

FRONT BRAKE MASTER CYLINDER

Pos.	Description	Type	Quantity	Torque	Notes
1	Screws fixing brake pump clamp to the handlebar	M6	2	10 ± 1.5 Nm (7.38 ± 1.11 lb ft)	-

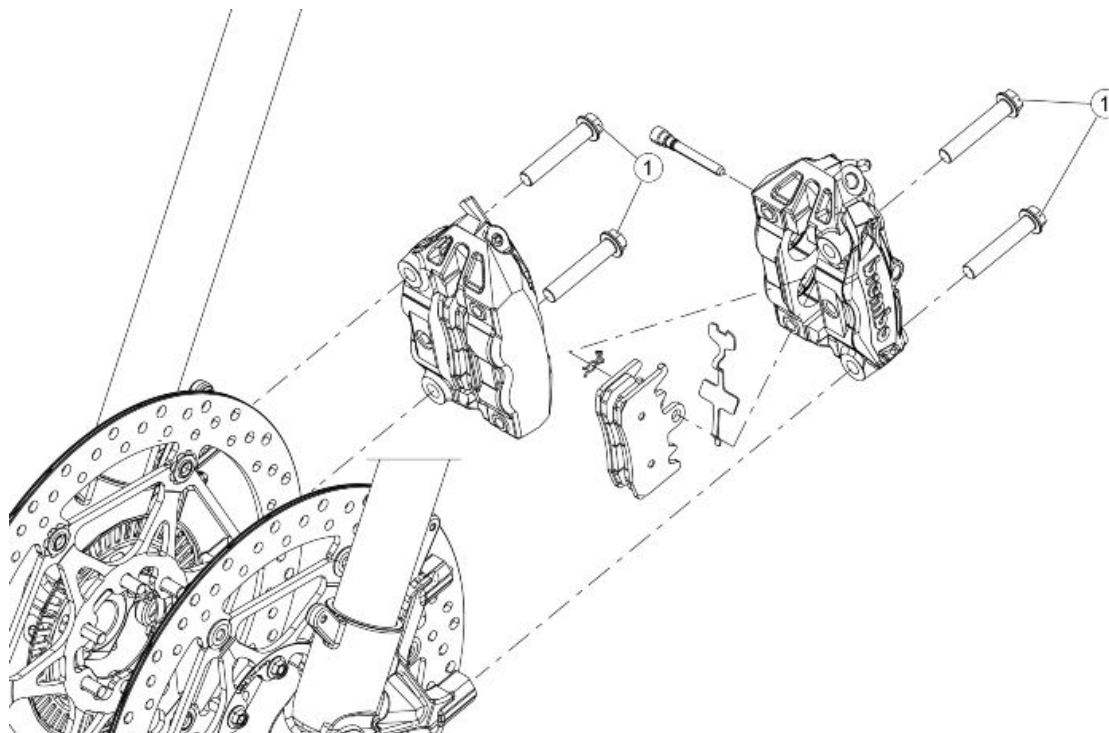

FRONT BRAKE CALLIPER

Pos.	Description	Type	Quantity	Torque	Notes
1	Screws fastening front brake calliper	M10x1.25	2+2	50 ± 5 Nm (36.88 ± 3.69 lb ft)	-

Central part

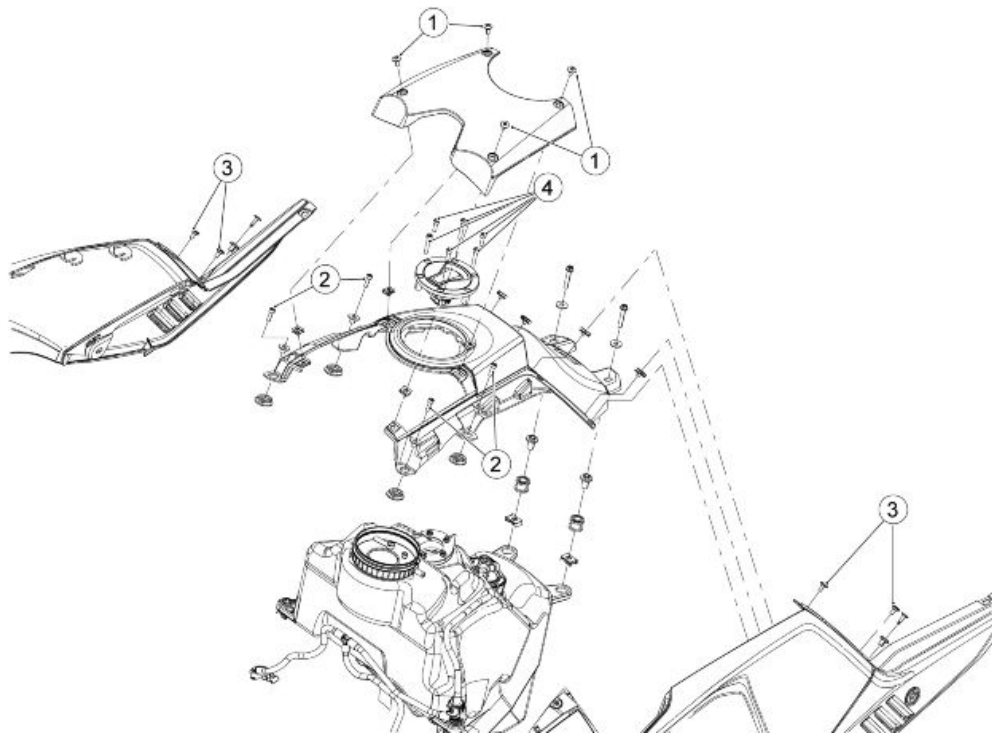
**FUEL TANK COVER**

Pos.	Description	Type	Quantity	Torque	Notes
1	Screw for filter case cover	M5	4	4 ± 0.8 Nm (2.95 ± 0.59 lb ft)	-
2	Fixing screw for tank cover	M5	4	4 ± 0.8 Nm (2.95 ± 0.59 lb ft)	-
3	Fixing screw for side fairing to tank cover	M5	2+2	4 ± 0.8 Nm (2.95 ± 0.59 lb ft)	-
4	Tank plug fixing screw	M5	7	6 ± 1 Nm (4.23 ± 0.74 lb ft)	-

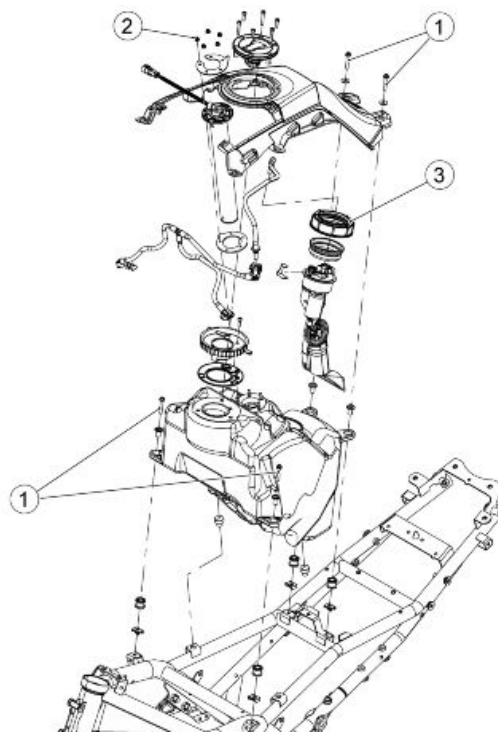

FUEL TANK

Pos.	Description	Type	Quantity	Torque	Notes
1	Screws fastening the fuel tank to frame	M6	4	10 Nm (7.38 lbf ft)	-
2	Ring nut fastening the fuel pump to the fuel tank	-	1	20 Nm (14.75 lbf ft)	-
3	Nuts fixing the fuel level probe to the fuel tank	M4	5	1 Nm (0.74 lb ft)	-

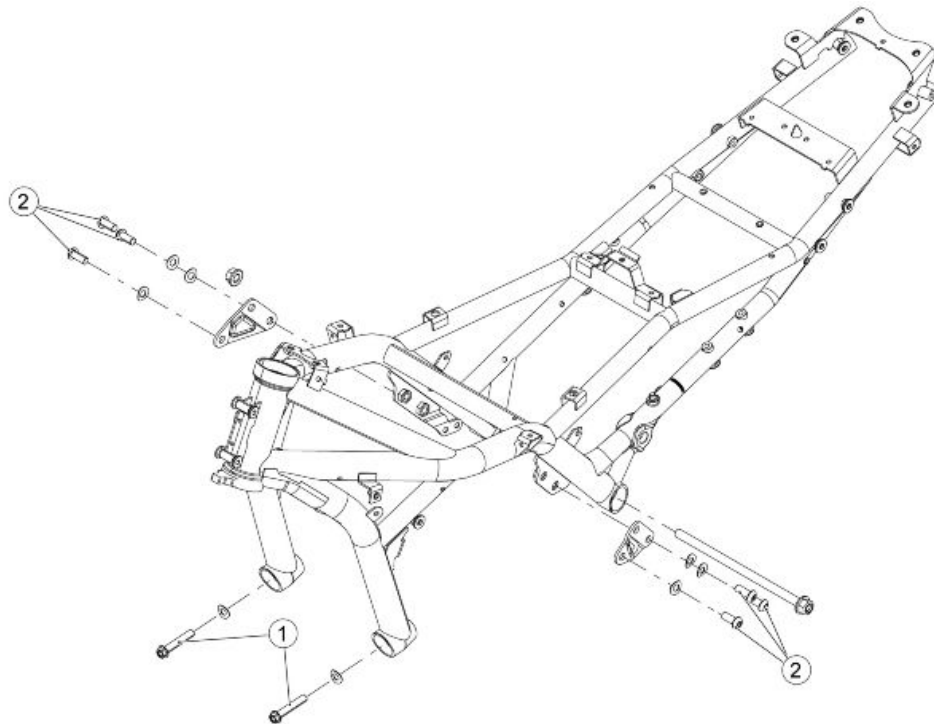

CHASSIS

Pos.	Description	Type	Quantity	Torque	Notes
1	Rear fixing screw for motor to chassis	M10 x 1.25	2	$50 \pm 7.5 \text{ Nm}$ ($36.88 \pm 5.53 \text{ lbf ft}$)	-
2	Side fixing screw for motor to chassis	M10	6	$50 \pm 7.5 \text{ Nm}$ ($36.88 \pm 5.53 \text{ lbf ft}$)	-

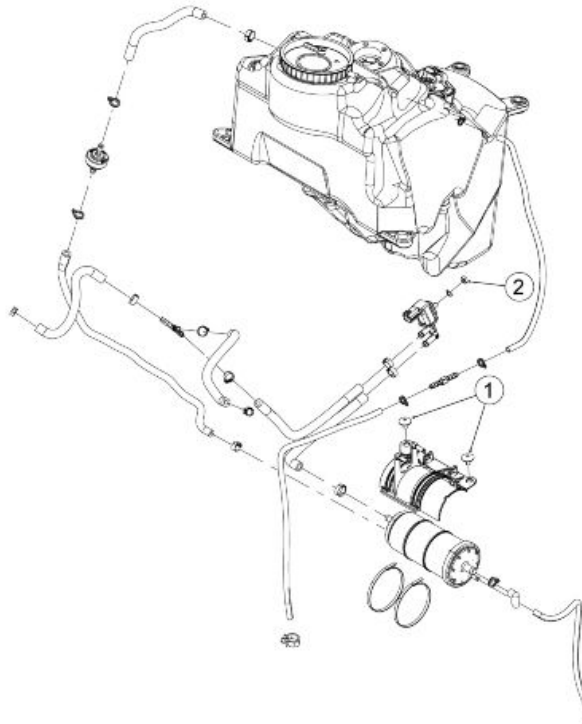
**CANISTER SYSTEM**

Pos.	Description	Type	Quantity	Torque	Notes
1	Fixing screw for canister bracket	M6	2	$10 \pm 2 \text{ Nm}$ ($7.38 \pm 1.48 \text{ lb ft}$)	-
2	Fixing nut for the air solenoid valve	M6	1	$4 \pm 0.8 \text{ Nm}$ ($2.95 \pm 0.59 \text{ lb ft}$)	-

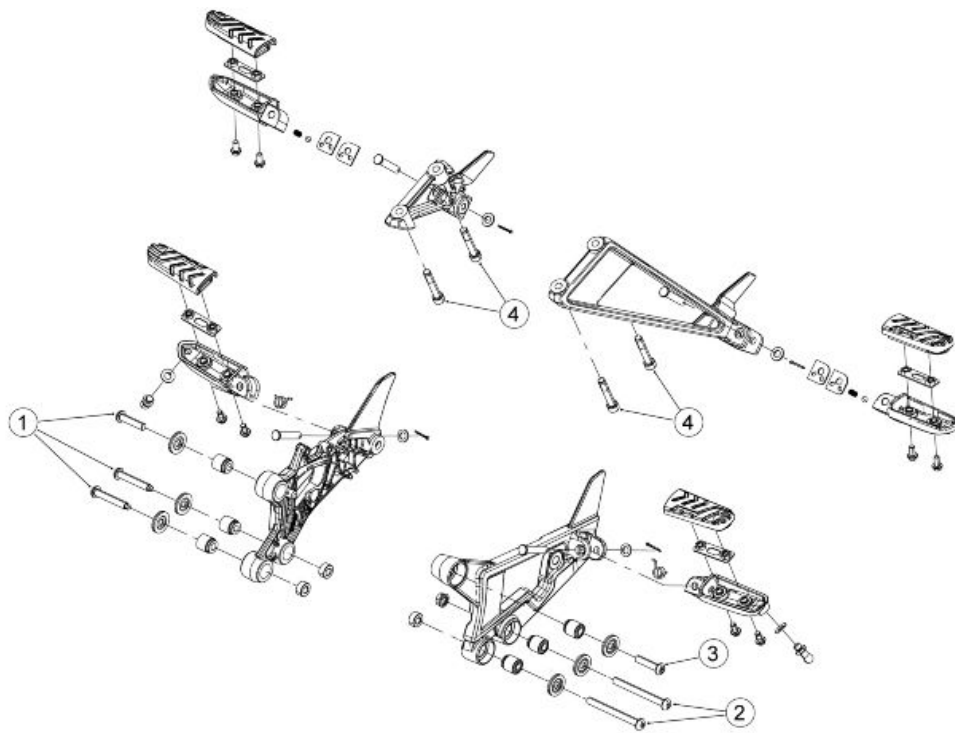

FOOTRESTS

Pos.	Description	Type	Quantity	Torque	Notes
1	Fixing screw for the right footboard	M8	3	25 ± 3.5 Nm (18.44 ± 2.58 lbf ft)	-
2	Fixing screw for the left footboard	M8	2	25 ± 3.5 Nm (18.44 ± 2.58 lbf ft)	-
3	Fixing screw for the left footboard	M8	1	25 ± 3.5 Nm (18.44 ± 2.58 lbf ft)	-
4	Fixing screw for the passenger footrest	M8	2+2	25 ± 3.5 Nm (18.44 ± 2.58 lbf ft)	-

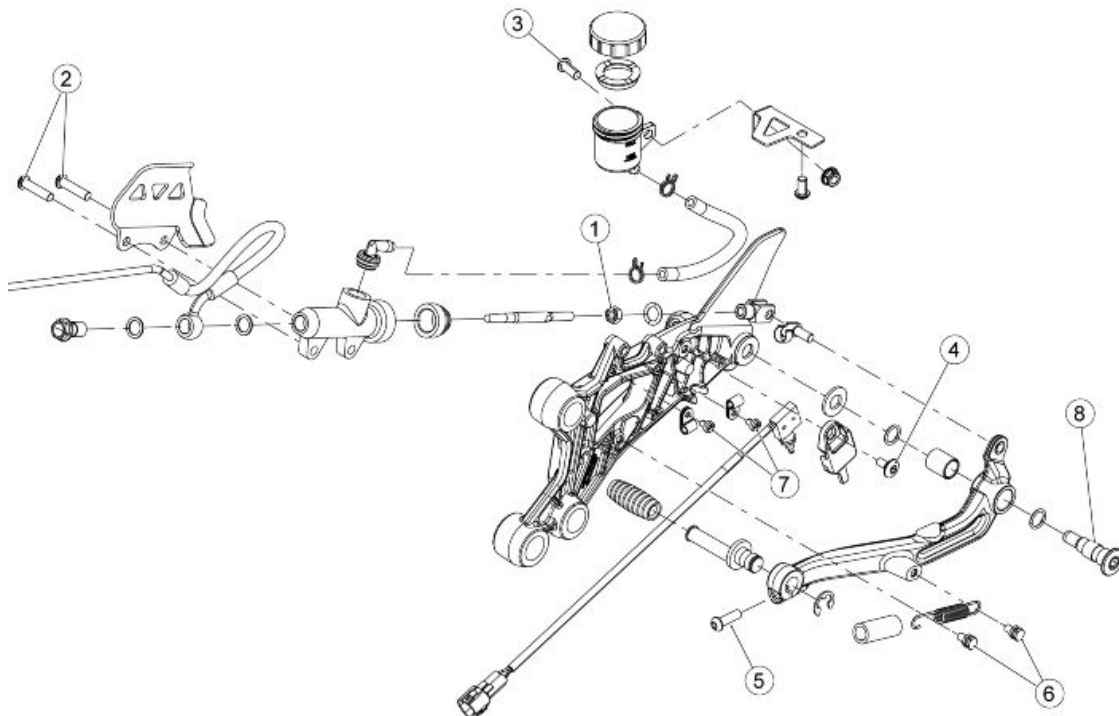

REAR BRAKE MASTER CYLINDER

Pos.	Description	Type	Quantity	Torque	Notes
1	Rear brake rod lock nut	M6	1	6 ± 1 Nm (4.23 ± 0.74 lb ft)	-
2	Rear brake pump fastening screws	M6	2	10 ± 1.5 Nm (7.38 ± 1.11 lb ft)	-
3	Brake oil tank fixing screw	M6	1	6 ± 1 Nm (4.23 ± 0.74 lb ft)	-
4	Brake switch fixing screw	M5	1	6 ± 1 Nm (4.23 ± 0.74 lb ft)	-
5	Rear brake lever rod screw	M6	1	8 ± 1 Nm (5.90 ± 0.74 lbf ft)	-
6	Spring coupling pin for brake lever	M5	2	6 ± 1 Nm (4.43 ± 0.74 lbf ft)	-
7	Brake switch cable gland	M4	2	3 ± 0.5 Nm (2.21 ± 0.37 lbf ft)	-
8	Rear brake lever fixing pin	M8	1	25 ± 3.5 Nm (18.44 ± 2.58 lbf ft)	-

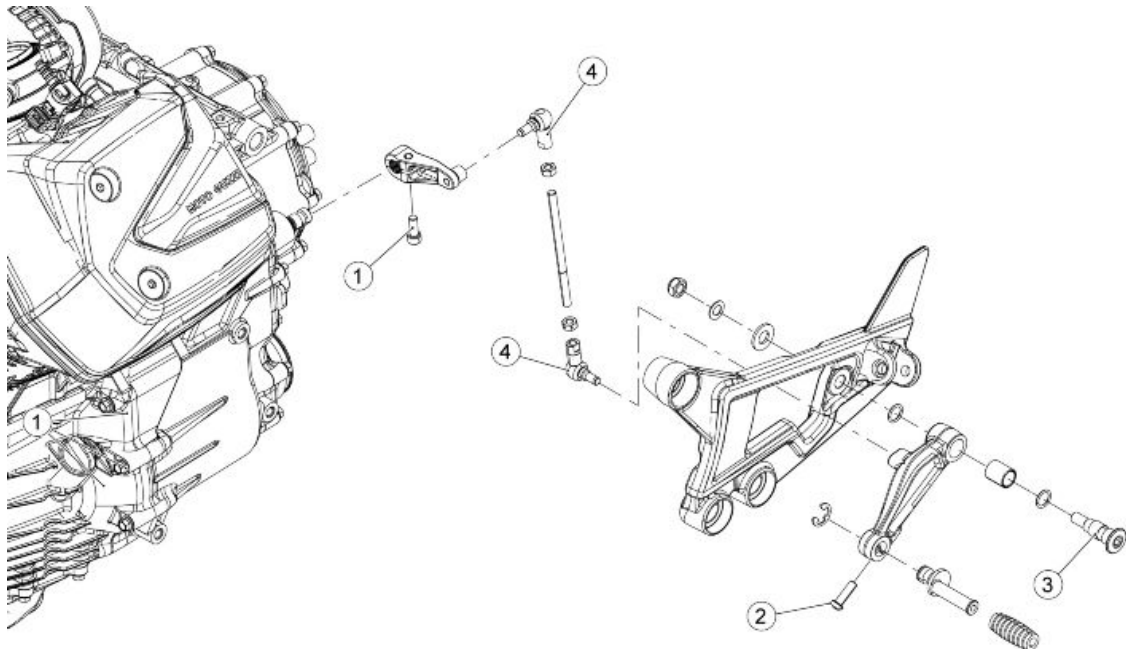
**GEARBOX LEVER**

Pos.	Description	Type	Quantity	Torque	Notes
1	Fixing screw for the gear lever to engine	M6	1	10 ± 1.5 Nm (7.38 ± 1.10 lbf ft)	-
2	Fixing screw for gear shift lever rod	M6	1	8 ± 1 Nm (5.90 ± 0.74 lbf ft)	-
3	Gearbox lever fixing pin	M8	1	25 ± 3.5 Nm (18.44 ± 2.58 lb ft)	-
4	Gear shaft rod fastening	M6	2	8 ± 1 Nm (5.90 ± 0.74 lbf ft)	-

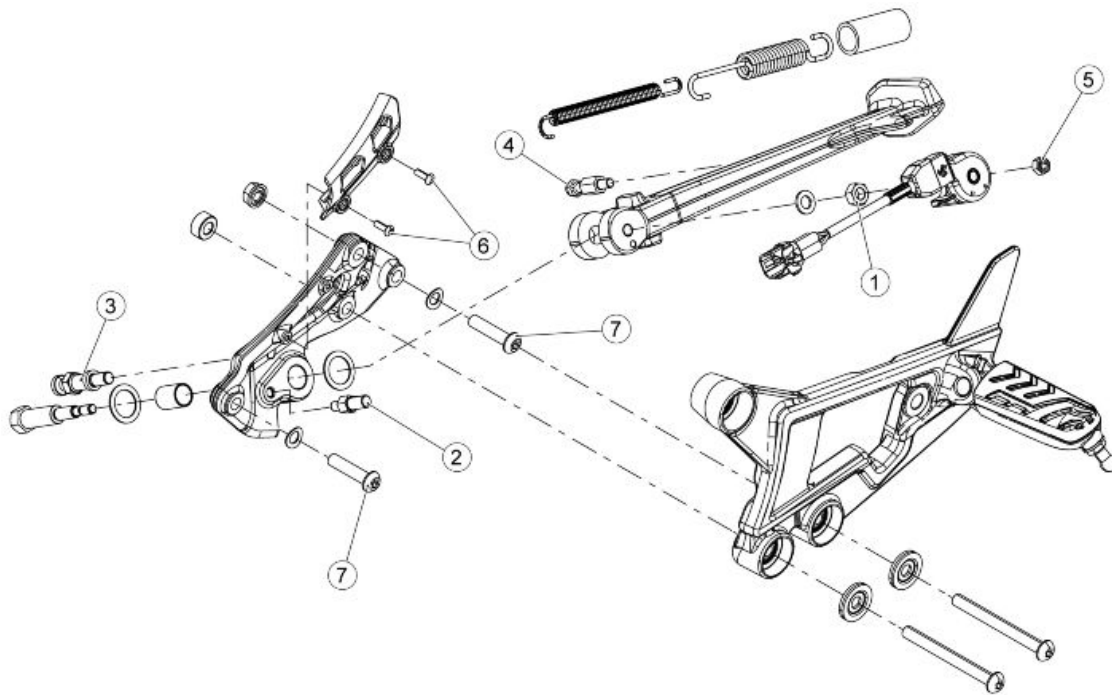

STAND

Pos.	Description	Type	Quantity	Torque	Notes
1	Nut for fastening the stand to the stand plate	M8	1	25 ± 3.5 Nm (18.44 ± 2.58 lb ft)	-
2	Stand switch lock pin	M6	1	10 ± 2 Nm (7.38 ± 1.48 lb ft)	Pre-applied Loct. 243
3	Pin fastening the spring to the stand plate	M8	1	25 ± 5 Nm (18.44 ± 3.69 lb ft)	Pre-applied Loct. 243
4	Pin fastening the spring to the stand	M6	1	10 ± 2 Nm (7.38 ± 1.48 lb ft)	-
5	Stand switch fixing nut	M6	1	10 ± 2 Nm (7.38 ± 1.48 lb ft)	-
6	Stand sensor cable guard fixing screws	M5	2	5.5 ± 1 Nm (4.06 ± 0.74 lb ft)	Pre-applied Loct. 243
7	Screws fastening the stand plate to the engine crankcase	M8	2	25 ± 3.5 Nm (18.44 ± 2.58 lb ft)	-

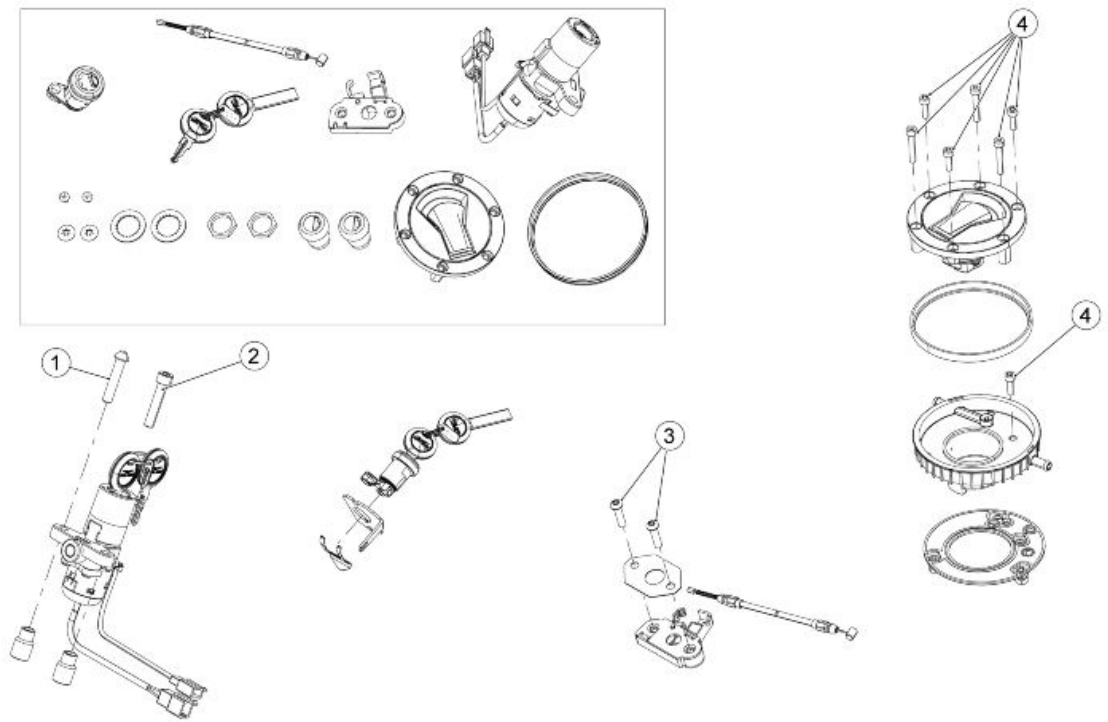

Locks

Pos.	Description	Type	Quantity	Torque	Notes
1	Fixing screw for ignition lock (RH side)	M8	1	Manual	Breaking the screw head
2	Fixing screw for ignition lock (LH side)	M8	1	25 ± 3.5 Nm (18.44 ± 2.58 lb ft)	-
3	Fixing screw for saddle mounting plate	M6	2	10 ± 2 Nm (7.38 ± 1.48 lb ft)	-
4	Tank plug fixing screw	M5	7	6 ± 1 Nm (4.23 ± 0.74 lb ft)	-

Back side

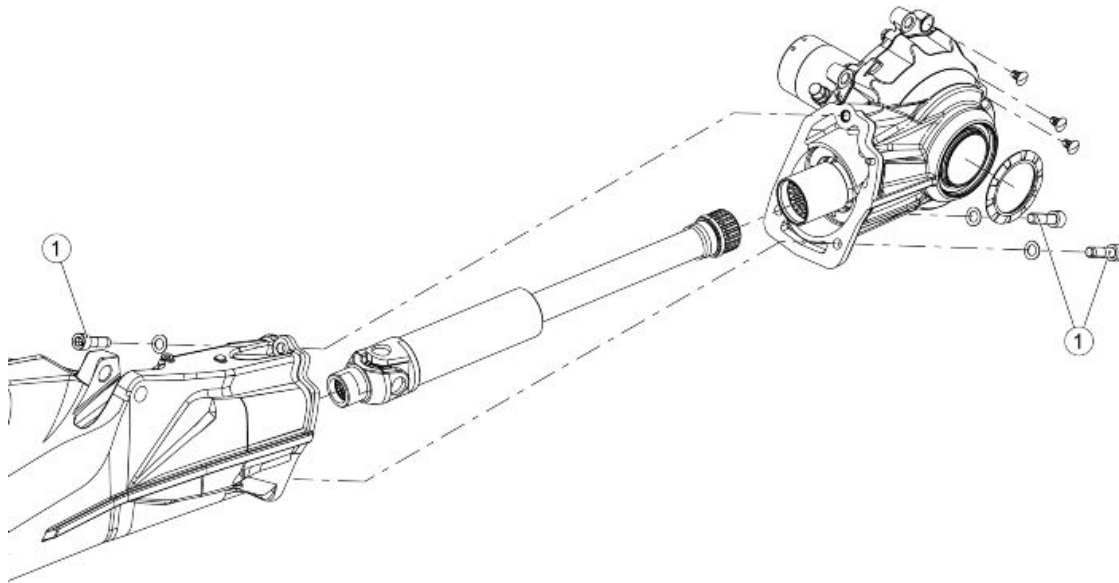

REAR WHEEL TRANSMISSION

Pos.	Description	Type	Quantity	Torque	Notes
1	Screw fixing gearcase to swingarm	M10	3	45 ± 6.75 Nm (33.2 ± 5 lb ft)	-

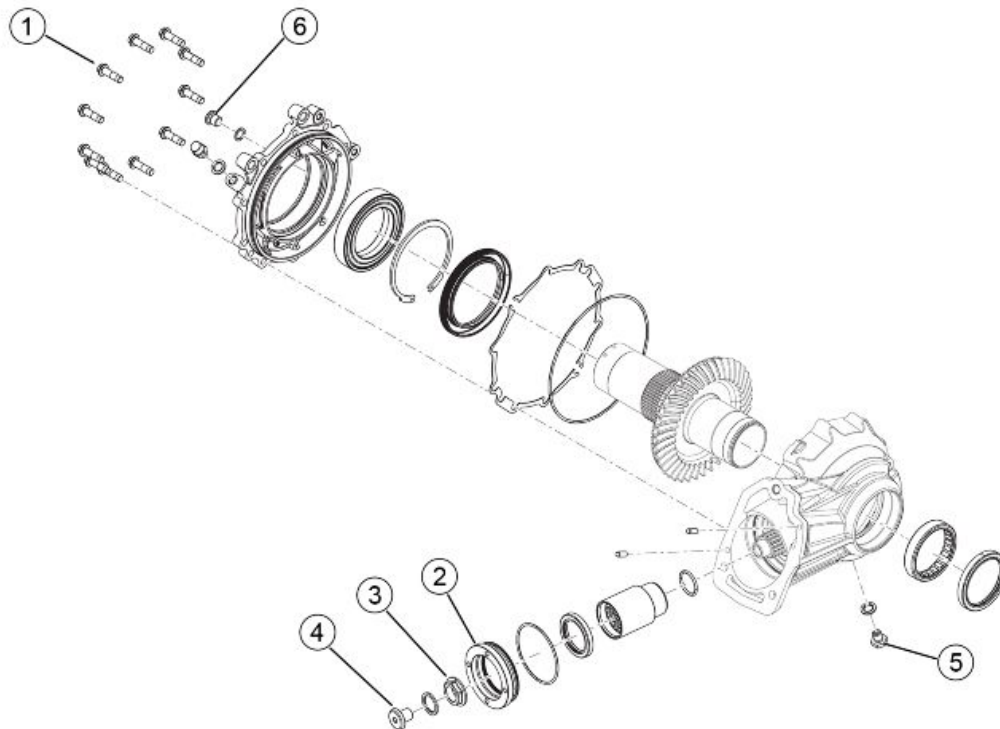

REAR WHEEL TRANSMISSION - COMPONENTS

Pos.	Description	Type	Quantity	Torque	Notes
1	Fixing screw for rear gearbox cover	M8x1	11	25 Nm (18.43 lb ft)	Screws with pre-applied threadlocker
2	Pinion fixing ring nut	-	1	140 Nm (103.25 lb ft)	With Loctite 243
3	Flanged nut fixing pinion	M20x1	1	100 Nm (73.75 lb ft)	With Loctite 243
4	Pinion fastening cap	M14x1	1	50 Nm (36.87 lb ft)	With Loctite 243
5	Oil drainage plug	M10x1.5	1	30 Nm (22.1 lb ft)	-
6	Oil load cap	M12x1.5	1	25 Nm (18.43 lb ft)	-

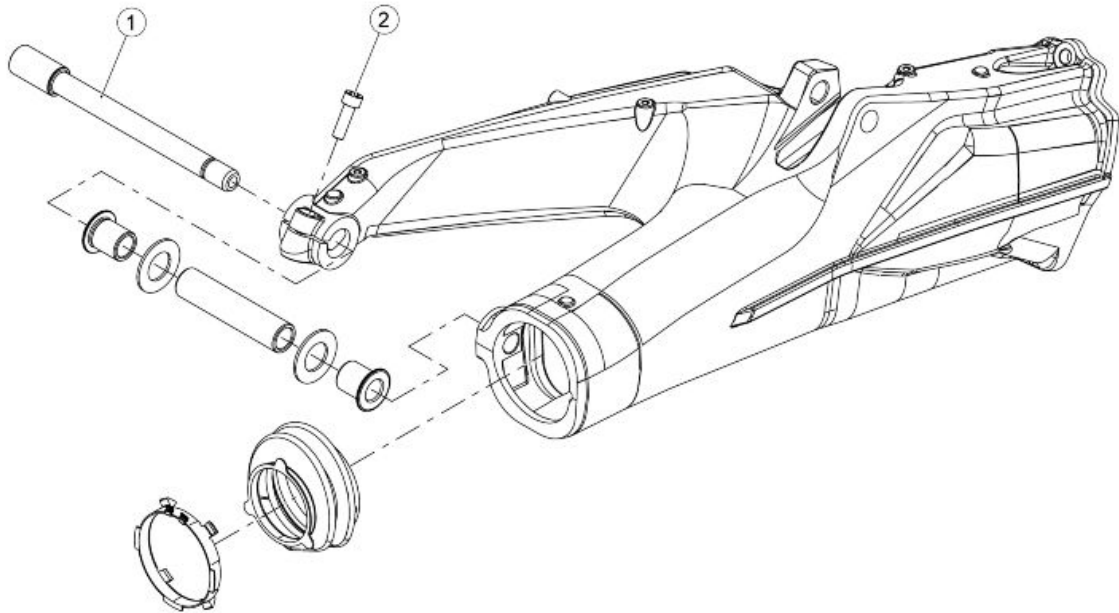
**SWINGARM**

Pos.	Description	Type	Quantity	Torque	Notes
1	Swingarm fastening pin	M16x1.5	1	65 ± 9.75 Nm (47.93 ± 7.2 lb ft)	-
2	Fixing screw for swingarm pin	M8	1	25 ± 3.75 Nm (18.43 ± 2.76 lb ft)	-

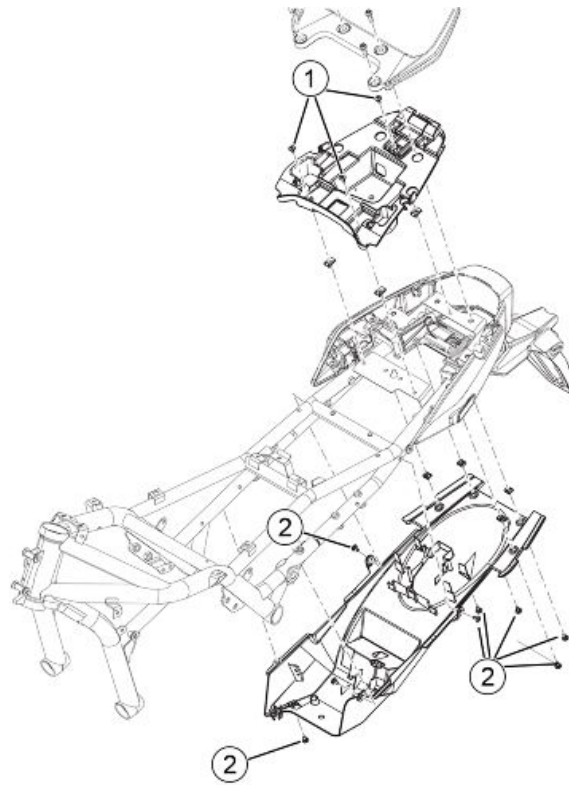

UNDER-SEAT COMPARTMENT

Pos.	Description	Type	Quantity	Torque	Notes
1	Rear storage compartment fixing screw	M5	3	4 ± 0.8 Nm (2.95 ± 0.59 lb ft)	-
2	Fixing screw for lower saddle mounting closure	M5	8	4 ± 0.8 Nm (2.95 ± 0.59 lb ft)	-

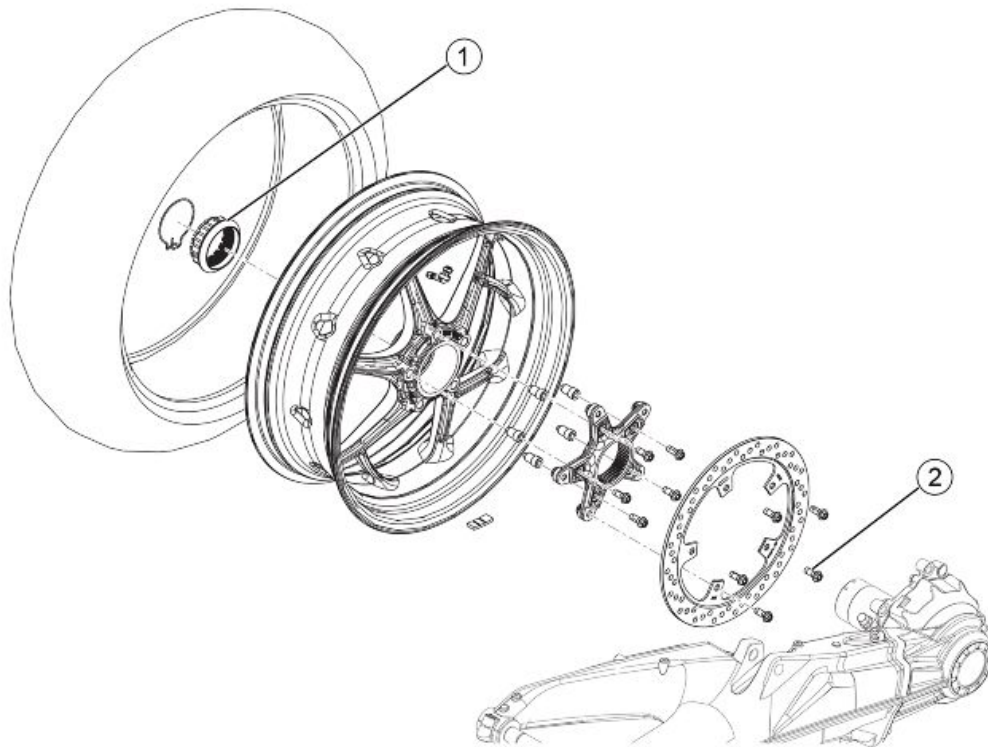

REAR WHEEL

Pos.	Description	Type	Quantity	Torque	Notes
1	Rear wheel nut	M60x2	1	260 ± 39 Nm (191.75 ± 28.76 lb ft)	-
2	Rear brake disc fixing screw	M8	5	30 ± 4.5 Nm (22.12 ± 3.32 lb ft)	Screws with pre-applied threadlocker

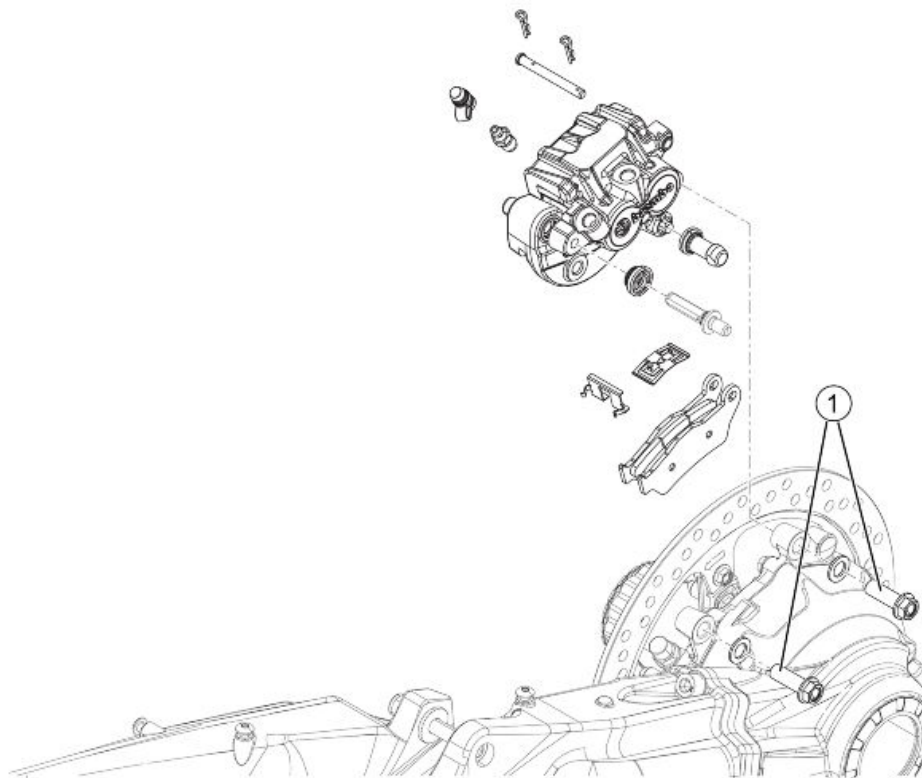

REAR BRAKE CALLIPER

Pos.	Description	Type	Quantity	Torque	Notes
1	Rear brake calliper fixing screw	M10	2	50 ± 5 Nm (36.87 ± 3.7 lb ft)	With a torque wrench

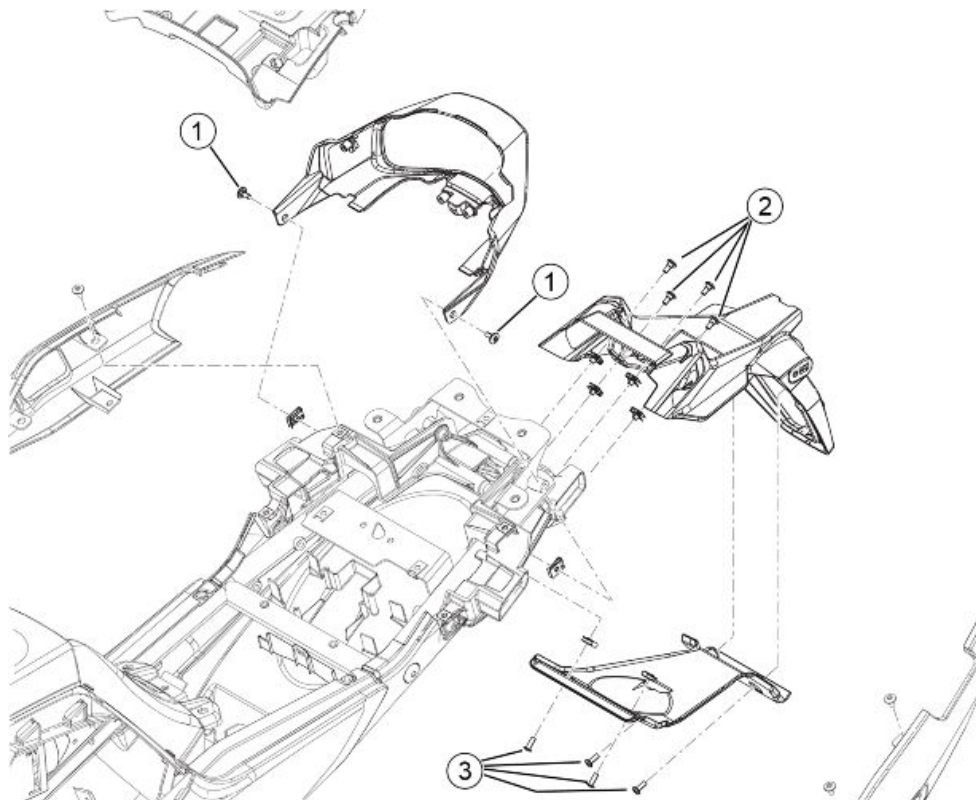

REAR MUDGUARD

Pos.	Description	Type	Quantity	Torque	Notes
1	Fixing screw for centre rear cover	M5	2	4 ± 0.8 Nm (2.95 ± 0.59 lb ft)	-
2	License plate holder fixing screw	M5	4	5.5 ± 1.1 Nm (4.1 ± 0.8 lb ft)	-
3	Fixing screw for lower licence plate holder	SWP 4.9	4	3 ± 0.6 Nm (2.2 ± 0.44 lb ft)	-

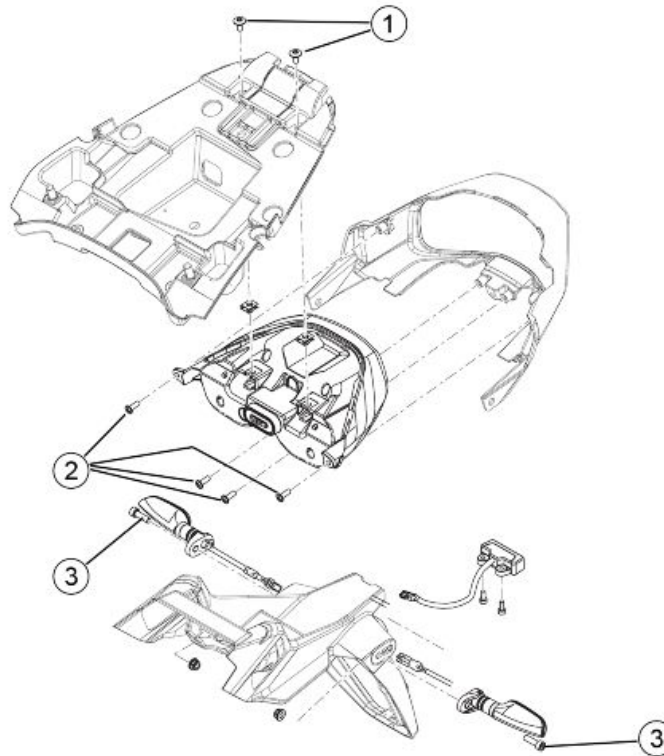
**REAR LIGHTS**

Pos.	Description	Type	Quantity	Torque	Notes
1	Fixing screw for rear light to rear storage cover	M5	2	4 ± 0.8 Nm (2.95 ± 0.59 lb ft)	-
2	Fixing screw for rear light to central rear cover	SWP 4.9	4	3 ± 0.6 Nm (2.2 ± 0.44 lb ft)	-
3	Fixing screw for rear turn indicators to mudguard	M6	2	3 ± 0.6 Nm (2.2 ± 0.44 lb ft)	With self-locking nut

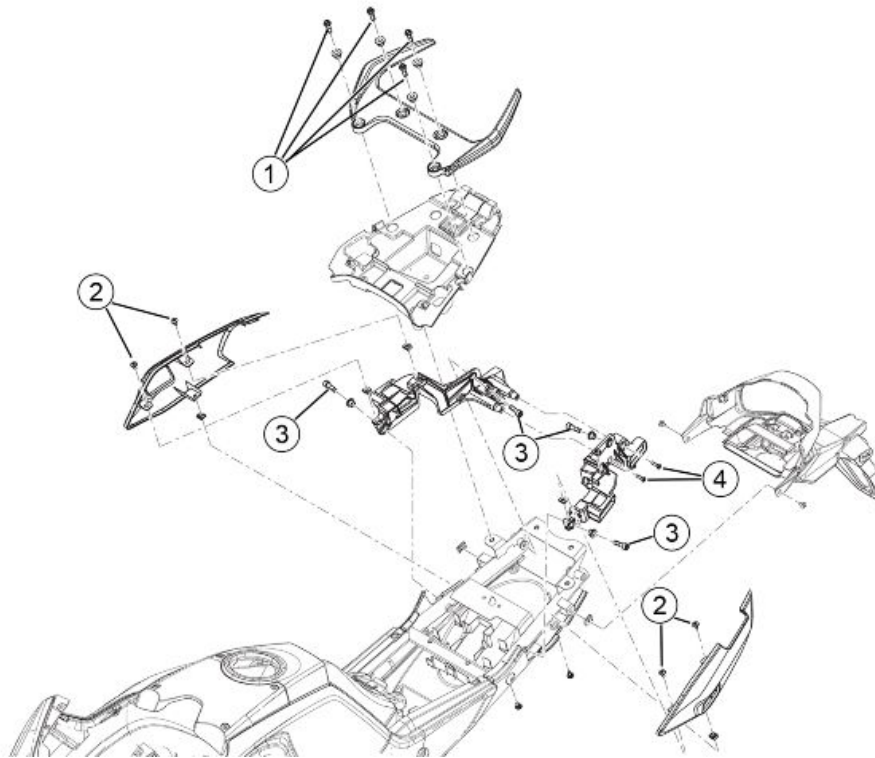

REAR BODYWORK

Pos.	Description	Type	Quantity	Torque	Notes
1	Fixing screw for passenger grab handle	M8	4	34 ± 5 Nm (25.1 ± 3.7 lb ft)	Screws with pre-applied threadlocker
2	Fixing screw for rear side covers	M5	4	4 ± 0.8 Nm (2.95 ± 0.59 lb ft)	-
3	Front fixing screw for luggage holder	M8	4	34 ± 6.8 Nm (25.1 ± 5 lb ft)	Screws with pre-applied threadlocker
4	Rear fixing screw for luggage holder	SWP 4.9	2	3.5 ± 0.7 Nm (2.6 ± 0.52 lb ft)	-

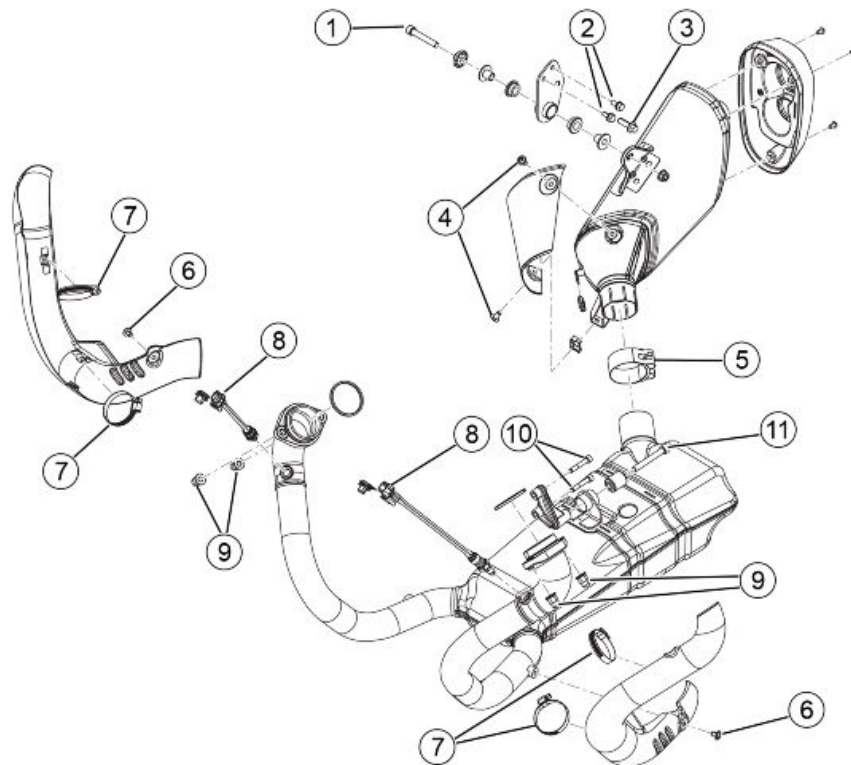

SILENCER

Pos.	Description	Type	Quantity	Torque	Notes
1	Screw fastening outer silencer support bracket	M8	1	25 ± 5 Nm (18.43 ± 3.68 lb ft)	-
2	Upper silencer fixing screw to the footrest	M6	2	10 ± 2 Nm (7.37 ± 1.47 lb ft)	-
3	Lower silencer fixing screw to the footrest	M8	1	25 ± 5 Nm (18.43 ± 3.68 lb ft)	-
4	Fixing screw for silencer manifold protection	M6	2	10 ± 2 Nm (7.37 ± 1.47 lb ft)	Screw with pre-applied threadlocker
5	Fastening the silencer to the exhaust manifold	Pipe clamp	1	25 ± 5 Nm (18.43 ± 3.68 lb ft)	-
6	Heat shield protection fastening screws	M6	2	10 ± 2 Nm (7.37 ± 1.47 lb ft)	Screw with pre-applied threadlocker
7	Heat shield protection fixing	Pipe clamp	4	3 ± 0.6 Nm (2.21 ± 0.44 lb ft)	-
8	Lambda probe fastener	M12x1.25	2	25 ± 5 Nm (18.43 ± 3.68 lb ft)	-
9	Exhaust manifold flange fastening nuts	M8	4	25 ± 5 Nm (18.43 ± 3.68 lb ft)	-
10	Fixing screw for silencer support outer bracket	M6	2	10 ± 2 Nm (7.37 ± 1.47 lb ft)	-
11	Lower fixing screw for exhaust manifold	M8	1	25 ± 5 Nm (18.43 ± 3.68 lb ft)	-

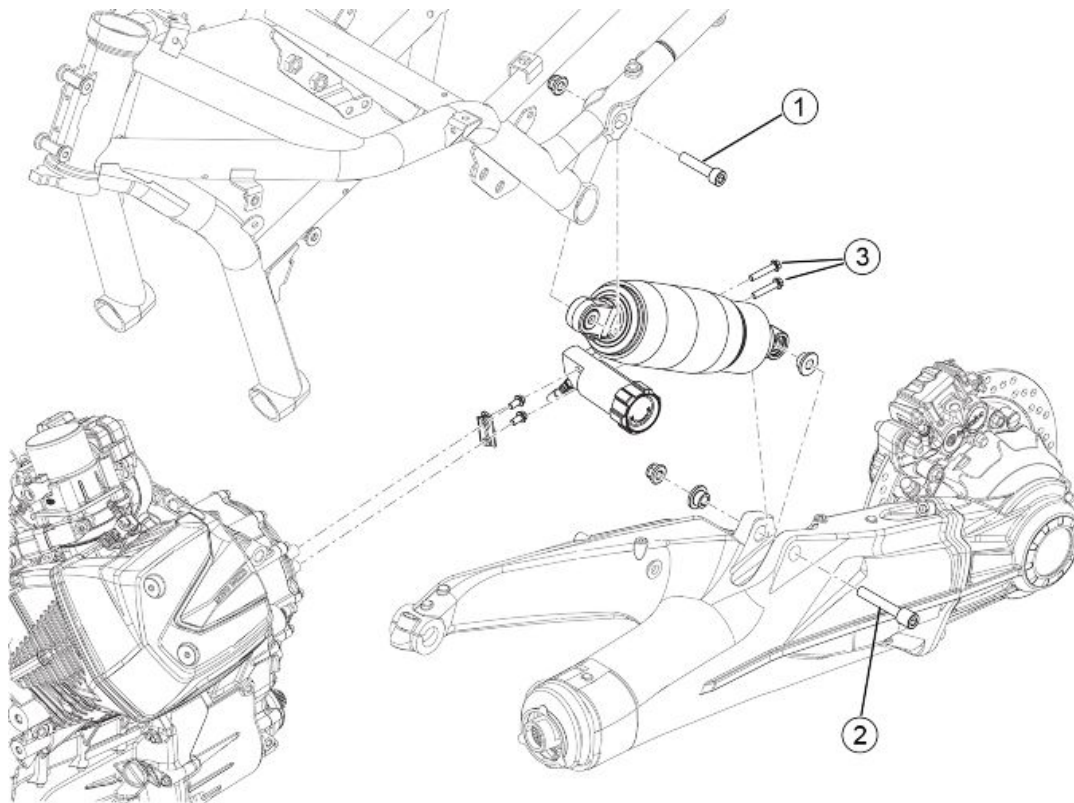

REAR SHOCK ABSORBER

Pos.	Description	Type	Quantity	Torque	Notes
1	Upper shock absorber fixing screw	M10	1	50 ± 7.5 Nm (36.87 ± 5.53 lb ft)	-
2	Lower shock absorber clamping screw	M10	1	50 ± 7.5 Nm (36.87 ± 5.53 lb ft)	-
3	Fixing screw for preload tank to bracket	M6	2	10 ± 2 Nm (7.37 ± 1.47 lb ft)	-

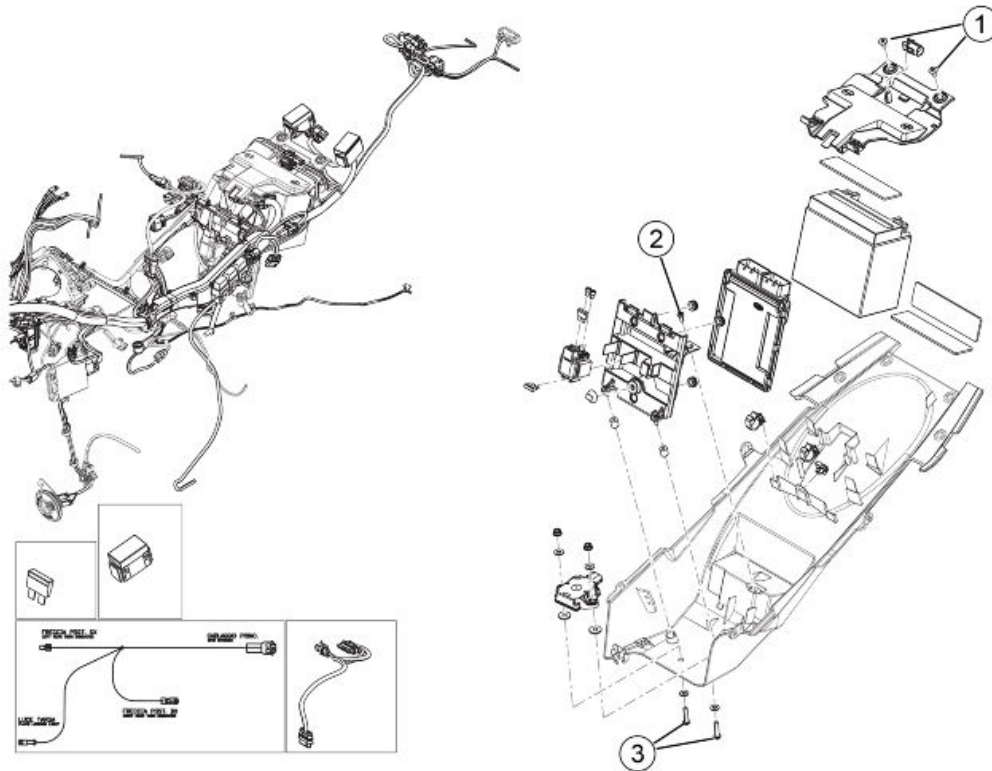

REAR ELECTRICAL SYSTEM





Pos.	Description	Type	Quantity	Torque	Notes
1	Fixing screw for battery cover to chassis	M5	2	4 ± 0.8 Nm (2.95 ± 0.59 lb ft)	-
2	Fixing screw for ECU holder	SWP 4.9	1	3 ± 0.45 Nm (2.2 ± 0.33 lb ft)	-
3	Fixing screw for IMU ECU to lower seat latch	M6	2	7 ± 1 Nm (5.16 ± 0.73 lb ft)	-



INDEX OF TOPICS

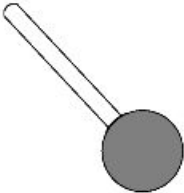

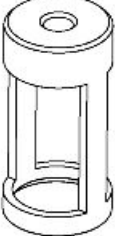

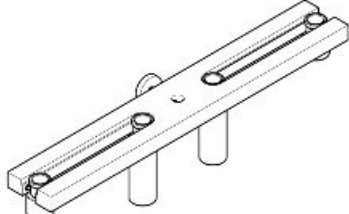
SPECIAL TOOLS

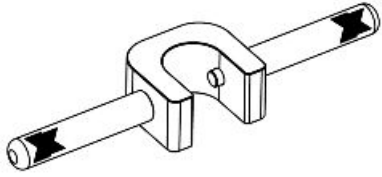

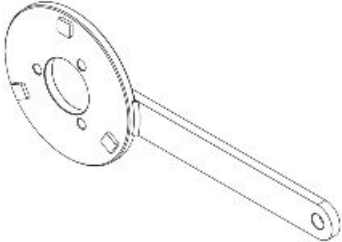
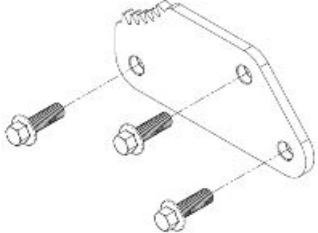
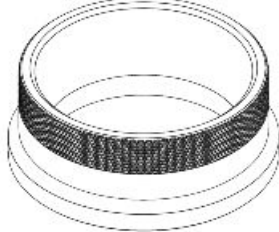
S-TOOLS

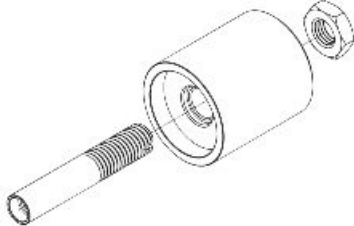
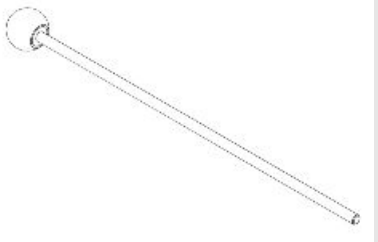
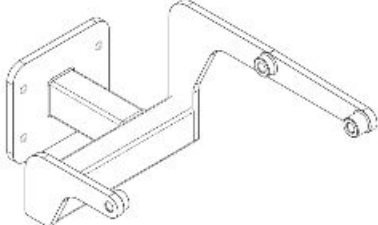
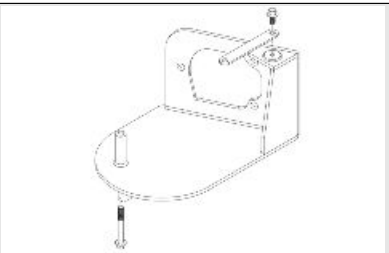
SPECIAL TOOLS

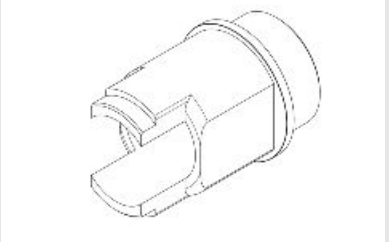
Stores code	Description	
020851Y	Camshaft timing pin	
020382Y	Valve cotters equipped with part 012 removal tool	
020853Y	Compresses intake valve springs	
020376Y	Adaptor handle	
020360Y	52 x 55 mm adaptor	
020714Y	Dial gauge mount	

Stores code	Description	
020888Y	Pre-load tube clamp	
020922Y	Diagnostic tool	
021017Y	OBD cable for E5 vehicles	
021058Y	Clutch retainer	
021059Y	Primary retainer	
021061Y	Ring clamp	
021062Y	Crankshaft support U-bolt	

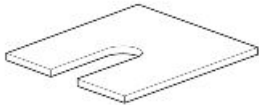
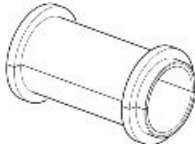
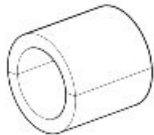
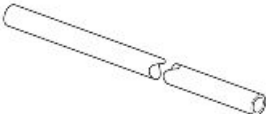
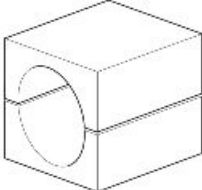
Stores code	Description	
021063Y	Water pump seal insertion tool	
021064Y	Large pin for engine timing	
021065Y	Engine support frame	
021066Y	Gearbox mounting	
021067Y	Pinion side fixing ring nut socket	
021068Y	Ring gear side roller cage extraction punch	
021069Y	52 mm adaptor for single arm lift stand	

Stores code	Description	
AP8140148	Plunger-spacer separator plate	
AP8140189	Tool for fitting oil seal for 43 mm (1.69 in) diameter hole	
AP8140146	Weight	
AP8140150	Bored shaft for bleeding plunger air	
AP8140149	Guard for assembly operations	
021072Y	Right chain tensioner	
021073Y	Central chain tensioner	

Stores code

Description

021074Y

Left chain tensioner



01761-04

Ohlins fork cap ring nut

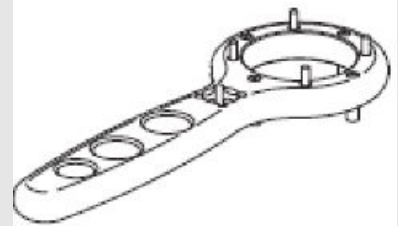

Commercially available tool

Bushing of 65 mm

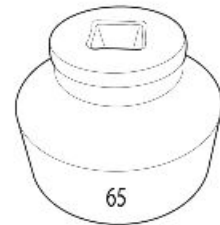

INDEX OF TOPICS

MAINTENANCE

MAIN

Scheduled maintenance table

NOTE

CARRY OUT MAINTENANCE OPERATIONS AT HALF THE INTERVALS SPECIFIED IF THE VEHICLE IS USED IN PARTICULAR RAINY OR DUSTY CONDITIONS, OFF ROAD OR FOR TRACK USE.

NOTE

THE TIMES LISTED ON THE SCHEDULED MAINTENANCE TABLE INCLUDE TIME DEDICATED TO MANAGEMENT ACTIVITIES.

SCHEDULED MAINTENANCE TABLE VALID FOR EU-USA-LATAM-JA MARKETS

SCHEDULED MAINTENANCE TABLE

I: Check and clean, adjust, lubricate or replace, if necessary

C: clean

R: replace

A: adjust

(1): Replace in case of leaks

(2): Check every month

(3): Check every 500 km (310 miles)

(4): Check and clean, adjust or replace if necessary every 1000 km (621 miles)

(5): Replace at whichever of the following occurs first: 48,000 km (29,800 mi) or 4 years

km x 1,000 (mi x 1,000)	1,5 (0.9)	12 (7.5)	24 (14.9)	36 (22.4)	48 (29.8)	60 (37.3)	72 (44.7)	EVERY 12 MONTH S	EVERY 24 MONTH S
Engine oil filler plug O-ring	I	I	I	I	I	I	I	I	I
Fork plug O-ring					I				
Spark plugs		I	R	I	R	I	R		
Alternator belt		I	R	I	R	I	R		R
Steering bearings and steering play	I	I	I	I	I	I	I	I	I
Front wheel bearings		I	I	I	I	I	I	I	I
Diagnosis by tool	I	I	I	I	I	I	I	I	I
Brake discs - Pads wear (4)	I	I	I	I	I	I	I	I	I
Air filter		R	R	R	R	R	R		
Engine oil filter	R	R	R	R	R	R	R	R	R
Vehicle general operation	I	I	I	I	I	I	I	I	I
Valve clearance			I		I		I		
Head cover gasket	I	I	I	I	I	I	I		
Engine oil discharge plug aluminium gasket	R	R	R	R	R	R	R	R	R
Transmission oil discharge plug gasket			R		R		R		
Gasket for the engine oil filter fastening screw	R	R	R	R	R	R	R	R	R
Brake systems	I	I	I	I	I	I	I	I	I
Light circuit	I	I	I	I	I	I	I	I	I
Safety switches	I	I	I	I	I	I	I	I	I
Brake fluid	I	I	I	I	I	I	I	I	R
Clutch fluid	I	I	I	I	I	I	I	I	R
Coolant	I	I	I	I	I	I	I	I	R
Fork oil (5)					R				
Engine oil (3)	R	R	R	R	R	R	R	R	R
Final drive oil			R		R		R		
Headlight aiming		I	I	I	I	I	I		
Fork oil seals (1)		I	I	I		I	I		
Tyres - pressure / wear (2)	I	I	I	I	I	I	I	I	I
Transmission oil filler plug washer			R		R		R		
Nut/bolt tightness	I	I	I	I	I	I	I		
Suspensions and stability			I		I		I	I	I
Head cover fastening screws dampers	I	I	I	I	I	I	I		
Filter box drain plug		C	C	C	C	C	C	C	C
Brake lines		I	I	I	I	I	I		
Fuel pipes		I	I	I	I	I	I	I	I

km x 1,000 (mi x 1,000)	1,5 (0.9)	12 (7.5)	24 (14.9)	36 (22.4)	48 (29.8)	60 (37.3)	72 (44.7)	EVERY 12 MONTH S	EVERY 24 MONTH S
Labour time (minutes)	70	170	200	170	290	170	200	60	60

NOTE

AT EACH SCHEDULED MAINTENANCE MUST BE VERIFIED WITH THE DIAGNOSTIC TOOL IF THERE ARE ERRORS AND THE IF THE PARAMETERS ARE CORRECT. ENSURE THAT THE VEHICLE CALIBRATION IS UP TO DATE AFTER UPDATING THE DIAGNOSTIC TOOL.

CAUTION

AFTER THE PROVIDED MAINTENANCE PROGRAM IS INDICATED TO PROCEED WITH THE MAINTENANCE OF THE VEHICLE STARTING FROM THE SERVICE OF 10,000 Km OR 10 MONTHS

SCHEDULED MAINTENANCE TABLE RESERVED FOR THE ASIA-PACIFIC MARKET

SCHEDULED MAINTENANCE TABLE

I: Check and clean, adjust, lubricate or replace, if necessary

C: clean

R: replace

A: adjust

(1): Replace in case of leaks

(2): Check every month

(3): Check every 500 km (310 miles)

(4): Check and clean, adjust or replace if necessary every 1000 km (621 miles)

(5): Replace at whichever of the following occurs first: 48,000 km (29,800 mi) or 4 years

km x 1,000 (mi x 1,000)	1,5 (0.9)	12 (7.5)	24 (14.9)	36 (22.4)	48 (29.8)	60 (37.3)	72 (44.7)
Engine oil filler plug O-ring	I	I	I	I	I	I	I
Fork plug O-ring					I		
Spark plugs		I	R	I	R	I	R
Alternator belt		I	R	I	R	I	R
Steering bearings and steering play	I	I	I	I	I	I	I
Front wheel bearings		I	I	I	I	I	I
Diagnosis by tool	I	I	I	I	I	I	I
Brake discs - Pads wear (4)	I	I	I	I	I	I	I
Air filter		R	R	R	R	R	R
Engine oil filter	R	R	R	R	R	R	R
Vehicle general operation	I	I	I	I	I	I	I
Valve clearance			I		I		I
Head cover gasket	I	I	I	I	I	I	I
Engine oil discharge plug aluminium gasket	R	R	R	R	R	R	R
Transmission oil discharge plug gasket			R		R		R
Gasket for the engine oil filter fastening screw	R	R	R	R	R	R	R
Brake systems	I	I	I	I	I	I	I
Light circuit	I	I	I	I	I	I	I
Safety switches	I	I	I	I	I	I	I
Brake fluid	I	I	I	I	I	I	I
Clutch fluid	I	I	I	I	I	I	I
Coolant	I	I	I	I	I	I	I
Fork oil (5)					R		
Engine oil (3)	R	R	R	R	R	R	R
Final drive oil			R		R		R
Headlight aiming		I	I	I	I	I	I
Fork oil seals (1)		I	I	I		I	I
Tyres - pressure / wear (2)	I	I	I	I	I	I	I
Transmission oil filler plug washer			R		R		R
Nut/bolt tightness	I	I	I	I	I	I	I
Suspensions and stability			I		I		I
Head cover fastening screws dampers	I	I	I	I	I	I	I
Filter box drain plug		C	C	C	C	C	C
Brake lines		I	I	I	I	I	I
Fuel pipes		I	I	I	I	I	I

km x 1,000 (mi x 1,000)	1,5 (0.9)	12 (7.5)	24 (14.9)	36 (22.4)	48 (29.8)	60 (37.3)	72 (44.7)
Labour time (minutes)	70	170	200	170	290	170	200

NOTE

AT EACH SCHEDULED MAINTENANCE MUST BE VERIFIED WITH THE DIAGNOSTIC TOOL IF THERE ARE ERRORS AND THE IF THE PARAMETERS ARE CORRECT. ENSURE THAT THE VEHICLE CALIBRATION IS UP TO DATE AFTER UPDATING THE DIAGNOSTIC TOOL.

CAUTION

AFTER THE PROVIDED MAINTENANCE PROGRAM IS INDICATED TO PROCEED WITH THE MAINTENANCE OF THE VEHICLE STARTING FROM THE SERVICE OF 10,000 Km OR 10 MONTHS

Recommended products

Piaggio Group recommends the use of products from its Castrol official partner for the scheduled maintenance of its vehicles.

Only use lubricants and fluids which meet or exceed the performance characteristics specified.

This also applies when topping up only.



TABLE OF RECOMMENDED PRODUCTS

Product	Description	Specifications
Engine oil 10W -50	Synthetic-based lubricant for high performance four-stroke engines.	SAE 10W 50; API SL; JASO MA2
75W-140 lubricant for gearboxes and transmissions	Synthetic lubricant for gearboxes and transmissions	SAE 75W-140 - API GL5
Anti-freeze liquid, ready to use, colour red	Glycol ethylene based antifreeze liquid with organic additive technology corrosion inhibitor. Colour red, ready to use.	ASTM D 3306 - ASTM D 4656 - ASTM D 4985 - CUNA NC 956-16
Fork oil 7.5W	Fork oil.	SAE 7.5W
Molybdenum disulphide grease	Lithium grease with molybdenum disulphide.	Grey black grease
Petroleum jelly	neutral grease for battery terminals	-
DOT 4 brake fluid	Synthetic brake fluid.	SAE J 1703; FMVSS 116; ISO 4925; CUNA NC 956 DOT4

Spark plug

REMOVAL AND CHECK

- Remove the fixing screw (1).



- Remove the spark plug cover (2).

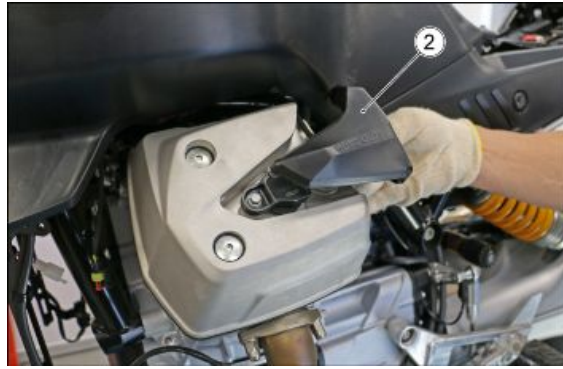

- Release the cable from their seats on the valve cover.



- Remove the fixing screw (3) of the coil.



- Extract the coil (4) from the head.



- Using a dedicated wrench, unscrew the spark plug and remove it from the head.



- Check the state of wear of the spark plug and measure the distance between the electrodes.
- If the value does not lie within the specified value, replace the spark plug with a new one.

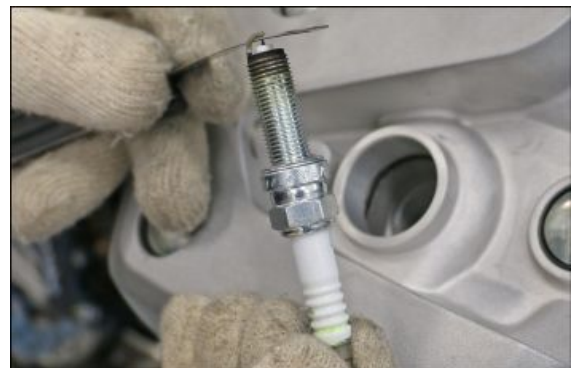

Characteristic

Spark plug electrode gap

0.7 mm (0.028 in)

Transmission fluid

Replacement

CAUTION

THE UNIT MUST BE HOT WHEN THE OIL IS CHANGED AS UNDER SUCH CONDITIONS OIL IS FLUID AND THEREFORE EASY TO DRAIN.

NOTE

RIDE SOME km (miles) TO WARM UP ENGINE OIL

Place a suitable container with a capacity greater than 250 cc (15.26 cu in) under the drain plug (1).



Loosen the drain plug without removing it.



Unscrew and remove the filler plug (2).



Completely unscrew and remove the drain plug. Drain the oil into the container for at least 5 minutes for oil to drain out completely.



Once the oil has drained out, screw in and tighten the drain plug with its washer to the prescribed torque.

Remove metal residues attached to the drain plug magnet.

NOTE

DURING REPLACEMENT, USE A NEW SEALING WASHER.

Locking torques (N*m)

Oil drainage plug 30 Nm (22.1 lb ft)



Using a special syringe, fill in with new oil through the filler cap.

CAUTION

DO NOT ADD ADDITIVES OR OTHER SUBSTANCES TO THE FLUID. WHEN USING A FUNNEL OR ANY OTHER ELEMENT, MAKE SURE IT IS PERFECTLY CLEAN.

Recommended products

75W-140 lubricant for gearboxes and transmissions Synthetic lubricant for gearboxes and transmissions

SAE 75W-140 - API GL5

Characteristic

Bevel gear set oil

250 cm³ (15.26 cu in)

Bevel gear oil (in case of replacement)

225 cc (13.73 cu in) MAX



Screw and tighten the filler cap with its washer to the prescribed torque.

NOTE

DURING REPLACEMENT, USE A NEW SEALING WASHER.

CAUTION

IF IT IS NECESSARY TO INSTALL A NEW TRANSMISSION GEARBOX, PAY SPECIAL ATTENTION TO THE PROCEDURE BELOW

Locking torques (N*m)

Oil load cap 25 Nm (18.43 lb ft)



Since they are already run-in at the factory, the complete transmission boxes coming from the Spare parts department contain a minimum residual oil quantity and therefore after installing them on the vehicle, the following procedure must be performed:

- Open the filler plug and drain any residual oil from the lower drain plug leaving it to drip for at least 5 minutes.
- Refit and tighten the lower drain plug and fill with oil from the filler cap.
- Refit and tighten the filler cap.
- Assemble the breather cap. If the gearbox arrived with the breather plug already assembled, remove



it and blow it with compressed air to carefully remove any oil residues.

CAUTION

DURING REPLACEMENT, USE A NEW SEALING WASHER FOR THE BREATHER CAP.

Engine oil

Check

Check the engine oil level frequently.

NOTE

CARRY OUT MAINTENANCE OPERATIONS AT HALF THE INTERVALS SPECIFIED IF THE VEHICLE IS USED IN PARTICULAR RAINY OR DUSTY CONDITIONS, OFF ROAD OR FOR TRACK USE.

WARNING

THE OIL LEVEL MUST BE CHECKED WHEN THE ENGINE IS WARM.

CAUTION

DO NOT LET THE ENGINE IDLE WITH THE VEHICLE AT A STANDSTILL TO WARM UP THE ENGINE AND OBTAIN THE OPERATING TEMPERATURE OF ENGINE OIL. THE CORRECT PROCEDURE IS TO CHECK AFTER A JOURNEY OR AFTER RUNNING 15 km (10 mi) ON AN EXTRA-URBAN ROUTE (ENOUGH TO RAISE ENGINE OIL TEMPERATURE).

- Shut off the engine and wait a few seconds;
- Keep the vehicle upright with both wheels on the ground;
- Make sure that the vehicle is on a level surface;
- Unscrew the oil filler cap with dipstick;



- Wipe the dipstick clean and put the dipstick and filler cap back into place without tightening;
- Remove the cap and dipstick again and check the engine oil level;
- The level is correct if it reaches the "MAX" level approximately. Otherwise top off the engine oil.

**CAUTION**

THE OIL LEVEL MUST NEVER DROP BELOW THE MINIMUM MARKING OR EXCEED THE MAXIMUM MARKING;

AN OIL LEVEL NOT WITHIN THE MINIMUM AND MAXIMUM MARKINGS MAY CAUSE SEVERE ENGINE DAMAGE.

Replacement

NOTE

HOT OIL IS MORE FLUID AND WILL DRAIN OUT MORE EASILY AND COMPLETELY.

Place a collection container of suitable capacity under the drain plug (1).

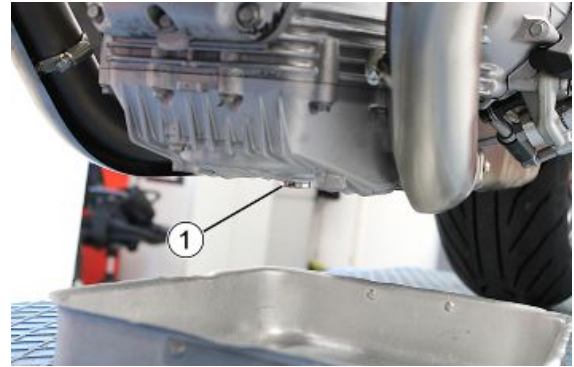

Unscrew and remove the filler plug (2).



Unscrew the drainage cap.



Remove the drain plug and allow the oil to drip into the container for a few minutes.



Once the oil has drained out, screw in and tighten the drain plug with its washer to the prescribed torque.

Remove metal residues attached to the drain plug magnet.

NOTE

DURING REPLACEMENT, USE A NEW SEALING WASHER.



DO NOT DISPOSE OF OIL IN THE ENVIRONMENT. DISPOSE OF ENGINE OIL IN A SEALED CONTAINER AND TAKE IT TO YOUR SUPPLIER OR TO THE NEAREST USED OIL COLLECTION CENTRE. IT IS ADVISABLE TO WEAR LATEX GLOVES WHEN SERVICING THE VEHICLE.

Locking torques (N*m)

Oil drainage plug 20 ± 2 Nm (14.75 ± 1.47 lb ft)

Fill with new oil through the filler cap.

CAUTION

DO NOT ADD ADDITIVES OR OTHER SUBSTANCES TO THE FLUID. WHEN USING A FUNNEL OR ANY OTHER ELEMENT, MAKE SURE IT IS PERFECTLY CLEAN.

Recommended products

Engine oil 10W -50 Synthetic-based lubricant for high performance four-stroke engines.

SAE 10W 50; API SL; JASO MA2

Characteristic**Engine oil**

Oil change and oil filter replacement: 4900 cc in (299.02 cu in)

Screw and tighten the filler cap with its washer to the prescribed torque.

NOTE

DURING REPLACEMENT, USE A NEW SEALING WASHER.

Locking torques (N*m)

Oil load cap 2 ± 0.5 Nm (1.47 ± 0.37 lb ft)



Engine oil filter

Loosen the 3 screws securing the engine oil filter cover.



Place a container with adequate collecting capacity at the engine oil filter cover and completely unscrew the 3 fixing screws.



DO NOT DISPOSE OF OIL IN THE ENVIRONMENT. DISPOSE OF ENGINE OIL IN A SEALED CONTAINER AND TAKE IT TO YOUR SUPPLIER OR TO THE NEAREST USED OIL COLLECTION CENTRE.



Remove engine oil filter cover with the spring.



Remove the engine oil filter.



When reassembling, use a new O-ring seal for the engine oil filter cover.



Insert the new engine oil filter.

NOTE

NEVER REUSE AN OLD FILTER.



Refit the cover with the spring facing downwards.



Screw in and tighten the 3 fixing screws for the engine oil filter cover to the prescribed torque.

Locking torques (N*m)

**Fixing screws for engine oil filter cover 12 ± 1 Nm
(8.85 ± 0.73 lb ft)**



Air filter

REMOVAL

- Remove the four fixing screws and then remove the cover (1) of the tank.

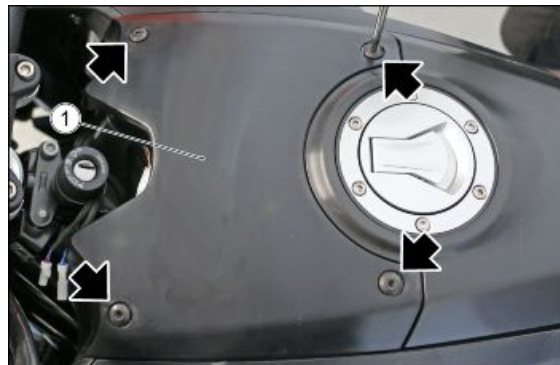

- Remove the four fixing screws and then remove the cover (2) of the filter box.



- Remove the two fixing screws indicated in the figure.

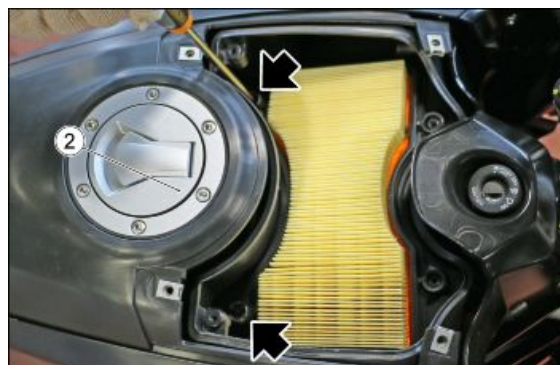

- Remove the air filter support (3) from the filter box.



- Remove the air filter (4) from the filter box.



Air filter housing

Air filter housing removal

- First remove the fuel tank.
- Loosen the two clamps (1) of the throttle body manifolds.



- Open the clamp and disconnect the left breather pipe (2) from the filter box.



- Remove the left fixing screw of the filter box.

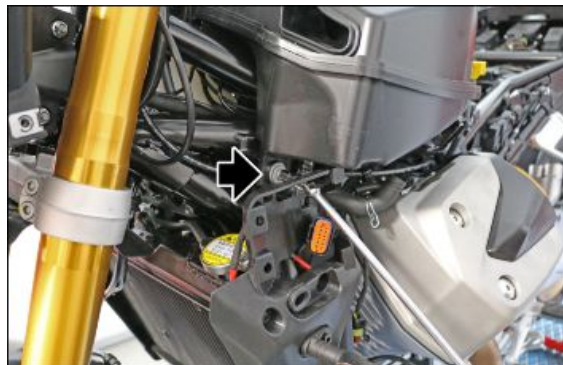

- Open the clamp and disconnect the right breather pipe (3) from the filter box.



- Remove the right fixing screw of the filter box.

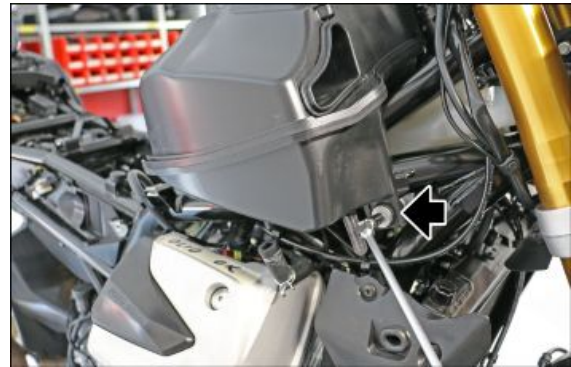

- Remove the filter box from the vehicle by extracting it upward.



DURING REASSEMBLY, ENSURE THE CORRECT INSERTION OF THE AIR FILTER HOUSING MANIFOLDS ON THE THROTTLE BODIES.



- To remove the air filter inside the filter box, carry out the procedure described in paragraph "air filter" in the "maintenance" chapter.

See also

Air filter

Checking the valve clearance

- Install a workshop stand to the rear wheel of the vehicle so as to lift it from the ground.
- Remove the spark plugs from both heads.
- Turn the rear wheel until the left-hand piston is at top dead centre (TDC) and in compression (all cams facing up and with the lobes converging).



NOTE

Checking the valve clearance should be performed first on the left head.

- Remove the three fixing screws (1).

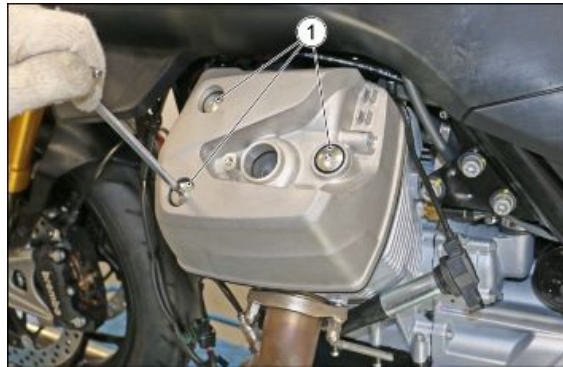

- Remove the valve cover (2) from the head.



- Using a feeler gauge reed valve (3), measure the distance between the rocker (4) and the valve (5).

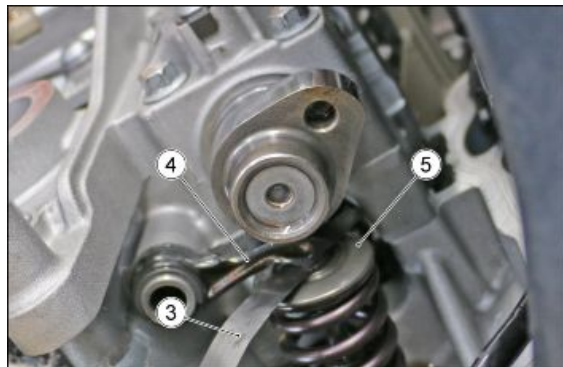

Characteristic

Intake valve clearance

0.10 - 0.15 mm (0.0039 - 0.0059 in)

Exhaust valve clearance

0.30 - 0.35 mm (0.0118 - 0.0138 in)

- Repeat the operation for the remaining valves.

If the valve clearance is not within the tolerance range, adjust the valve clearance as shown below.

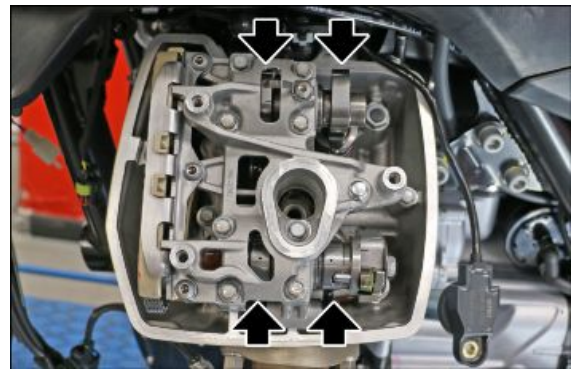

- Turn the rear wheel and bring the right-hand piston to TDC and in compression (the lobes of the camshafts must face upwards and diverge from each other, as shown in the figure).
- Repeat the valve clearance control operations on the right head.

If the valve clearance is not within the tolerance range, adjust the valve clearance as shown below.



VALVE CLEARANCE ADJUSTMENT RIGHT HEAD

- Preventively remove: radiator, timing cover, spark plug valve covers.
- Turn the engine counter-clockwise and bring the RH piston to Top Dead Centre.

NOTE

THE HOLE ON THE PINION MARKED "PMS DX" MUST BE ALIGNED WITH THE HOLE ON THE CRANKCASE.

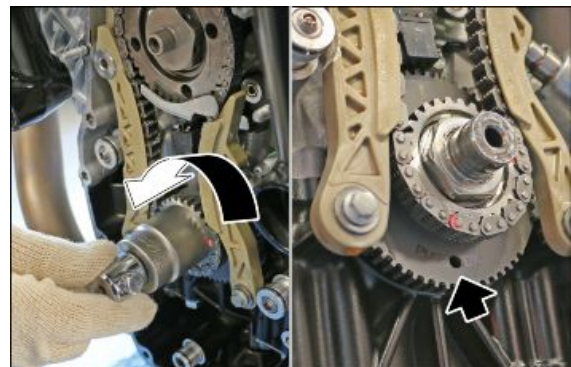

- Insert the centring pin in the crankshaft pinion, making sure to intercept the holes of the pinion and of the crankcase.

Specific tooling

020851Y Camshaft timing pin



- Check that the cam lobes are divergent from each other.



- Insert the special tool (1) into the hole on the exhaust camshaft.

Specific tooling

021064Y Large pin for engine timing

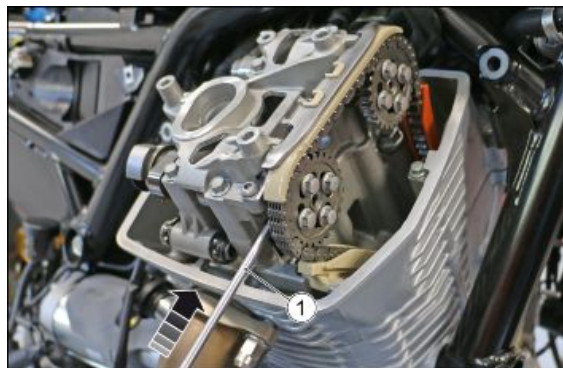

- Continue to insert the tool (1) to intercept the hole on the intake manifold.

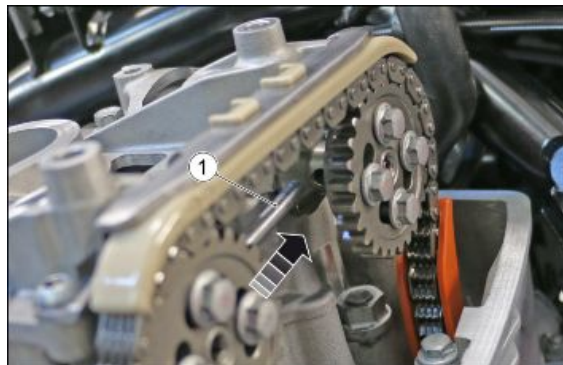

- For safety, mark the position of the sprockets on the chain and of the chain in relation to the upper chain tensioner shoe.

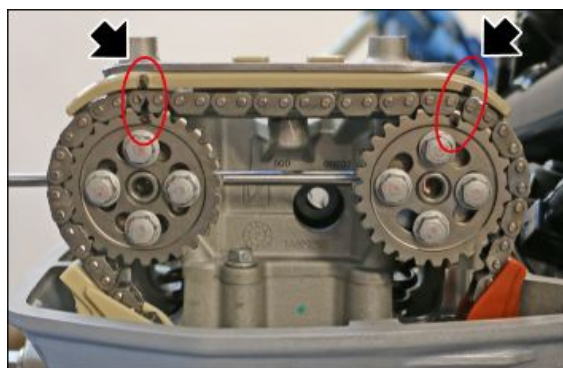

- Remove the fixing screws of the upper mounting, following the sequence A-B-C-D-E-F-G-H-I.

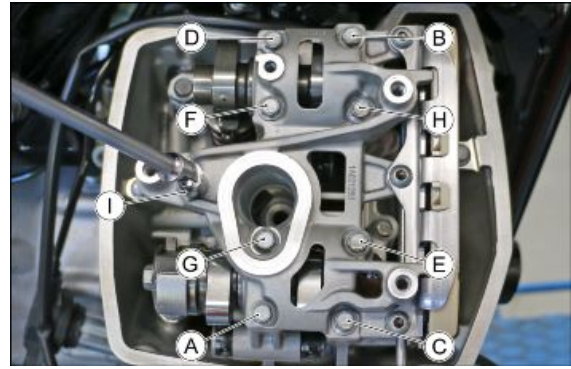

- Remove the upper mounting (2) from the head.



- Remove the tool (1) from the camshafts, taking care that the chain tensioner, still loaded with oil, does not cause the shafts to drop from the head.



- Remove the intake camshaft (3).

CAUTION

MAKE SURE THAT THE CHAIN TENSIONER DOES NOT COME OUT OF ITS SEAT AND FALL INTO THE ENGINE.

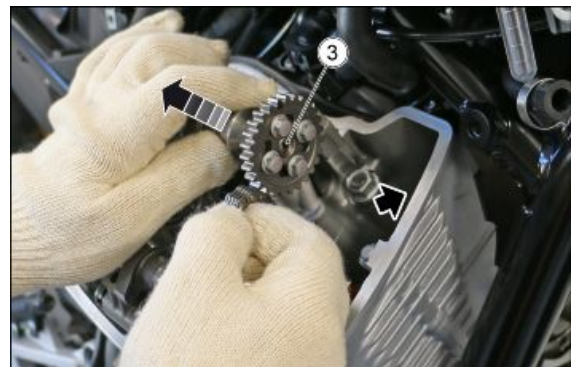

- Remove the exhaust camshaft (4).



- Fasten the timing chain to the vehicle, taking care that it does not get out of the sprocket on the service shaft.

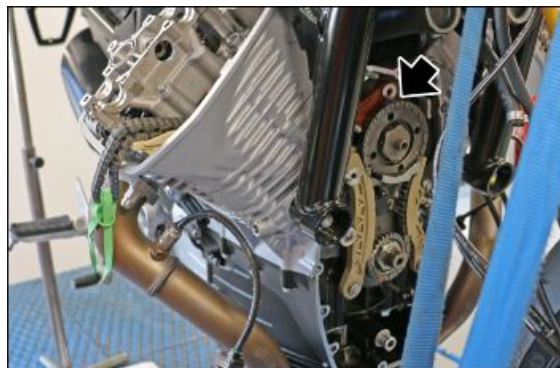

- Lift the rocker arm of the valve(s) to be adjusted.

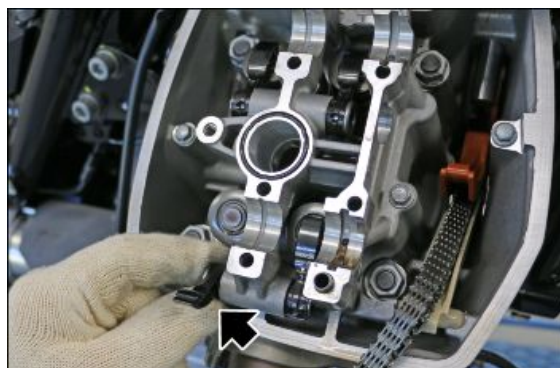

- Using a magnet, remove the calibrated pads (5) from the valves to be adjusted and replace them with pads of a suitable thickness to achieve the specified valve clearance.



To find the thickness of the pads to be installed, use the following formula:

Installed pad thickness + measured clearance - specified clearance = new pad thickness

CAUTION



PAY CLOSE ATTENTION NOT TO DROP THE CALIBRATED PADS INTO THE ENGINE.

- After replacing the pad(s), install the intake shaft (3) on the timing chain, so that the sprocket and the chain marks coincide, then position it in its seat on the head.

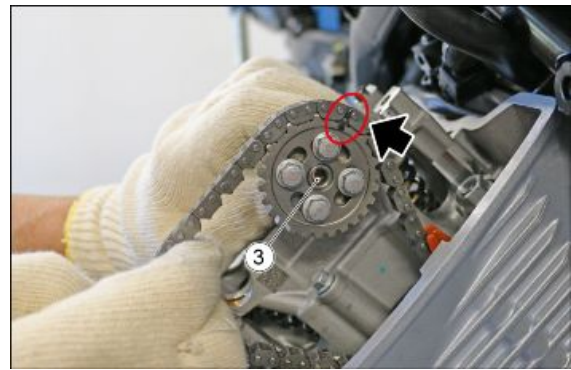

- Install the exhaust shaft (4) on the timing chain, by aligning the references the sprocket and chain, then place it in its seating on the head.

CAUTION

WHEN INSTALLING THE EXHAUST SHAFT, TAKE CARE NOT TO DROP THE INTAKE SHAFT.

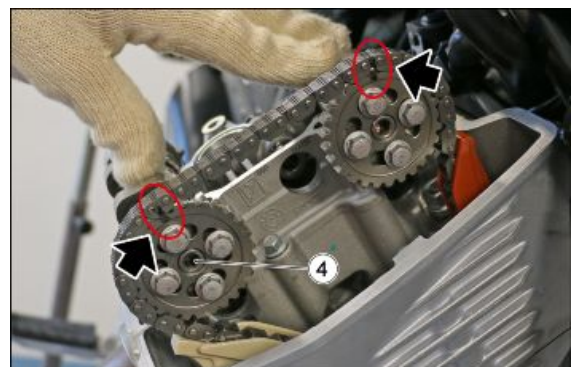

- Refit the special tool (1) back into the intake and exhaust camshafts.



- While holding the camshafts in position, install the upper mounting (2).

NOTE

WHEN REMOUNTING THE PUMP, REPLACE THE "O-RINGS"

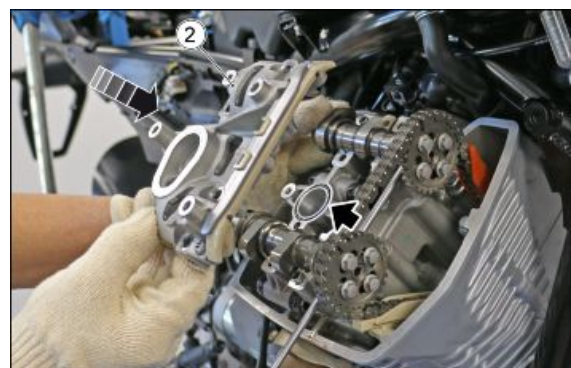

- Tighten the fixing screws to the specified torque, following the sequence A-B-C-D-E-F-G-H- I.

Locking torques (N*m)

Camshaft support screw 11-13 Nm (8.11 - 9.59 lbf ft)

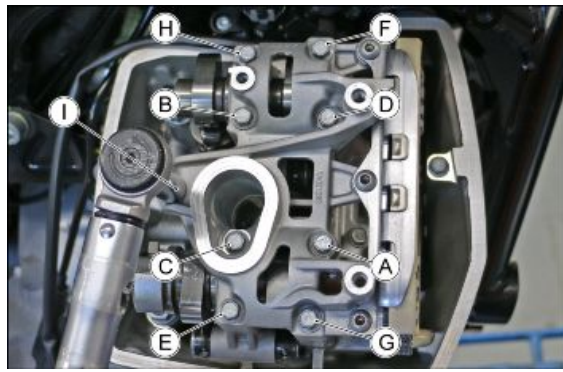

NOTE

The screw (6) in the hole of the spark plug has a washer, while the screw (7) is the single shorter screw compared to the others.



- Remove the special tool (1) from the camshafts.

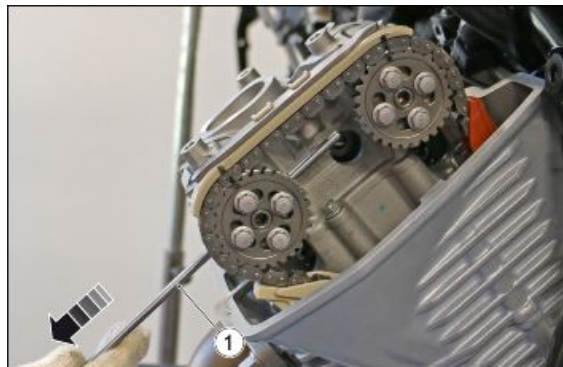

- Remove the pin from the pinion of the crankshaft.
- Refit the cover valves, spark plug, timing system cover and the radiator.
- Restore the water level in the radiator and in the expansion tank.



LH HEAD

To adjust the valves of the LH head, follow the procedures for the RH head but with the difference of:

- Turn the engine COUNTER-CLOCK-WISE and bring the LH piston to Top Dead Centre.

NOTE

THE HOLE ON THE PINION MARKED "PMS SX" MUST BE ALIGNED WITH THE HOLE ON THE CRANKCASE.

- Make sure that the lobes of the camshafts are facing up and convergent.

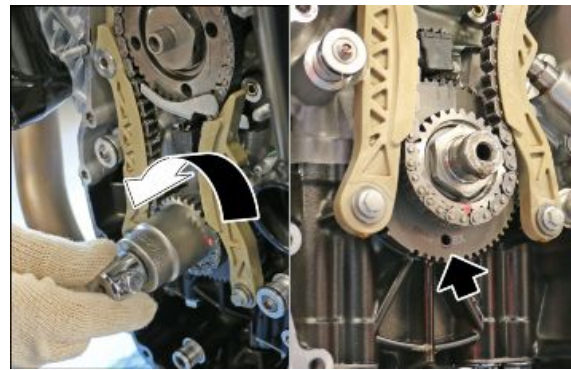

Cooling system

Level check

- Shut off the engine and wait until it cools off.
- Keep the vehicle upright with both wheels on a flat surface.
- Looking from right side of the vehicle, behind the steering headstock, make sure that the fluid level in the expansion tank is between the "MIN" (minimum) and "MAX" (maximum) marks.



WARNING

CARRY OUT THE CHECK AND TOP UP THE REFRIGERANT LIQUID WITH THE ENGINE SWITCHED OFF AND COLD.

Top-up

- Remove the expansion tank cap.
- Top up with the recommended fluid, to reach a level between the notch "MIN" and "MAX" of the expansion tank, visible from the right side of the vehicle behind the steering headstock.



Braking system

Level check

FRONT BRAKE

- Rest the vehicle on its stand.
- Turn the handlebar so that the fluid is at the same level as the plug.
- Make sure that the fluid level in the reservoir is above the "MIN" reference mark:

MIN = minimum level

MAX = maximum level

If the fluid does not reach at least the "**MIN**" reference mark:

- Check the state of wear of the discs and of the brake pads.
- If the pads and / or the discs do not need replacing, check that the lack of fluid is not due to leaks in the braking system.
- When the system is in good condition, top up the brake fluid.

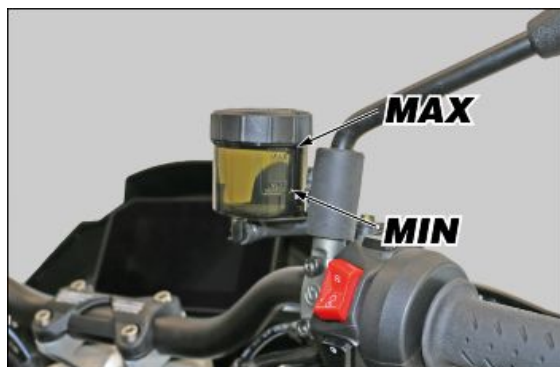

REAR BRAKE

- Keep the vehicle upright so that the fluid in the reservoir is at the same level as the plug.
- Make sure that the fluid level in the reservoir is above the "MIN" reference mark:



MIN = minimum level

MAX = maximum level

If the fluid does not reach at least the "**MIN**" reference mark:

- Check the state of wear of the brake disc and of the brake pads.
- If the pads and / or the disc do not need replacing, check that the lack of fluid is not due to leaks in the braking system.
- When the system is in good condition, top up the brake fluid.

Top-up



RISK OF BRAKE FLUID SPILLING. DO NOT OPERATE THE BRAKE LEVER IF THE BRAKE FLUID RESERVOIR CAP IS LOOSE OR HAS BEEN REMOVED.

CAUTION



AVOID PROLONGED AIR EXPOSURE OF THE BRAKE FLUID. BRAKE FLUID IS HYGROSCOPIC AND ABSORBS MOISTURE WHEN IN CONTACT WITH AIR. LEAVE THE BRAKE FLUID RESERVOIR OPEN ONLY FOR THE TIME NEEDED TO COMPLETE THE TOPPING-UP PROCEDURE.



TO AVOID SPILLING FLUID WHILE TOPPING UP, KEEP THE LEVEL OF THE FLUID IN THE RESERVOIR PARALLEL WITH THE EDGE OF THE RESERVOIR ITSELF (IN HORIZONTAL POSITION). DO NOT ADD ADDITIVES OR OTHER SUBSTANCES TO THE FLUID. FUNNELS OR ANY OTHER IMPLEMENTS USED MUST BE PERFECTLY CLEAN.



BRAKE FLUID IS HIGHLY CORROSIVE. AVOID CONTACT WITH THE SKIN, EYES AND PARTS OF THE MOTORCYCLE.

WHEN TOPPING UP, PROTECT PARTS OF THE MOTORCYCLE IN THE VICINITY OF THE RESERVOIR WITH ABSORBENT MATERIAL.

Recommended products

DOT 4 brake fluid Synthetic brake fluid.

SAE J 1703; FMVSS 116; ISO 4925; CUNA NC 956 DOT4

Front braking system

- Use a short Philips screwdriver, unscrew the screws (1) of the front braking system fluid tank (2).

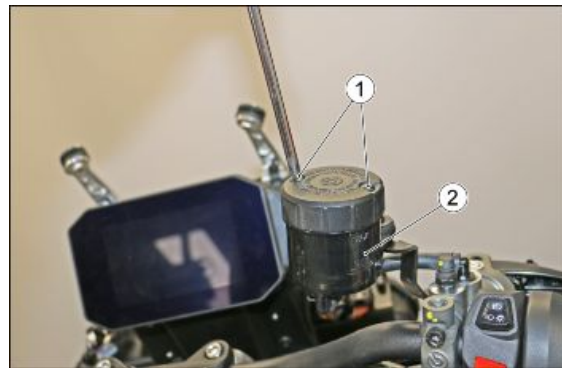

- Lift and remove the cover (3) and screws (1) as well.

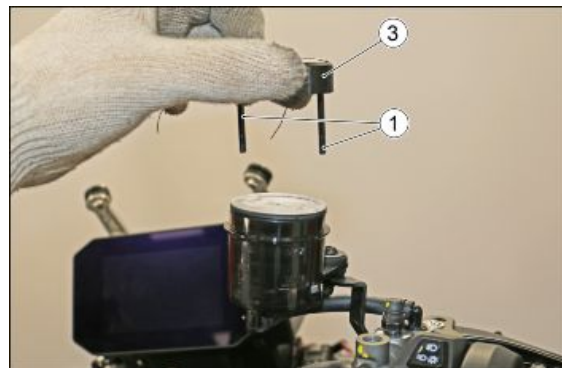

- Remove the gasket (4).
- Top up the reservoir (2) with recommended brake fluid to above the minimum level marking "MIN".

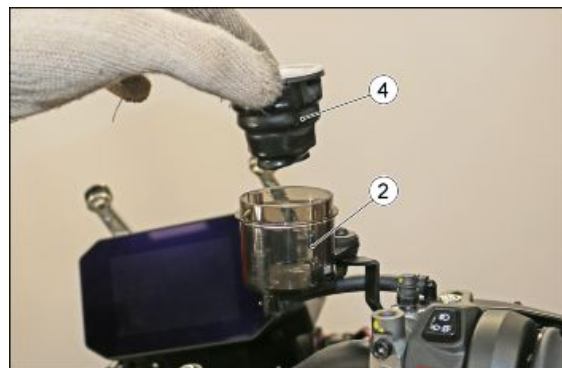

CAUTION



ONLY FILL TO THE "MAX" LEVEL AFTER FITTING NEW BRAKE PADS. DO NOT FILL TO THE "MAX" LEVEL WITH WORN PADS, AS THIS WILL CAUSE FLUID TO ESCAPE WHEN REPLACING BRAKE PADS. CHECK BRAKING EFFICIENCY.

IF THE DEAD ZONE OF THE BRAKE PEDAL OR BRAKE LEVER IS TOO LONG, OR IN CASE OF FLUID LOSS, IT MAY BE NECESSARY TO BLEED THE AIR TRAPPED IN THE SYSTEM.

Rear braking system

- Unscrew the cap (5) and remove together with the gasket (6).
- Top up the reservoir (7) with recommended brake fluid to above the minimum level marking "MIN".

CAUTION

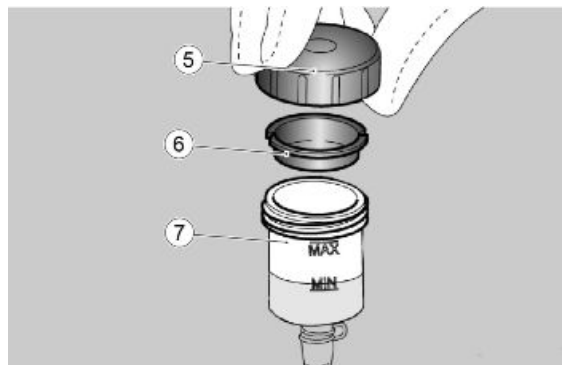

ONLY FILL TO THE "MAX" LEVEL AFTER FITTING NEW BRAKE PADS. DO NOT FILL TO THE "MAX" LEVEL WITH WORN PADS, AS THIS WILL CAUSE FLUID TO ESCAPE WHEN REPLACING BRAKE PADS.

CHECK BRAKING EFFICIENCY.

IF THE DEAD ZONE OF THE BRAKE PEDAL OR BRAKE LEVER IS TOO LONG, OR IN CASE OF FLUID LOSS, IT MAY BE NECESSARY TO BLEED THE AIR TRAPPED IN THE SYSTEM.

Clutch system

Regolazione leva frizione

Perform the clutch adjustment when the engine stops or the vehicle tends to drive forward with the clutch lever actuated and the gear engaged, or if the clutch "slips", causing the acceleration to delay in relation to the number of engine revolutions. It is possible to adjust the distance between the end of the lever (1) and the grip (2), turning the adjuster (3).

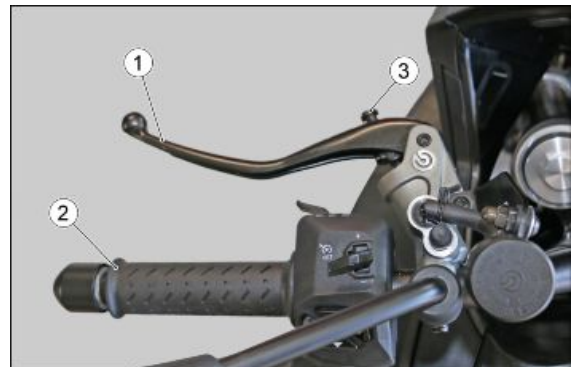

- Push the control lever (1) forwards and turn the adjuster (3) until the lever (1) is at the desired distance.
- Turning the adjuster clockwise moves the lever (1) away from the handle (2).

In the event that the adjustment of the lever is not sufficient, check that there is no air in the hydraulic circuit or loss along the same; refer to the section "braking system" for more information.

Headlight adjustment

NOTE

IN COMPLIANCE WITH LOCAL LEGISLATION, SPECIFIC PROCEDURES MUST BE FOLLOWED WHEN ALIGNING THE LIGHTS.

To quickly check if the headlamp is aimed correctly, place the vehicle on a level surface 10 m (32.8 ft) from a vertical wall. Turn on the low beam light, sit on the vehicle and check that the light beam projected to the wall is a little below the horizontal straight line of the headlight (about 9/10 of the total height).

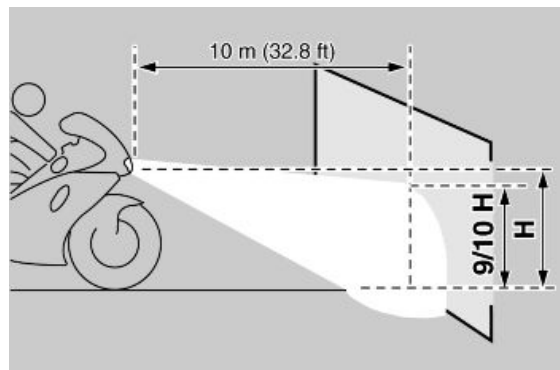

To carry out vertical adjustment of the light beam:

- Place the vehicle in a vertical position;
- Adjust the adjusting screws (1) and (2), located under the instrument panel, to adjust the (1) left and (2) right low beam headlamps. Turning the screw clockwise lowers the headlamp, and counterclockwise raises the headlamp.
- Using a Phillips screwdriver, turn the adjustment screw that can be reached from under the top fairing to adjust the high beam headlight. Turning the screw clockwise lowers the headlamp, and counterclockwise raises the headlamp.

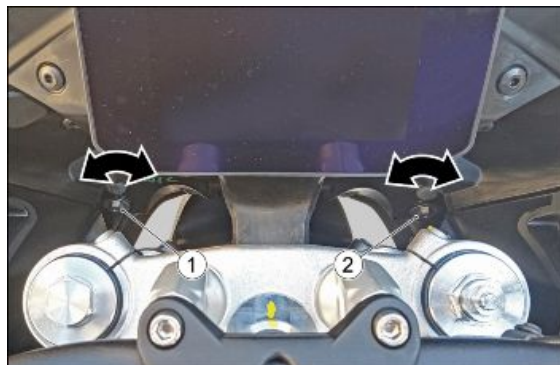

NOTE

ONCE THE ADJUSTMENTS ARE FINISHED, CHECK THE VERTICAL ORIENTATION OF THE LIGHT BEAM.

Anti-evaporation system

Removing system components

NOTE

IF THE FILTERING EFFECTIVENESS IS COMPROMISED, REPLACE THE COMPLETE CANISTER.

- First remove the fuel tank.
- Disconnect the connector (1) from the SAS valve.



- Disconnect the connector (2) from the coolant temperature sensor on the left cylinder.



- Once the connectors are disconnected, release the wiring harness from its fitting on the canister.

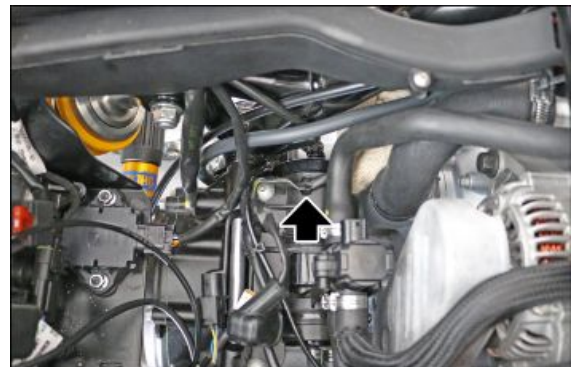

- Release the wiring harnesses from the retainers on the canister indicated in the figure.

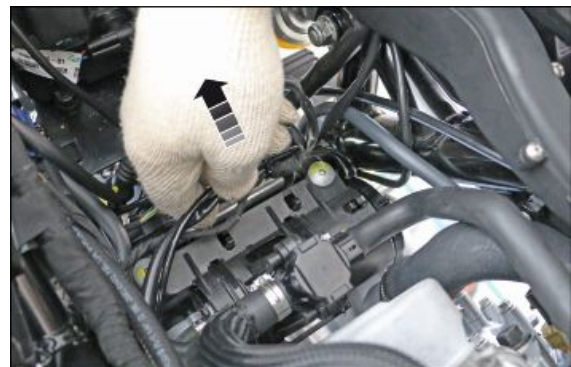

- Remove the two screws fixing the canister to the frame.

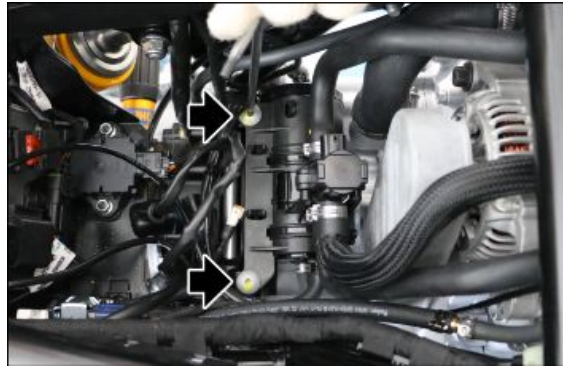

- Lift the canister to allow easy access to the SAS valve lines.
- Open the clamps and remove the two pipes (3) on the right side of the SAS valve.



- Open the clamp and remove the pipe (4) from the canister.



- Open the clamp and remove the pipe (5) from the canister.

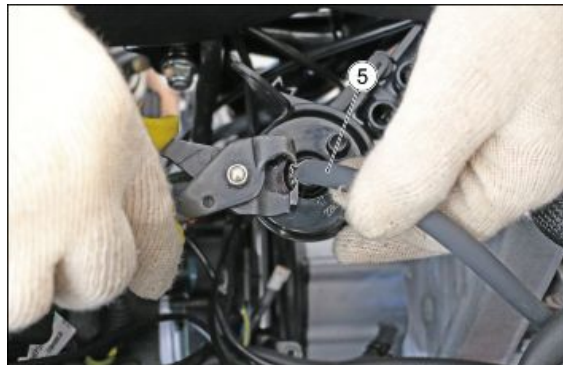

- Open the clamp and remove the breather pipe (6) from the canister.



- Open the clamp and remove the pipe (7) from the left side of the SAS valve.



- Remove the canister from the vehicle.



- If it is necessary to replace the safety valve (8), open the spring clamps (9), disconnect the pipes (10) and proceed with the replacement. During refitting, make sure to observe the direction of the valve (8).

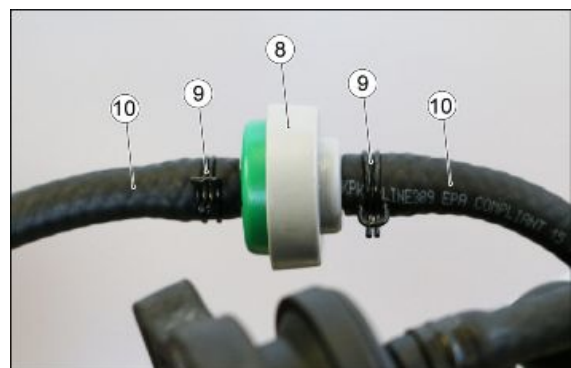

INDEX OF TOPICS

ELECTRICAL SYSTEM

ELE SYS

Alternator belt removal

- First remove the fuel tank and the canister.
- Remove the three fixing screws shown in the figure.

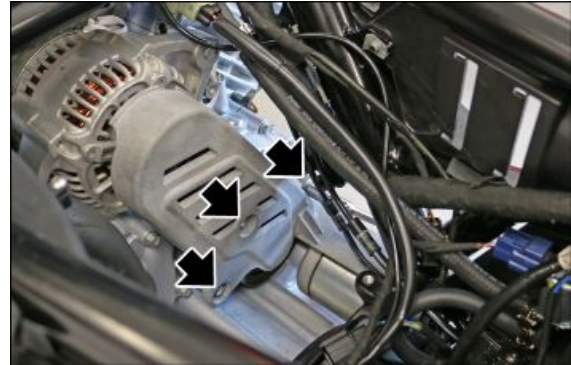

- Remove the cover of the belt from the vehicle.



- Remove the three fixing screws shown in the figure.

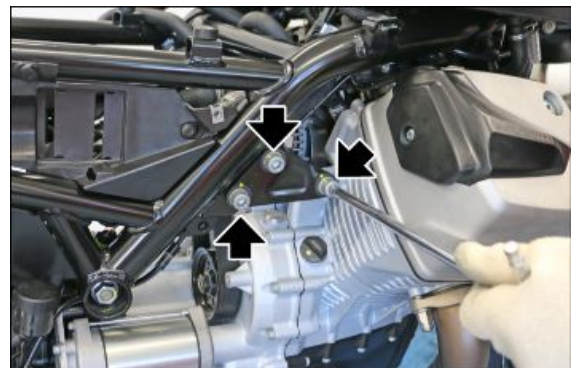

- Remove the right head support bracket.



- Loosen the lock nut of the set screw.



- Tighten the adjuster screw until it stops with the lock nut.

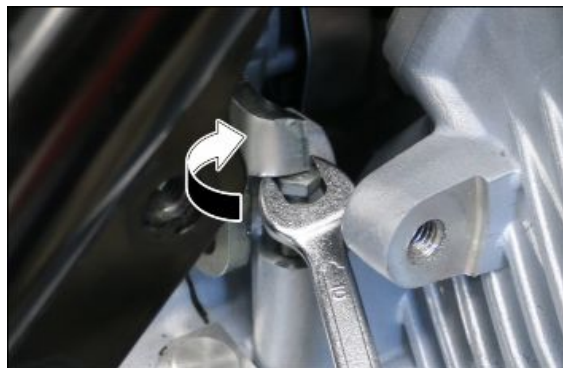

- Remove the fixing screw of the adjustment bracket.



- Unscrew almost completely the left fixing screw of the alternator, but DO NOT remove it.



- Press downwards the alternator so as to release the belt tension.
- Remove the belt from the alternator pulley then remove it from the vehicle.



Alternator belt installation

- Install the belt on the engine pulley, then fit it on the alternator pulley.



NOTE

Fit the belt with the writing aligned as shown in the figure.



- Screw in the left-hand alternator fixing screw, without tightening it.



- Screw in the fixing screw of the adjusting bracket, without tightening it.



- Unscrew the adjusting screw to temporarily tension the belt.
- Follow the belt tensioning procedure described below, not including parts related to component removal.



Alternator belt tensioning

- First remove the fuel tank and the canister.
- Remove the three fixing screws shown in the figure.

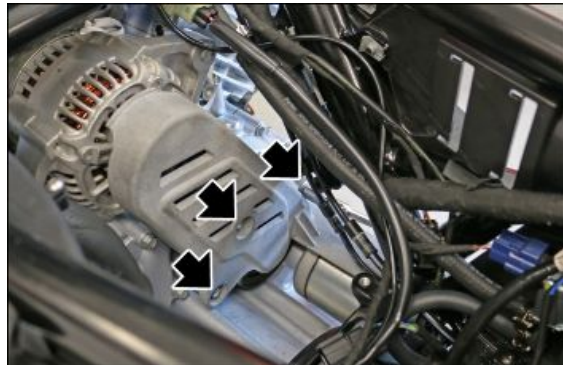

- Remove the cover of the belt from the vehicle.



- Remove the three fixing screws shown in the figure.

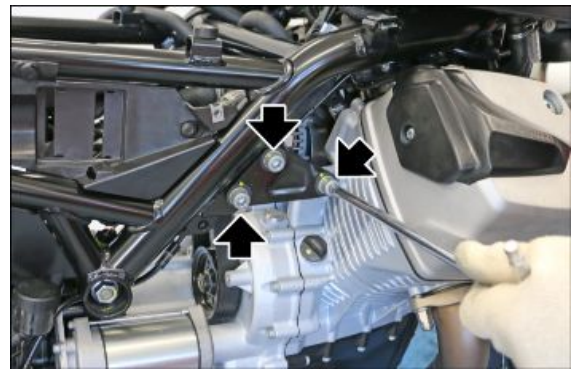

- Remove the right head support bracket.



- Using a digital frequency meter, measure the belt tensioning frequency by vibrating it with your finger.



Characteristic
Alternator belt frequency
180 Hz

- Loosen the screws (1) and (2) fastening the alternator.

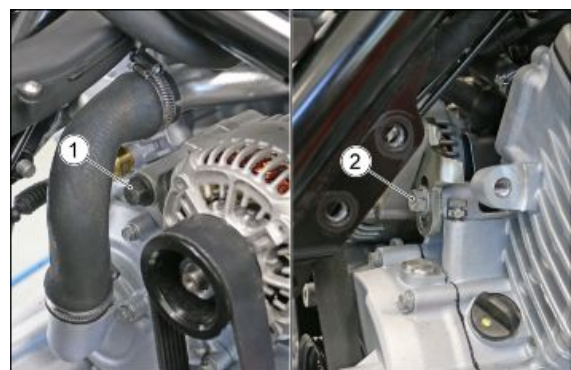

- Loosen the lock nut of the set screw.



- Act on the adjuster screw, screwing it in to decrease the tensioning frequency or unscrewing it to increase it.

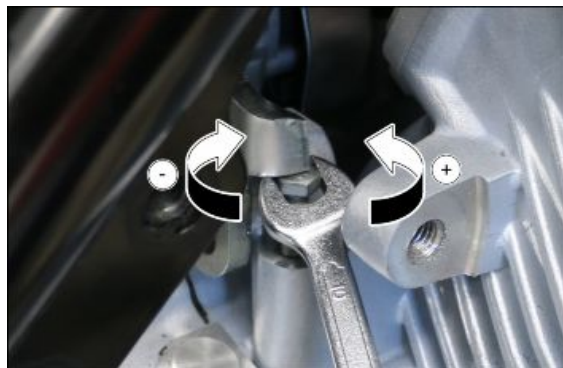

- Tighten the fixing screws (1) and (2) of the alternator to the specified torque.

WARNING

It is essential to tighten the fixing screws to measure the tensioning frequency correctly.

Locking torques (N*m)

Fixing screw (1) 45 - 50 Nm (33.19 - 36.88 lb ft) **Fixing screw (2)** 20 - 24 Nm (14.75 - 17.70 lb ft)

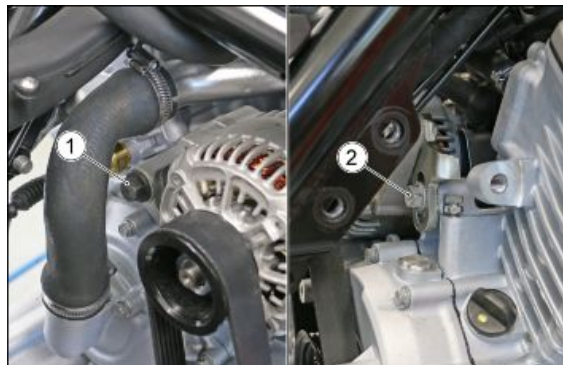

- Measure the tensioning frequency of the alternator belt again.

Characteristic

Alternator belt frequency

180 Hz



- If the tension is correct, tighten the lock nut of the adjuster screw.
- Otherwise, repeat the operations for the belt tensioning.



- When the correct belt tension frequency is reached, install the RH head support bracket.



- Install the three fixing screws and tighten them to the specified torque.

Locking torques (N*m)

Head mounting bracket fixing screw 50 ± 7.5 Nm
(36.88 ± 5.53 lb ft)

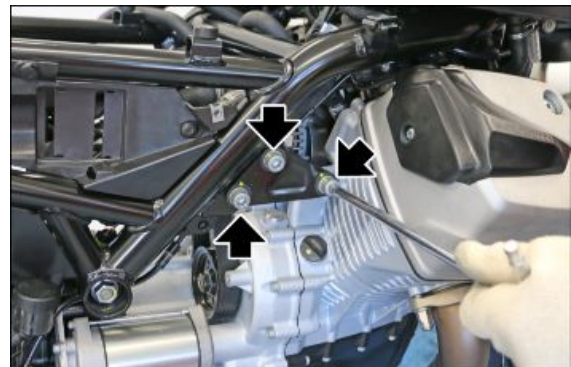

- Fit the cover of the belt on alternator.



- Tighten the three fixing screws of the alternator belt cover.
- Refit the canister and the fuel tank on the vehicle.

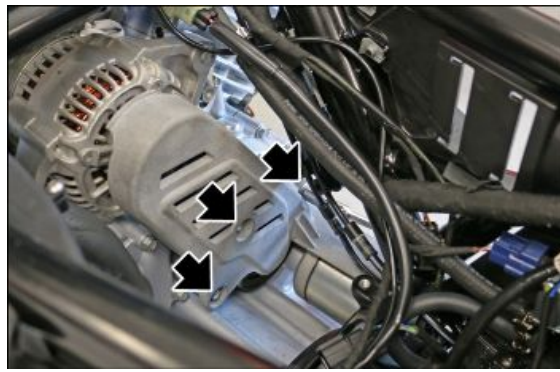

Components arrangement

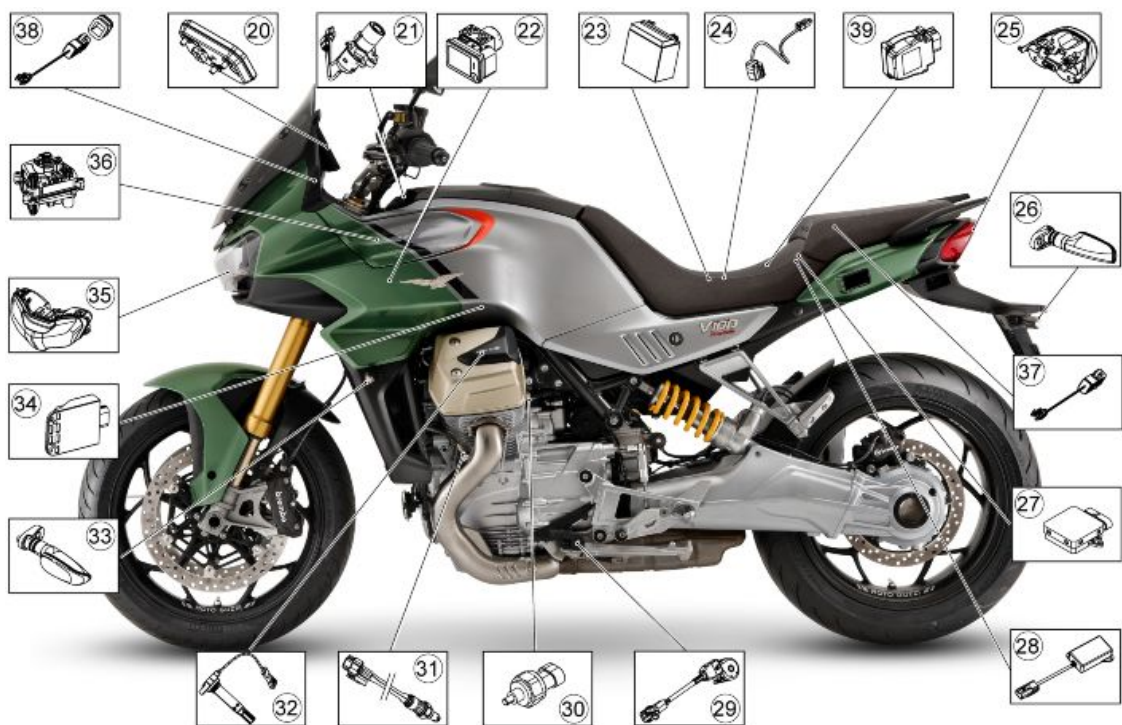

**KEY:**

1. ECU
2. Starter relay and main fuses;
3. Secondary fuses;
4. Fuel pump;
5. Fuel level sensor;
6. Right-hand aerodynamic flap actuator;
7. Adjustable top fairing actuator;
8. Coolant temperature sensor;
9. Front right turn indicator;
10. Front ABS sensor;
11. Horn;
12. Right Lambda probe;
13. Right pipette/coil;
14. Starter motor;
15. PURGE valve;
16. IMU ECU;
17. Rear right turn indicator;
18. Licence plate lamp;
19. Alternator;
20. TFT instrument cluster;
21. Ignition switch assembly;

- 22. ABS Modulator;
- 23. Battery;
- 24. OBD5 port;
- 25. Rear light cluster;
- 26. Rear left turn indicator;
- 27. TPMS ECU;
- 28. GMP ECU;
- 29. Stand sensor;
- 30. Engine oil temperature sensor;
- 31. Left lambda probe;
- 32. Left pipette/coil;
- 33. Front left turn indicator;
- 34. Voltage regulator;
- 35. Front light cluster;
- 36. Left-hand aerofoil flap actuator;
- 37. USB port
- 38. USB socket (if provided);
- 39. Ohlins suspension ECU (V100 Mandello S).

Checks and inspections

GENERAL NOTIONS FOR TROUBLESHOOTING ELECTRICAL FAULTS

THE SECTIONS RELATIVE TO THE ELECTRICAL SYSTEM CONTAIN DRAWINGS OF CONNECTORS; NOTE THAT THE DRAWING ALWAYS DEPICT THE CONNECTOR/COMPONENT VIEWED FROM THE WIRING HARNESS SIDE, I.E. FROM THE SIDE ON WHICH THE CABLES LEADING FROM THE MAIN WIRING HARNESS ENTER THE CONNECTOR/COMPONENT.

CAUTION

BEFORE STARTING ANY TROUBLESHOOTING PROCEDURES ON THE VEHICLE, CHECK THAT THE BATTERY VOLTAGE IS ABOVE 12V.

CONNECTOR CHECK PROCEDURE

The procedure includes the following checks:

1. Observation and check of the connector correct position on the component or on the coupling connector, making sure that the locking catch is released.
2. Observation of the terminals on the connector: no rust marks or dirt should be present and it is important to check terminal correct positioning on

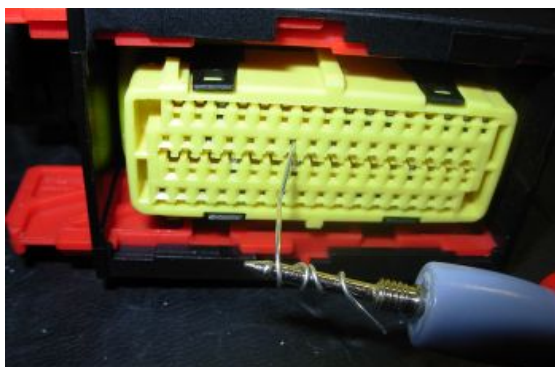

the connector (i.e., all terminals aligned at the same depth) and terminal integrity (i.e., that terminals are not loose, open/bent, etc.). For connectors whose terminals are not visible (e.g. Marelli control unit) use a metal cable of suitable diameter and introduce it carefully in the connector slot at the same depth as for the other terminals of the connector.

CAUTION

IN THE CASE OF SPORADIC FAULTS, MOVE OR WIGGLE THE RELATIVE WIRING HARNESS SLIGHTLY WHILE PERFORMING EACH OF THE CHECKS INDICATED FOR TROUBLESHOOTING.

3. Pull cables gently from the back of the connector to check that the terminals are fitted correctly on the connector and that the wires are fastened correctly to the terminals.

Checking electrical CONTINUITY

Purpose of check: the purpose of this check is ensure that there are no interruptions or excess resistance (due to corroded terminals, for example) in the circuit under inspection.

Tester: set the tester selector to the "continuity" symbol and place the probes of the tested at the two ends of the circuit: Normally, the tester will sound an audible signal to confirm continuity in the section of circuit tested; Continuity may also be tested by setting the tester selector to the "Ohm" symbol and checking that the resistance in the circuit is zero or of a few tenths of an Ohm.

WARNING: THE CIRCUIT MUST BE UNPOWERED DURING THIS TEST. IF THE CIRCUIT IS POWERED, THE RESULTS OF THIS TEST ARE MEANINGLESS.

Checking GROUND CONNECTION

Purpose of check: the purpose of this check is to verify that a cable or circuit is correctly connected to the ground (-) of the vehicle.

Tester: set the tester selector to the "continuity" symbol and place one of the tester probes on the vehicle ground point (or on the battery negative pole) and the other probe on the cable under inspection: Normally, the tester will sound an audible signal to confirm continuity in the section of circuit tested. Continuity may also be tested by setting the tester selector to the "Ohm" symbol and checking that the resistance in the circuit is zero or of a few tenths of an Ohm.

IMPORTANT: WHERE GROUND IS PROVIDED BY THE ECU, CHECK THAT THE ECU IS EFFECTIVELY PROVIDING THE GROUND CONNECTION FOR THE CIRCUIT DURING THE TEST.

Checking VOLTAGE

Purpose of check: the purpose of this check is to determine if a cable is carrying voltage, in other terms, to verify whether it powered by the battery or ECU.

Tester: set the tester selector to the "DC voltage" symbol and place the red tester probe on the cable under inspection and the black tester probe on the vehicle ground point (or on the battery negative pole).

CAUTION

IN THE CASE OF SPORADIC FAULTS, MOVE OR WIGGLE THE RELATIVE WIRING HARNESS SLIGHTLY WHILE PERFORMING EACH OF THE CHECKS INDICATED FOR TROUBLESHOOTING.

Immobiliser

The vehicle is equipped with an electronic engine disabling system that is activated automatically when the ignition key is removed. Each key in the grip has an electronic device - transponder - which modulates the radio frequency signal emitted by a special aerial inside the switch when the vehicle is started. The modulated signal is the "password" by which the appropriate central unit recognises the key and only after this occurs, it allows the engine start-up.

The vehicle is delivered to the customer with two pre-programmed keys. The instrument cluster accepts a maximum of four keys at the same time. Approximately ten seconds after the key is set to ON, the instrument cluster requests a personal five-digit code to be entered.

On the leftmost value of the display, a variable value is shown that can be modified from 0 to 9, by using the MODE selector. Press the centre of the MODE selector to confirm each of the five digits. Once confirmed, the display shows the code in a fixed manner, this is so the user can check the code that has been entered. To remove the screen showing the code that has been entered, carry out a KEY OFF- KEY ON cycle. In the future you can always change the last code entered. This request message is no longer displayed once the personal code is entered.

It is important to remember the personal code because:

- the vehicle can be started if the immobilizer system is faulty
- the instrument cluster need not be replaced should the ignition switch be changed
- new keys can be programmed

NOTE

IF THE PERSONA CODE IS NOT MEMORISED AND THE VEHICLE IS USED, THE MESSAGE DISAPPEARS AFTER 10 SECONDS BUT REAPPEARS WITH EACH KEY ON.

NOTE

THE FACTORY SET CODE IS COMPOSED OF FIVE ZEROES.

All the functions for changing, storing or resetting the immobilizer codes can be carried out by the dealer, whereas some of the instrument cluster settings can also be carried out by the customer.

With the key set to "KEY OFF" the general alarm warning light flashes to indicate activation of the locking system.



If there is an immobilizer failure at ignition, the instrument cluster requests you to enter a user code. If the code is entered correctly, the instrument cluster signals the failure by displaying the word SERVICE and the red general warning light turns on.

Once the code has been correctly entered, the error will be displayed on the screen, and you can still start the motorcycle.

CAUTION

PRESSING OR MOVING ANY CONTROL ON THE LEFT SWITCH CLUSTER, IT IS POSSIBLE TO REMOVE THE ERROR NOTIFICATION SCREEN, BUT THE SCREEN WILL BE VISIBLE AGAIN AFTER ABOUT 10 SECONDS.



Change user code (Change user code)

This function may be used to modify the existing code (you must be in possession of the code itself in order to do this). The user code enables engine start even in the event of an immobiliser system fault. The user code is set by default as five zeros (00000) on a new vehicle, and the message "INSERT CODE" is shown on the display for ten seconds.

This function allows you to change the code itself and remove this message.

On the value to the leftmost of the display a value from 0 to 9 will be shown (which can be modified by moving the MODE selector upward or downward). Press the centre of the "MODE" selector briefly to confirm the selection. Repeat the operation for all the digits. Once the code is confirmed, the new code is shown steadily on the display to let the user verify that the code has been entered correctly. Turn the ignition off and then on again to unlock the instrument cluster. The last code set may be modified again in future. Access the setting mode again, enter the last user code used (OLD CODE), then enter a new user code (NEW CODE) as described previously.



Code recovery (Code recovery)

This function must be used should it be necessary to change the user code when the user no longer remembers the current code. Both keys stored in the vehicle memory are needed to access this function.

When the function is activated, by pressing briefly on the middle of the MODE selector, the screen "INSERT KEY 1" is displayed to signal the recognition request of the first key. Insert the key. If the correct key is recognised within twenty seconds, the message "INSERT KEY 2" is shown on the display. Insert the second key. If the second key is also recognised within twenty seconds, the instrument cluster resets the user code to the default code (five zeros - 00000). Enter the new user code following the "CHANGE USER CODE" procedure.



IMMOBILIZER ANTENNA

Function

detects the transponder code in the key and sends it to the instrument cluster

Level in electrical circuit diagram:

Immobilizer

Position:

- on the vehicle: in the instrument cluster
- connector: two-way, grey, below the right side steering sleeve

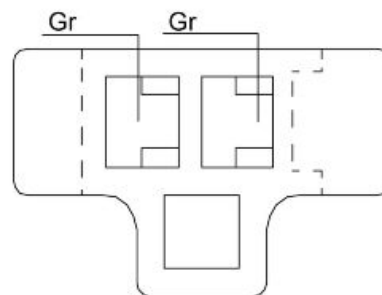

Electrical specifications

- 14 Ohm

Pin out

not significant

Diagnostic tool - Electrical errors

The instrument cluster errors are detected by means of the diagnostic tool. It is therefore necessary to connect it to the vehicle.

Error code B0003 (ALARM IMMO B0003)

Error cause

- Occurs, when the transponder is working, but it is not within the recognised ones.

Identification

- General alarm warning continuously on (red) and indication "ALARM IMMO B0003" on the display

Troubleshooting

- Store the new key

Error code B0004 (ALARM IMMO B0004)

Error cause

- Occurs, when the key has no transponder or the transponder is damaged

Identification

- General alarm warning continuously on (red) and indication "ALARM IMMO B0004" on the display

Troubleshooting

- Replace the key and store it

Error code B0005 (ALARM IMMO B0005)

Error cause

- Occurs when an electric interruption or a ground short circuit or voltage to the circuit have been detected.

Identification

- General alarm warning continuously on (red) and indication "ALARM IMMO B0005" on the display

Troubleshooting

- Check the sensor connector on the wiring harness and the instrument panel connector. Check that the antenna is connected, if OK remove it and check the continuity of the antenna between the PIN of the connector (resistance between 10 - 100 Ohm), if not OK replace the sensor; if OK reconnect the connector to the antenna and check from the wiring harness side that there is continuity between the two PIN (resistance between 10-100 Ohm), if not OK restore the wiring harness; if OK check continuity between the two PIN 2 and 3 of the instrument panel, if not OK replace the instrument panel.

Error code B0006 (ALARM IMMO B0006)

Error cause

- Occurs when a fault in the instrument panel has been detected

Identification

- General alarm warning continuously on (red) and indication "ALARM IMMO B0006"

Troubleshooting

- Replace the instrument cluster

Error code B0007 (ALARM 1 KEY STORED)Error cause

- Occurs when the number of stored keys is less than two

Identification

- General alarm warning continuously on (red) and indication "ALARM 1 KEY STORED" on the display

Troubleshooting

- Store the two keys again

System not programmed**Storing new keys****NOTE**

REGARDLESS OF THE LANGUAGE SET IN THE DASHBOARD FUNCTIONS, THE KEY PROGRAMMING PROCEDURE CAN ONLY BE VIEWED IN ENGLISH.

- To carry out the one or more key programming procedures, up to a maximum of four, you must connect the motorcycle to the diagnostic tool.
- Turn key to "ON" and insert the USER CODE where required.
- Carry out the self-diagnostic of the dashboard and enter the "SETTINGS" section by clicking on "RESET KEYS".
- At this point, a screen with a warning message will be visible. Press "OK" and start programming the keys.

**NOTE**

IF THE IMMOBILIZER ANTENNA IS DISCONNECTED, YOU WILL NOT BE ABLE TO START KEY PROGRAMMING.

- Enter the USER CODE to continue.
- If the code entered is correct, the first key is stored.



- At this point, on the digital display of the motorcycle, after the automatic restart of the dynamic presentation screen, a message will appear with a countdown of 20 seconds to insert the second key to be programmed.
- Set key to "OFF", insert the second key and set to "ON".

CAUTION

IF YOU DO NOT HAVE A SECOND KEY OR YOU DON'T WANT TO STORE ONE, THE DIAGNOSTIC TOOL WILL SHOW AN ERROR SAYING "1 KEY STORED"

- The second key is stored and you will be asked to enter the third key (if you have one). The same operation will be repeated to store the fourth key.
- To complete AND end the memorisation procedure, set key to "OFF".
- You should then test the correct functioning of all keys stored.

**Maintenance icon reset**

The system displays the function as follows:

- After the maintenance interval thresholds are exceeded (excepting the first), an icon with the adjustable wrench is shown on the digital display.

To reset Service proceed as follows:

- Connect the diagnostic tool;
- Select the concerned model;
- Enter in the "INSTRUMENT CLUSTER" section;
- Select "SELF-DIAGNOSTIC";
- Select "ACTIVATIONS";



- Enable the command "SERVICE RE-SET".

Infotainment

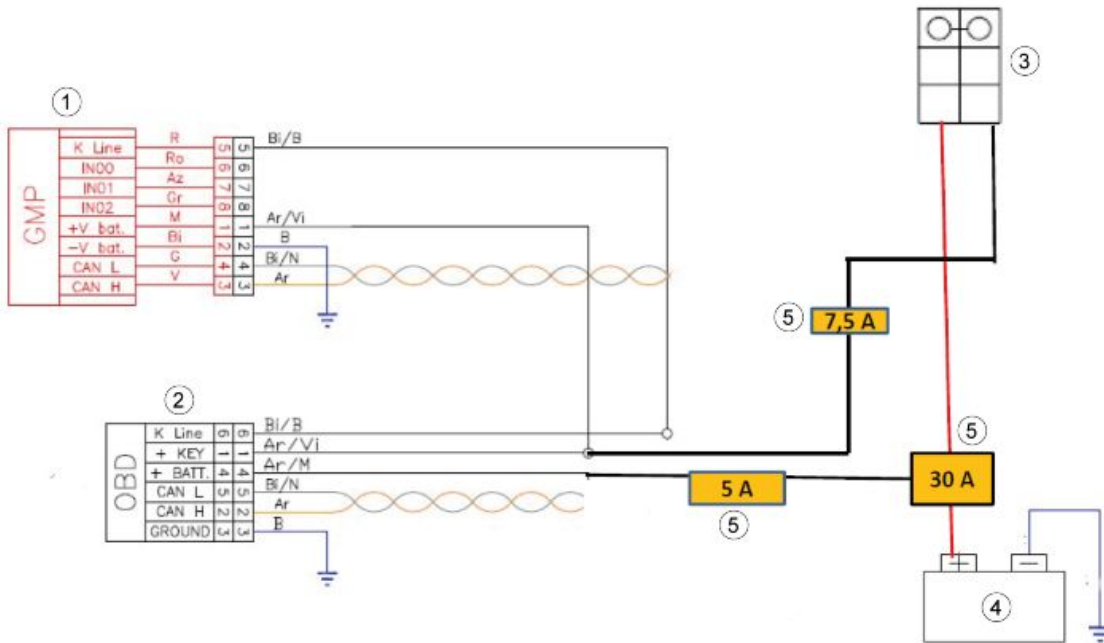

INFOTAINMENT

Key:

1. GMP ECU
2. OBD ECU
3. Ignition switch
4. Battery
5. Fuse

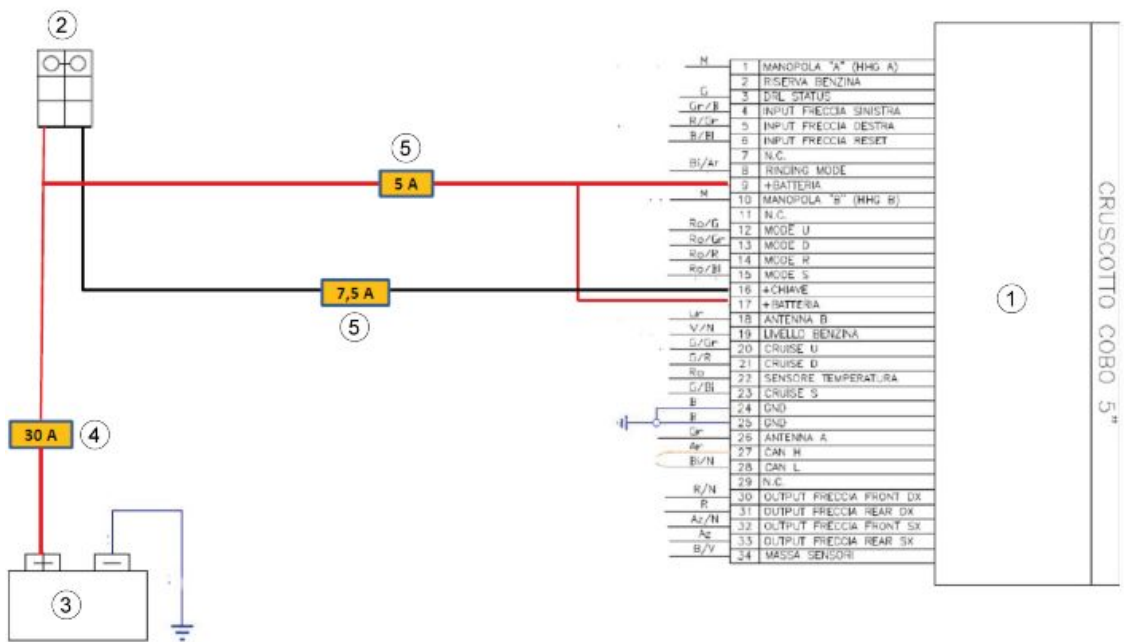

INSTRUMENT CLUSTER

Key:

- 1. TFT instrument cluster
- 2. Ignition switch
- 3. Battery
- 4. Main fuse
- 5. Fuse

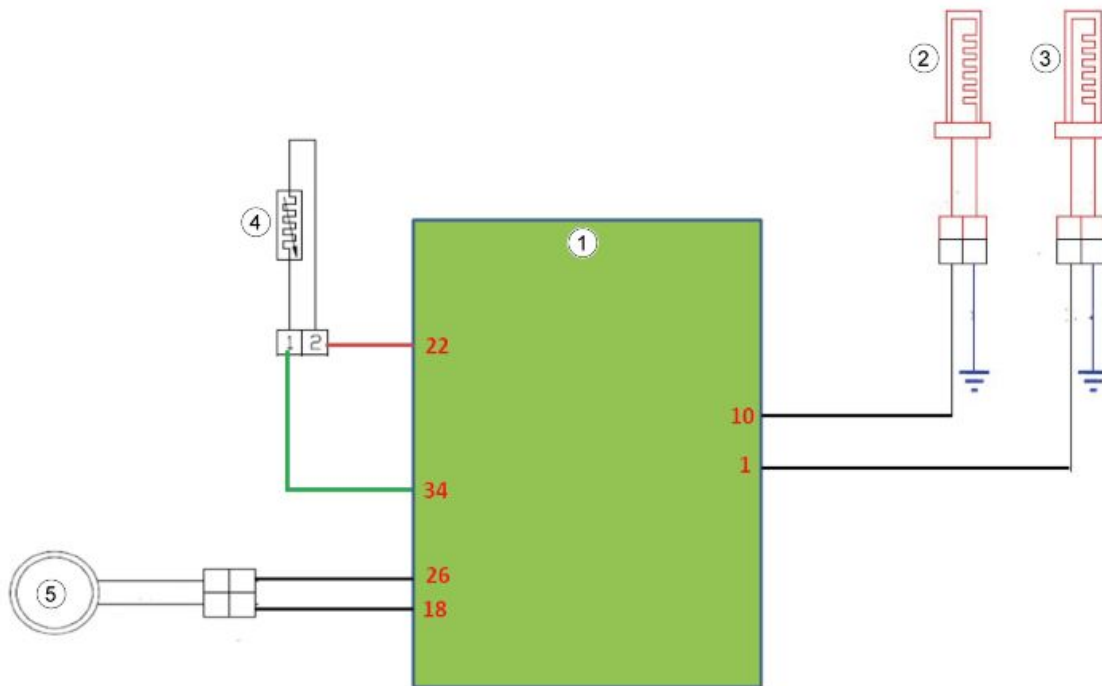

HEATED HAND GRIPS - Only for V100 Mandello S

Key:

- 1. Instrument cluster
- 2. Right hand grip
- 3. Left hand grip
- 4. air temperature sensor
- 5. Immobilizer antenna

Battery recharge circuit

Key:

- (1) Generator.
- (2) Secondary fuse.
 - Rear daylight running light
 - Horn
 - Licence plate lamp
- (3) Sense connection.
- (4) Ignition switch
- (5) Main fuse .
- (6) Battery.

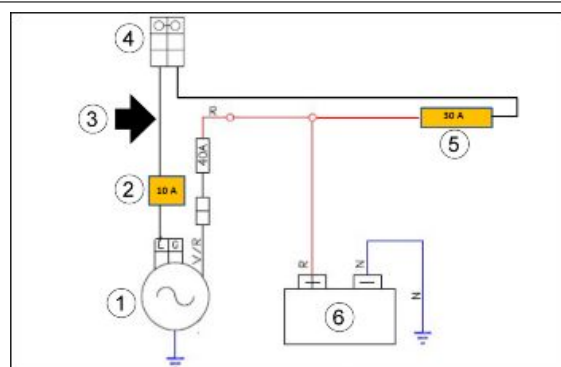

The generator starts to recharge the battery only with:

- Ignition switch set to ON,
- Battery voltage below 14.8 Volt,
- If voltage of at least 2 Volts is applied to the Sense connection.

CAUTION

Do not leave the vehicle with the engine off and the ignition key to "ON". The sophisticated on-board instruments have a high current draw which, if left on with the engine switched off, will discharge the battery in a short time.

Recharge system voltage check

The following tools are required to test the functionality of the charging system:

1. Ammeter clamp.
2. Voltmeter.
3. Fuse interrupted with a wire bridging between the two pins.

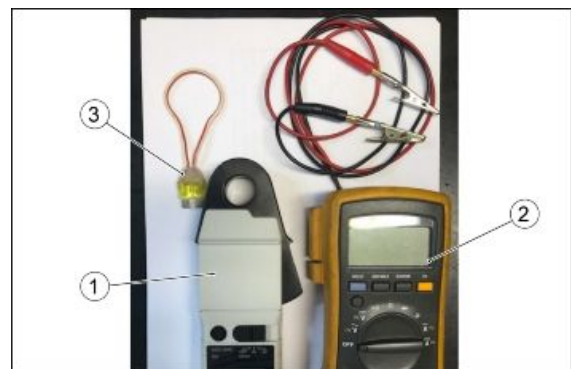

- Remove the rider saddle and the battery cover.
- Remove the 40 A main fuse.



- Restore the continuity of the circuit inserting, in the fuse holder, the previously prepared fuse (3).

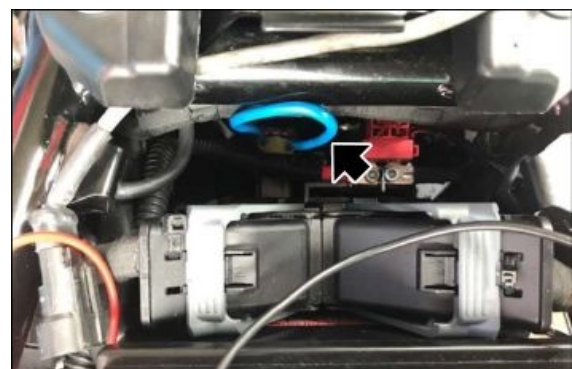

- Position the ammeter clamp (1) on the cable of the fuse (3).
- With the ignition switch in the ON position, but with the engine stopped, there will be a continuous current draw of 3.372A.



NOTE

Perform the measurements shown below with the lights off. The readings may vary from those shown depending on the ambient temperature and the temperature of the installation itself; therefore, similar values, although not exactly the same, are still significant to certify the correct operation of the charging system.

- With the engine at idle speed the current delivered (1) is 15.53 A and the voltage on the battery (2) is 14.14 V.



- With the engine at 3,500 rpm the current delivered (1) is 20.07 A and the voltage on the battery (2) is 14.13 V.



- With the engine at 5500 rpm the current delivered (1) is 20.25 A and the voltage on the battery (2) is 14.16 V.



NOTE

When the voltage at the load reaches 14.82V, the generator output current will be close to zero.

Start-up system check

Function

Communicates to the control unit the consent to start the engine.

Operation / Operating principle

Pressing the start button closes the relative circuit, bringing the ECU PIN 65 to zero voltage (closure to ground).

Level in electrical circuit diagram:

Start-up enabling switch

Position:

- Button: on right hand light switch.

Electrical specifications:

- key released: open circuit
- key pressed: closed circuit



CAUTION

BEFORE CARRYING OUT ANY TROUBLESHOOTING, CAREFULLY READ THE GENERAL TROUBLESHOOTING CONCEPTS FOR ELECTRICAL DEVICES AT THE BEGINNING OF THE CHECK AND CONTROL SECTION IN THE ELECTRICAL SYSTEM CHAPTER.

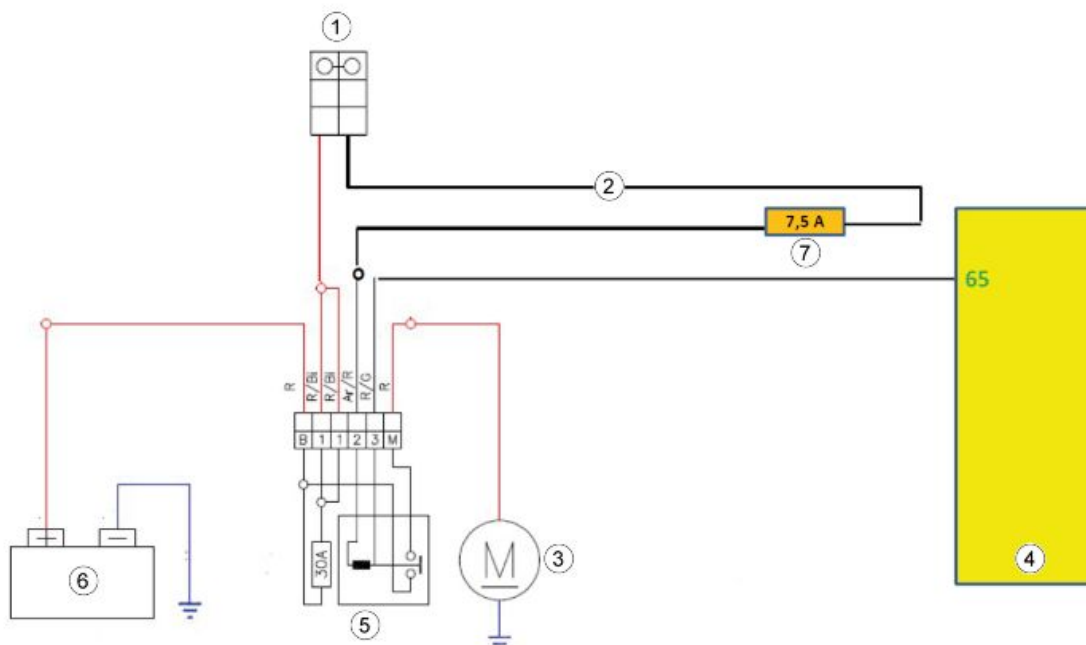

Key:

1. Ignition switch

- 2. Starter button
- 3. Starter Motor
- 4. 11MP ECU
- 5. Starter relay
- 6. Battery
- 7. Fuse

Lights list

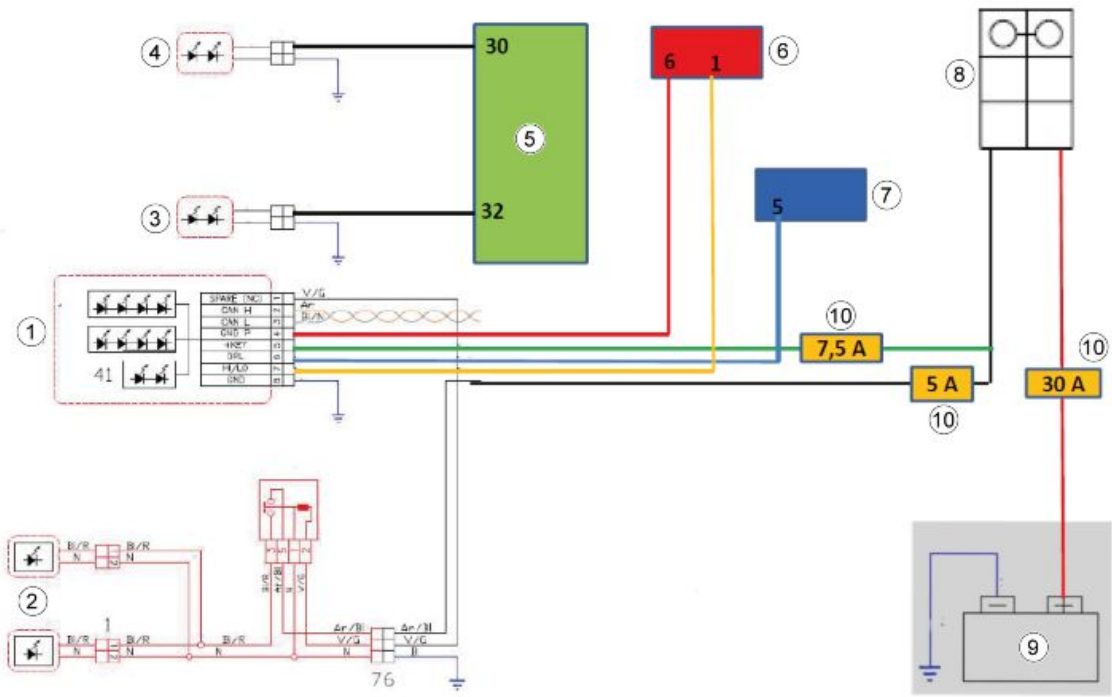

HEADLAMP

Key:

- 1. Headlamp
- 2. Fog lights
- 3. Front left turn indicator
- 4. Front right turn indicator
- 5. Instrument cluster
- 6. Left light switch
- 7. Right light switch
- 8. Ignition switch
- 9. Battery
- 10. Fuse

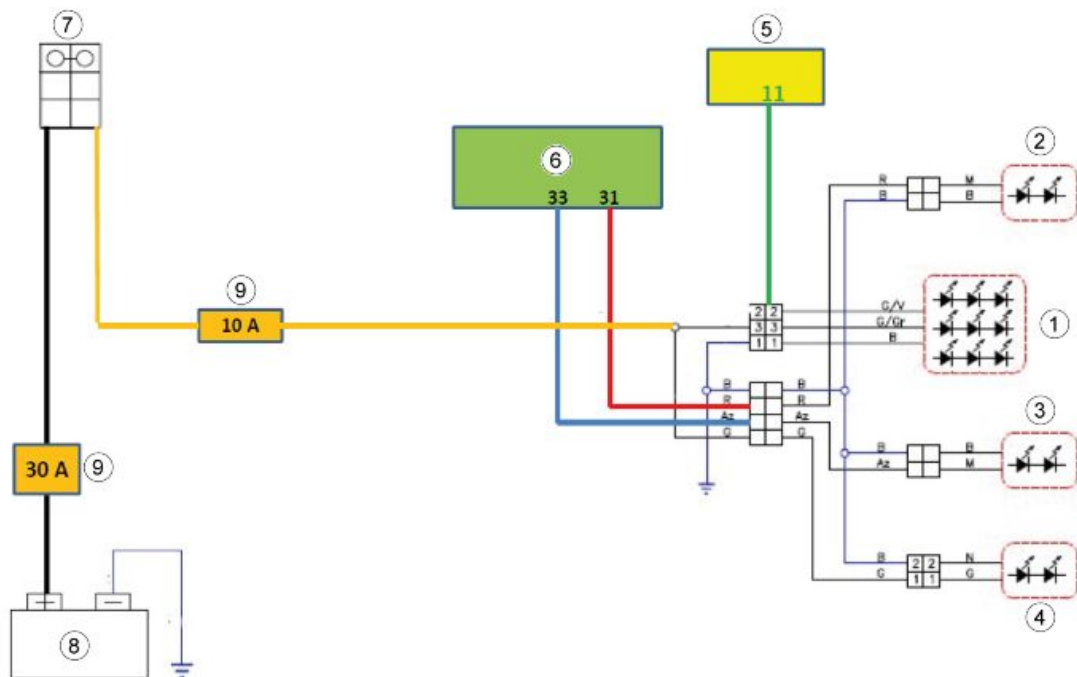

TAILLIGHT

Key:

1. Taillight
2. Rear right turn indicator
3. Rear left turn indicator
4. Licence plate lamp
5. 11MP ECU
6. Instrument cluster
7. Ignition switch
8. Battery
9. Fuse

The 11MP control unit (5) controls the activation of the STOP light via pin 11.

Fuses

To check:

- Turn the ignition switch to "OFF" to avoid an accidental short circuit;
- Remove the passenger saddle to access the auxiliary fuses;
- Remove the driver saddle and the battery cover to access the main fuses;
- Remove the fuse box cover;
- Take out one fuse at a time and check if the filament is broken;
- Before replacing the fuse, investigate the cause of the problem and eliminate it;

- If the fuse is damaged, replace it with one of the same current rating.

NOTE

IF THE SPARE FUSE IS USED, REPLACE WITH ONE OF THE SAME TYPE IN THE CORRESPONDING FITTING.

MAIN FUSES MSS V100

Specification	Desc./Quantity
40A fuse	Charging the battery
30A fuse	Loads of the entire vehicle
spare fuses	

They are located under the tank, in front of the E.C.U.

**AUXILIARY FUSES (1)**

Specification	Desc./Quantity
A) 10A fuse	Rear position, horn, licence plate light
B) 5A fuse	Fog lights live positive lead (where provided)
C) 7.5A fuse	ECU key-on positive, ABS key-on positive, instrument panel key-on positive, RH light switch key-on positive, inertial platform key-on positive, stand key-on positive, TMPS key-on positive (if provided), rear radar key-on positive (if provided), main ignition relay
D) 7.5A fuse	Key-on power for smart EC key-on positive (if provided)
E) 7.5A fuse	GMP key-on positive (if provided), OBD key-on positive, anti-theft system positive
F) 7.5A fuse	Headlamp key-on positive
G) 3A fuse	USB 1 and 2 key-on positive (2 if provided)
Q) Spare fuses	

They are located on the tail fairing, under the passenger saddle

AUXILIARY FUSES (2)

Specification	Desc./Quantity
H) 15A fuse	Power supply for: Fan relay, ECU, fuel pump relay, RH and LH lambda probe, RH and LH injectors, RH and LH coils, secondary air valve, urge valve
I) 5A fuse	Power supply for: anti-theft device provision, OBD2
L) 7.5A fuse	Fan power feed
M) 7.5A fuse	ECU permanent positive lead
N) fuse of 10A	MGCA aerodynamic protection power supply
O) 5A fuse	Instrument panel power supply (turn indicators)
P) 20A fuse	ABS power feed
Q) Spare fuses	

They are located on the tail fairing, under the passenger saddle

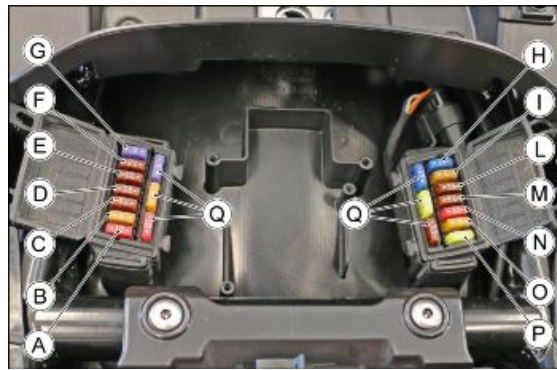

Control unit

ENGINE TONE WHEEL PROGRAMMING PROCEDURE

- Using the PADS diagnostic tool, perform the "Reset wheel tooth values";
- Bring the engine to a temperature above 80°;

Then proceed as described:

- In neutral position, with the side stand extended/open and with the vehicle absolutely immobile, quickly bring the engine above 7000 RPM (it is not necessary to stay there, it is sufficient to exceed it);
- Close the throttle completely and wait for the engine to go down to idle speed;
- Repeat this procedure three times.

The success of the procedure is confirmed by the immediate turning off of the MIL light (in the presence of other errors the MIL light may remain on but in any case stops flashing).

Switch off the panel and wait for at least one minute (Power Latch).

CAUTION

DURING THE ENGINE TONE WHEEL PROGRAMMING PROCEDURE, THE VEHICLE'S SPEED MUST ALWAYS BE 0 km/h.

IN CERTAIN CASES, EVEN SMALL VIBRATIONS GENERATED BY THE ENGINE (WITH THE ENGINE IN NEUTRAL POSITION AND THE SIDE STAND EXTENDED/OPEN, THE INSTRUMENT PANEL DOES NOT DETECT THE VEHICLE'S SPEED), MAY CAUSE THE PROCEDURE TO FAIL, WHICH



MEANS IT HAS TO BE REPEATED. IN THIS CASE, REPEAT THE PROCEDURE WITH THE SIDE STAND CLOSED AND VEHICLE IN NEUTRAL ALWAYS PAYING EXTREME ATTENTION. FOR MORE SAFETY, POSSIBLY BLOCK THE VEHICLE AGAINST A WALL.

CAUTION

PROGRAMMING OF THE TONE WHEEL TAKES PLACE DURING THE RELEASE PHASE OF THE THROTTLE (FROM 7000 rpm TO IDLE RPM). IN THIS DESCENDING PHASE THE THROTTLE GRIP MUST REMAIN COMPLETELY CLOSED.

ASC CONTROL UNIT (ELECTRONIC SUSPENSION CONTROL UNIT)

(if applicable)

ASC CONTROL UNIT - Diagnosis**Function**

It manages the ASC system, the system safety checks and the self-diagnosis function.

Level in electrical circuit diagram:

ASC Control Unit

Position:

- on the vehicle: at the front, connected to the instrument cluster mount.
- connector: on 34 PIN connector control unit (24 of which are active)

Pin out: See CONNECTORS paragraph

DIAGNOSTIC TOOL:INFO

(screen page/example values with key ON)

- Hardware version / - (indicates the hardware version)
- BOOT version / -
- Software version / -
- Map identification / -

DIAGNOSTIC TOOL:ACTIVATIONS

- Suspension test - Softest setting - min damping / Minimum damping preload check
- Suspension test - Hardest setting - max damping / Maximum damping preload check

DIAGNOSTIC TOOL: ERRORS**ASC ELECTRONIC SUSPENSION ECU ERROR**

Code	Description / Symptoms
D08600	Invalid X-axis acceleration sensor signal
D08601	Invalid Y-axis acceleration sensor signal
D08602	Invalid Z-axis acceleration sensor signal
D08603	Invalid WX angular value sensor signal
D08604	Invalid WY angular value sensor signal
D08605	Invalid WZ angular value sensor signal
D08606	Invalid front wheel speed sensor signal
D08607	Invalid rear wheel speed sensor signal
D08608	Invalid front brake pressure sensor signal
D08609	Invalid rear brake pressure sensor signal
D0860A	Invalid accelerator sensor signal
D0860B	Invalid bank angle sensor signal

Code	Description / Symptoms
D0860C	Invalid suspension mode sensor signal
D0860D	Invalid front compression block HMI signal
D0860E	Invalid front rebound block HMI signal
D0860F	Invalid rear compression block HMI signal
D08610	Invalid rear rebound block HMI signal
D08611	Invalid steering damper block HMI signal
D08612	Invalid OBTI acceleration HMI signal
D08613	Invalid OBTI brake HMI signal
D08614	Invalid OBTI angle HMI signal
D08615	Invalid OBTI front stability HMI signal
D08616	Invalid OBTI rear stability HMI signal
D08617	Invalid OBTI steering damper HMI signal
D08618	Invalid engine RPM sensor signal
D08619	Invalid ignition signal
D08700	Communication interrupted with instrument cluster ECU (DSB1)
D08701	Communication interrupted with instrument cluster ECU (DSB2)
D08702	Communication interrupted with inertia measurement ECU (IMU1)
D08703	Communication interrupted with inertia measurement ECU (IMU2)
D08704	Communication interrupted with inertia measurement ECU (IMU3)
D08705	Communication interrupted with ABS ECU (ABS1)
D08706	Communication interrupted with ABS ECU (ABS3)
D08707	Interrupted communication with infotainment ECU (GMP1)
D08708	Communication interrupted with engine ECU (ECU1)
D08800	Can Bus-Off

ECU 11MP (ENGINE ECU)

The Marelli 11 MP ECU is a highly advanced Ride By Wire injection system that controls the opening and closing of the throttle bodies (via DC motors) and independently manages the injection time and ignition advance of the engine cylinders.

The 11MP allows very precise engine management that complies with **EURO 5** regulations, supporting mapping selection, cruise control and traction control.

During driving, the control unit receives the throttle opening command via a two-track potentiometer called the **Demand** (throttle knob). The control unit will then manage the outputs of:

- Throttle opening;
- Injection time;
- Ignition advance.

There are two separate connectors; the larger (1) is dedicated to engine management and the smaller (2) to vehicle interface.



Removal

- Remove the driver's seat and battery beforehand.
- Lift the slide (1) and disconnect the connector (2).



- Lift the slide (3) and disconnect the connector (4).

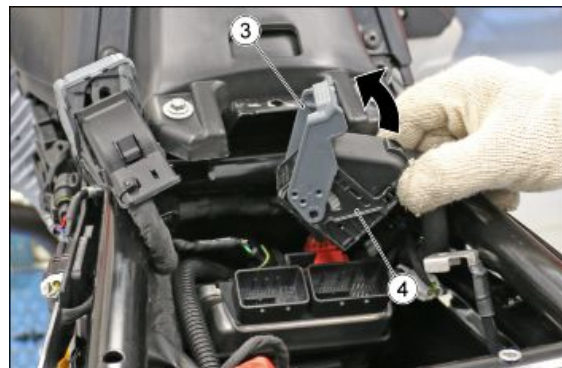

- Remove the ECU (5) by pulling it upwards.

**NOTE**

WHEN REASSEMBLING THE CONNECTORS, THE SLIDES MUST SLIDE FREELY UP TO THE LIMIT STOP, THUS FACILITATING THE CONNECTOR'S INSERTION: THE CATCH SHOULD SNAP INTO PLACE ONCE THE LIMIT STOP IS REACHED.

NOTE

If the 11MP control unit is replaced, it will self-adapt to the vehicle parameters. During the first tens of kilometres of vehicle use, the control unit will learn the parameters necessary for the regular operation of the engine and the vehicle itself.

CONTROL UNIT - Diagnosis**Function**

It manages the Ride by wire system, the injection/ignition, the system safety checks and the self-diagnostic function

Level in electrical circuit diagram:

Each level in which the main component involves the control unit

Position:

- on the vehicle: under the driver's seat, between the tank and the battery.

Pin out: See CONNECTORS paragraph

(screen page/example values with key ON)

- Drawing number / - (identified inserted by the manufacturer)
- HW number / - (indicates the Hardware number)
- Hardware version / -
- Mapping / - (indicates the mapping number)
- Software version / -
- Type approval number / -
- ISO code / -
- Marelli SW code / -
- Serial number (NIP)
- Author of the latest progr. / - (author of the latest programming)
- Internal code (IDEEKE) / -
- Internal code (IDVAG1) / -
- Hardware code / - (indicates the hardware code)
- VIN / - (vehicle identification number)

ADAPTIVE FUEL CORRECTION (EEPROM RESET)

Adaptive fuel correction aims to store the lambda correction when it corresponds to a stable steady state.

It is divided into two tables for each cylinder, one for the cold engine and one for the warm engine; the diagnostic tool will only display the adaptive parameter applied by the ECU at that precise moment (hot/cold engine, throttle opening, engine revs).

The adaptive correction is deleted when the Adaptive Parameter Reset (**EEPROM RESET**) is carried out via the diagnostic tool, or when a new mapping is loaded.

It is recommended to perform the **EEPROM RESET** on the occasion of:

- Air filter cleaning;
- Spark plug replacement;
- Valve clearance adjustment;
- Repairs to the intake or exhaust system.

DERATING STRATEGY

Using the **engine oil temperature sensor**, the 11MP control unit is able to monitor and control the engine oil temperature through the DERATING strategy, preventing it from exceeding **150° C (302° F)**. The DERATING strategy starts as soon as the engine oil exceeds **113° C (235.4° F)** and involves a progressive decrease in engine torque through a reduction in engine load and ignition advance (to avoid detonation problems) from **7500 rpm**.

Using the P.A.D.S. diagnostic tool, it is possible to check the **torque reduction (up to -40%)** present at the time of connection.

RECOVERY STRATEGIES

Various recovery strategies, characterised by a progressively increasing level of impact on vehicle driving, are provided to ensure maximum driving safety while minimising inconvenience for the customer in the event of a breakdown.

Depending on the impact the failure will have on the safe running/integrity of the engine, the indication on the instrument cluster may be more or less obvious:

Level 1: error recognised, but not of safety significance and not noticeable to the driver => No indication on the instrument cluster

Level 2: Safety-insignificant error but noticeable to the driver => Fixed warning light and display of **URGENT SERVICE** message on the instrument cluster.

Level 3: error impairing safety => Flashing warning light and display of the message **URGENT SERVICE** on the instrument cluster.

Four Recovery are possible depending on the severity of the technical problem detected:

1. Recovery Degraded Torque: torque and maximum engine speed are reduced, so as to avoid critical driving situations or engine damage. Such a recovery is, for example, applied when one of the tracks of the TPS or the DEMAND SENSOR fails.

2. Recovery Limp Home: the ECU manages throttle position, advance and injection time in such a way as to keep the engine at a constant idle speed, regardless of the action on the throttle knob. The rider is thus able to drive the vehicle to the repair shop (e.g. in the event of failure of both DEMAND SENSOR tracks).

3. Recovery dead throttle valve: the throttle valve motor is switched off, the valve then moves to the rest position (which is slightly open). In turn, the ECU manages the advance and injection time so as to keep the engine at an accelerated idle speed. This recovery is applied, for example, when both traces of the TPS are faulty or when the MAP sensor reading is implausible (throttle body off).

4. Recovery engine stop: The control unit shuts down the engine when it detects its own internal error or finds that the throttle cannot be set to the accelerated idle position.

DIAGNOSTIC TOOL - PARAMETERS:

Italian PADS description / English PADS description

- Engine speed / Engine RPM
- Temperatura aria / Air temperature
- Temperatura aria ante recovery / Air temperature before recovery
- Temperatura motore / Engine temperature
- Temperatura motore ante recovery / Engine temperature before recovery
- Temperatura motore all'avviamento / Engine temperature upon starting
- Segnale potenziometro posizione manopola (traccia A) / Handgrip position potentiometer signal (trace A)

- Segnale potenziometro posizione manopola (traccia B) / Handgrip position potentiometer signal (trace B)
- Apertura manopola acceleratore in percentuale / Accelerator handgrip opening in percentage
- Tensione farfalla destra potenziometro 1 / 1 potentiometer right throttle voltage
- Tensione farfalla destra potenziometro 2 / 2 potentiometer right throttle voltage
- Tensione farfalla sinistra potenziometro 1 / 1 potentiometer left throttle voltage
- Tensione farfalla sinistra potenziometro 2 / 2 potentiometer left throttle voltage
- Angolo farfalla destra potenziometro 1 / 1 potentiometer right throttle angle
- Angolo farfalla destra potenziometro 2 / 2 potentiometer right throttle angle
- Angolo farfalla sinistra potenziometro 1 / 1 potentiometer left throttle angle
- Angolo farfalla sinistra potenziometro 2 / 2 potentiometer left throttle angle
- Pressione aspirazione / Induction pressure
- Valore in tensione del sensore pressione / Pressure sensor value when excited
- Pressione stimata aspirazione / Intake estimated pressure
- Anticipo cilindro attuale / Actual cylinder advance
- Anticipo cilindro destro / RH cylinder ignition advance
- Anticipo cilindro sinistro / LH cylinder ignition advance
- Tempo iniezione cilindro destro / RH cylinder injection time
- Tempo iniezione cilindro sinistro / LH cylinder injection time
- Regime nominale di minimo / Rated idle speed
- Tensione batteria / Battery voltage
- Tensione sonda lambda destra / RH lambda sensor voltage
- Tensione sonda lambda sinistra / LH lambda sensor voltage
- Correzione lambda destra / Right lambda correction
- Correzione lambda sinistra / Left lambda correction
- Efficienza iniezione cilindri / Cylinder injection efficiency
- Correzione angolo farfalla / Throttle angle correction
- Portata carburante per ciclo motore / Fuel flow rate per engine cycle
- Correzione adattativa carburante cilindro destro / RH cylinder fuel adaptive correction
- Duty Cycle valvola aria secondaria / Secondary air valve duty cycle
- Posizione inferiore farfalla destra / Right throttle lower position
- Posizione inferiore farfalla sinistra / Left throttle lower position
- Velocità veicolo / Vehicle speed
- Tempo di Dwell bobina destra / Right coil Dwell time
- Tempo di Dwell bobina sinistra / Left coil Dwell time
- Marcia inserita / In gear
- Velocità ruota anteriore / Front wheel speed

- Circonferenza ruota posteriore / Rear wheel circumference
- Rapporto finale trasmissione / Transmission final ratio
- Correzione adattativa carburante cilindro sinistro / LH cylinder fuel adaptive correction
- Contatore errori blocchetto chiave / Ignition block key error counter
- Tensione sensore marce / Gear sensor voltage
- Valore riduzione di coppia / Torque reduction value

DIAGNOSTIC TOOL - STATUSES:

Italian PADS description / English PADS description

- Controllo sonda lambda destra / RH lambda sensor check
- Controllo sonda lambda sinistra / LH lambda sensor check
- Autoapprendimento farfalla destra / Right throttle Self-Learning
- Autoapprendimento farfalla sinistra / Left throttle Self-Learning
- Stato motore / Engine state
- Modo motore / Engine Mode
- Manopola / Knob
- Cambio in folle / Gear in neutral
- Rele' ventola / Fan relay
- Consenso da immobilizer / Enable from immobilizer
- Stato Ruota fonica / Phonic wheel status
- Cavalletto laterale / Side stand
- Droop sensor / Droop sensor
- Interruttore RUN/OFF / RUN/OFF switch
- Leva frizione / Clutch lever
- Segnale frizione / Clutch signal
- Abilitazione Accensione / Ignition enabling
- Sonda lambda destra / Right-hand lambda sensor
- Sonda lambda sinistra / Left-hand lambda sensor
- Attivazione leva quick shift / Quick Shift Lever Activation
- Stato del sistema cruise control / Cruise Control system status
- Switch qualificato leva freno anteriore / Front brake lever qualified switch
- Switch qualificato leva freno posteriore / Rear brake lever qualified switch
- Switch raw leva freno anteriore / Front brake lever raw switch
- Switch raw leva freno posteriore / Rear brake lever raw switch
- Indica lo stato del tasto relativo al cruise control sul volante / It indicates the status of cruise control button on steering wheel
- Switch Cruise Control '+' / Cruise Control '+' switch
- Switch Cruise Control '-' / Cruise Control '-' switch

- Apprendimento ruota fonica / Phonic wheel learning
- Immobilizer sbloccato tramite codice / Immobilizer unlocked by code
- Codice o segnale immobilizer antenna ricevuto / Antenna immobilizer code or signal received
- Codice Immobilizer / Immobilizer code
- Comunicazione con Immobilizer / Communication with immobilizer

DIAGNOSTIC TOOL - ACTIVATIONS:

Italian PADS description / English PADS description

- Attivazione bobina destra / RH coil actuation
- Attivazione bobina sinistra / LH coil actuation
- Rele' pompa benzina / Petrol pump relay
- Attivazione del contagiri / Rev.counter enabling
- Riscaldatore sonda lambda destra / Right lambda sensor heater
- Iniettore cilindro destro / Right cylinder injector
- Iniettore cilindro sinistro / Left cylinder injector
- Attivazione Elettroventola / Electro fan activation
- Riscaldatore sonda lambda sinistra / Left lambda sensor heater
- Attivazione spia MIL / MIL indicator activation
- Attivazione Valvola Solenoide Aria Secondaria / Activation of the secondary air Solenoid valve
- Luce stop / Stop light

DIAGNOSTIC TOOL - SETTINGS:

Italian PADS description / English PADS description

- Azzeramento EEPROM centralina / Control unit EEPROM reset
- Azzeramento valori ruota fonica / Phonic wheel values reset
- Autoapprendimento farfalla / Throttle Self-Learning
- Scarico file dati memorizzati / Stored data file download
- Scrittura codice VIN / Write VIN
- Reset contatore errori blocchetto chiave / Key switch error counter reset
- Configurazione veicolo con equipaggiamento premium (Km) / Premium equipment vehicle configuration (Km)
- Configurazione veicolo con equipaggiamento premium (Miglia) / Premium equipment vehicle configuration (Miles)
- Configurazione Veicolo Base (Km) / Vehicle configuration basic (Km)
- Configurazione Veicolo Base (miglia) / Vehicle configuration basic (Miles)
- Attivazione cambio Quick Shift / Quick Shift transmission enabling
- Disattivazione cambio Quick Shift / Quick Shift transmission disabling

- Abilitazione sistema TPMS / TPMS system enabling
- Disabilitazione sistema TPMS / TPMS system disabling
- Abilitazione sistema RADAR BLIS / RADAR BLIS system enabling
- Disabilitazione sistema RADAR BLIS / RADAR BLIS system disabling

DIAGNOSTIC TOOL - ERRORS:**11MP ECU ERRORS ENGINE CONTROL UNIT**

Code	Description / Symptoms
P0030	Right lambda heater circuit - Short circuit to negative
P0030	Right lambda heater circuit - Short circuit to positive
P0030	Right lambda heater circuit - Open circuit
P0050	Left lambda heater circuit - Short circuit to negative
P0050	Left lambda heater circuit - Short circuit to positive
P0050	Left lambda heater circuit - Open Circuit
P0105	Right cylinder air pressure sensor - Open Circuit or Short circuit to negative
P0105	Right cylinder air pressure sensor - Short circuit to positive
P0106	Right cylinder air pressure sensor - Below the minimum limit
P0106	Right cylinder air pressure sensor - Above the maximum limit
P0106	Right cylinder air pressure sensor
P0110	Air temperature sensor - Short circuit to negative
P0110	Air temperature sensor - Open Circuit or Short circuit to positive
P0111	Air temperature sensor - functional diagnosis (locked)
P0111	Air temperature sensor - functional diagnosis (intermittent)
P0114	Air temperature sensor - intermittent signal
P0115	Engine temperature sensor - Open Circuit or Short circuit to positive
P0115	Engine temperature sensor - Short circuit to negative
P0116	Engine temperature sensor - functional diagnosis (stuck)
P0116	Engine temperature sensor - functional diagnosis (intermittent)
P0119	Coolant temperature sensor - Intermittent signal
P0120	Potentiometer sensor 1 right throttle valve position - Short circuit to positive
P0120	Potentiometer sensor 1 right throttle valve position - Open Circuit or Short circuit to negative
P0121	Plausibility potentiometer 1 right throttle - signal not plausible
P0130	Right lambda probe - Short circuit to negative (polarised probe only)
P0130	Right lambda probe - Short circuit to positive
P0130	Right lambda probe - Open circuit (polarised probe only)
P0133	Right lambda probe (functional diagnosis) - Slow response
P0134	Right lambda probe (functional diagnosis) stuck - no switching from high
P0150	Left lambda probe - Open circuit (polarised probe only)
P0150	Left lambda sensor - Short circuit to negative (polarised probe only)
P0150	Left lambda sensor - Short circuit to positive
P0153	Left lambda probe (functional diagnosis) - slow response
P0154	Left lambda probe (functional diagnosis) stuck - no switching from high
P0171	Poor status for the right power supply system - Signal above the admissible range
P0172	Rich status for the right power supply system - Signal above the admissible range
P0174	Poor status for the left power supply system - Signal above the admissible range
P0175	Rich status for the left power supply system - Signal above the admissible range
P0196	Engine oil temperature sensor - functional diagnosis (stuck)
P0196	Engine oil temperature sensor - functional diagnosis (intermittent)
P0199	Oil temperature sensor - Intermittent signal
P0201	Right cylinder injector - Short circuit to negative
P0201	Right cylinder injector - Short circuit to positive
P0201	Right cylinder injector - Open Circuit
P0202	Left cylinder injector - Short circuit to negative
P0202	Left cylinder injector - Short circuit to positive
P0202	Left cylinder injector - Open Circuit
P0220	Potentiometer sensor 2 right throttle valve position - Short circuit to positive
P0220	Potentiometer sensor 2 right throttle valve position - Open Circuit or Short circuit to negative
P0221	Plausibility potentiometer 2 right throttle - signal not plausible
P0225	Track hand grip position sensor Pot.A - Short circuit to positive
P0225	Track hand grip position sensor Pot.A - Open circuit or Short circuit to negative
P0230	Fuel pump relay control - Short circuit to negative
P0230	Fuel pump relay control - Short circuit to positive

Code	Description / Symptoms
P0230	Fuel Pump Relay Control - Open Circuit
P0300	Random/multiple cylinder error 1000 detected
P0300	Random/multiple cylinder error 200 detected
P0301	Right cylinder error 1000 detected
P0301	Right cylinder error 200 detected
P0302	Left cylinder error 1000 detected
P0302	Left cylinder error 200 detected
P0336	Engine speed sensor - signal not plausible
P0351	Right coil circuit - Short circuit to positive
P0351	Right Coil Circuit - Open circuit or Short circuit to negative
P0352	Left coil circuit - Short circuit to positive
P0352	Left Coil Circuit - Open circuit or Short circuit to negative
P0410	Secondary air valve control - Short circuit to negative
P0410	Secondary air valve control - Short circuit to positive
P0410	Secondary air valve control - Open circuit
P0443	Bleed valve control circuit Evaporative emission system - Short circuit to positive
P0443	Bleed valve control circuit Evaporative emission system - Short circuit to negative
P0443	Bleed valve control circuit Evaporative emission system - Open circuit
P0480	Cooling fan control - Short circuit to negative
P0480	Cooling fan control - Short circuit to positive
P0480	Cooling Fan Control - Open circuit
P0500	Front wheel vehicle speed sensor/signal - Sensor electrically defective
P0500	Front wheel vehicle speed sensor/signal - Invalid electrical signal
P0500	Front wheel vehicle speed sensor/signal - Sensor signal not plausible
P0500	Front wheel vehicle speed sensor/signal - Invalid plausibility signal
P0505	RPM of idle control system - lower than expected
P0505	RPM of idle control system - higher than expected
P0512	Starter Engine button (functional while pressed) - signal not plausible
P0560	Battery voltage: Below minimum threshold
P0560	Battery voltage - above maximum limit
P0564	GCC button errors (On/Off, +, -,) - Signal not plausible
P0564	GCC button errors (On/Off, +, -,) - Stuck button error
P0569	Control "-" Plausibility - Closed contacts
P0569	Control "-" Plausibility - Open contacts
P0601	EEPROM Error - signal not plausible
P0604	RAM error - signal not plausible
P0605	ROM error - signal not plausible
P060B	A/D converter - circuit not working
P060C	Engine stop due to Safety - circuit not working
P0615	Starter relay - Short circuit to positive
P0615	Starter relay - Open circuit or Short circuit to negative
P0638	Right throttle valve position error - EPOS error
P0639	Left throttle valve position error - EPOS error
P0641	Sensor power supply 1 - Internal electronic fault
P0651	Sensor power supply 2 - Internal electronic fault
P0685	Main relay control - Short circuit to negative
P0685	Main relay control - Short circuit to positive
P0685	Main Relay Control - Open circuit
P0697	Sensor power supply 3 - Internal electronic fault
P0704	Clutch switch plausibility error - signal not plausible
P0914	Analogue operation sensor - short circuit to negative
P0914	Analogue operation sensor - Open circuit or Short circuit to positive
P0915	Analogue operation sensor - blocked or out of range
P1105	Left intake pressure sensor - Short circuit to positive
P1105	Left intake pressure sensor - Open circuit or Short circuit to negative
P1107	Left intake pressure sensor - below the minimum limit
P1107	Left intake pressure sensor - above the maximum limit
P1107	Left intake pressure sensor - signal not plausible
P1305	Stop light relay error - Short circuit to negative
P1305	Stop light relay error - Short circuit to positive
P1305	Stop light relay error - Open circuit
P1309	Flywheel learning error - signal not plausible
P1400	Left throttle valve Limp Home self-learning - LH test failed
P1401	Right throttle valve (opening) spring test self-learning - opening spring test failed
P1402	Right throttle valve lower mechanical stop self-learning - lower mechanical stop error
P1403	Rec. condition self-learning. Right throttle valve - test condition errors

Code	Description / Symptoms
P1404	Right throttle valve supply voltage self-learning - below the minimum limit
P1405	Right throttle valve spring test (re-closure) spring test self-learning - re-closure spring test failed
P1406	Left throttle valve Limp Home self-learning - LH test failed
P1407	Left throttle valve (opening) spring test self-learning - opening spring test failed
P1408	Left throttle valve minimum mechanical position self-learning - test failed
P1409	Left throttle valve recovery condition self-learning - test condition error
P1410	Left throttle valve supply voltage self-learning - below the minimum limit
P1411	Left throttle valve mechanical spring (re-closing) self-learning - test failed
P1412	Right throttle valve self-learning - Test not performed
P1413	Left throttle valve self-learning - Test not performed
P1414	Right throttle valve Self Learning Limp Home Diagnosis - circuit not working
P1415	Left throttle valve Limp Home self-learning diagnosis - circuit not working
P1560	Low Battery Voltage Error - Voltage Error
P1600	Right cylinder manifold small hole error - signal not plausible
P1601	Left cylinder manifold small hole error - signal not plausible
P1602	Right cylinder intake manifold pressure estimation error - pressure too low
P1602	Right cylinder intake manifold pressure estimation error - pressure too high
P1604	Left intake manifold pressure estimation error - pressure too low
P1604	Left intake manifold pressure estimation error - pressure too high
P1606	Incompatibility error between Software and Hardware
P1608	Data buffer full and triggered by special events
P1609	A-PRC functional error - Scheduling error
P1609	A-PRC functional error - CKSUM flash error
P1609	A-PRC functional error - Voltage error
P160C	Safety level2 reset - circuit not working
P1615	ROM checksum test failure report performed on code 2&3 and calibration areas
P1650	Engine event configuration checksum calculation error - signal not plausible
P1753	Brake pedal switch 1 - Signal comparison error
P1754	Brake pedal switch 2 - Signal comparison error
P1760	Stand switch congruence - Signal comparison error
P1900	Quick Shift Sensor Electrical Diagnosis - Short circuit to positive
P1900	Quick Shift Sensor Electrical Diagnosis - Open circuit or Short circuit to negative
P1902	Quick Shift Sensor Functional Diagnosis - Signal blocked in down
P1902	Quick Shift Sensor Functional Diagnosis - Signal blocked in up
P1902	Quick Shift Sensor Functional Diagnosis - Signal not plausible
P1905	Acceleration sensor plausibility AX Sensorbox[3] - Signal failure
P1905	Acceleration sensor plausibility AX Sensorbox[3] - KO sensor
P1907	Acceleration sensor plausibility AY Sensorbox[4] - Signal failure
P1907	Acceleration sensor plausibility AY Sensorbox[4] - KO sensor
P1909	Oscillation Ω z sensor plausibility Sensorbox[1] - Signal failure
P1909	Oscillation Ω z sensor plausibility Sensorbox[1] - KO sensor
P1911	Oscillation Ω z sensor plausibility Sensorbox[2] - Signal failure
P1911	Oscillation Ω z sensor plausibility Sensorbox[2] - KO sensor
P2100	Right throttle valve H-Bridge - Short circuit to negative
P2100	Right throttle valve H-Bridge - Short circuit to positive
P2100	Right throttle valve H-Bridge - Open circuit
P2100	Right throttle valve H-Bridge - Overtemperature, current overload
P210A	Left throttle valve pilot circuit - Short circuit to negative
P210A	Left throttle valve pilot circuit - Short circuit to positive
P210A	Left throttle valve pilot circuit - Open circuit
P210A	Left throttle valve pilot circuit - overcurrent/high internal temperature
P2120	Potentiometer sensor 1 left throttle valve - Short circuit to positive
P2120	Potentiometer sensor 1 left throttle valve - Open circuit or Short circuit to negative
P2121	Potentiometer plausibility 1 left throttle valve - signal not plausible
P2125	Potentiometer sensor 2 left throttle valve - Short circuit to positive
P2125	Potentiometer sensor 2 left throttle valve - Open circuit or Short circuit to negative
P2126	Potentiometer plausibility 2 left throttle valve - signal not plausible
P2130	Track hand grip position sensor Pot.B - Short circuit to positive
P2130	Track hand grip position sensor Pot.B - Open circuit or Short circuit to negative
P2135	Right throttle valve position sensor congruency
P2138	Left throttle valve position sensors - signal not congruent
P2140	Track A-B hand grip position redundancy - signal not congruent
P2158	Rear wheel vehicle speed sensor/signal - Electrically defective sensor
P2158	Rear wheel vehicle speed sensor/signal - Invalid electrical signal
P2158	Rear wheel vehicle speed sensor/signal - Sensor signal not plausible
P2158	Rear wheel vehicle speed sensor/signal - Invalid plausibility signal

Code	Description / Symptoms
P2173	Left cylinder manifold pressure too low error - signal not plausible
P2175	Right cylinder manifold pressure too low error - signal not plausible
P2227	Barometric pressure sensor - generic hardware fault
P2227	Barometric pressure sensor - Plausibility at key on
U0001	CAN line diagnosis (NCM) Bus Off - bus off
U0002	Mute Node CAN Line - Mute Node
U0121	CAN line diagnosis ABS or CLF ECU - signal not plausible
U0121	CAN line diagnosis ABS or CLF ECU - Absent signal
U0125	Box sensor CAN line diagnosis - signal not plausible
U0125	Box sensor CAN line diagnostics - Absent signal
U0140	NQS CAN line diagnosis/Dashboard node absent - absent signal
U0426	Immobilizer error - signal not plausible
U1121	CAN line diagnosis ABS or CLF ECU Frame counter - Absent signal
U1140	NQS CAN line diagnosis/Dashboard package counter - Absent signal

INSTRUMENT CLUSTER ECU ERRORS

Code	Description / Symptoms
B0001	Oil sensor fault
B0002	Oil pressure fault
B0003	Immobilizer: Key code read but not recognised
B0004	Immobilizer: Key code reading error
B0005	Immobilizer: antenna electrical fault (open circuit or short circuit)
B0006	Immobilizer: internal error
B0007	Immobilizer: insufficient number of keys memorised
B0010	Engine overtemperature error
B0012	Fuel sensor disconnected
B0013	Fuel sensor configuration error
B0100	Can line reception error
B0110	Can line transmission error
B0111	Headlight sensor CAN line reception error
B0210	Front brake lever locked
B0211	Rear brake lever locked
B0301	Left turn indicators button locked
B0302	Right turn indicators button locked
B0303	Reset indicator button locked
B0304	MODE UP button locked
B0305	MODE DOWN button locked
B0306	MODE SET button locked
B0307	MODE RIGHT button locked
B0308	MODE RIDING button locked
B0309	CRUISE UP button locked
B0310	CRUISE DOWN button locked
B0311	CRUISE SET button locked

ABS ECU ERRORS

Code	Description / Symptoms
C1D90	Front wheel speed sensor - electrical fault
C1D91	Front wheel speed sensor - extrapolation fault
C1D92	Front wheel speed sensor - periodic fault
C1D93	Front wheel speed sensor - recognition start failure
C1D94	Front wheel speed sensor - phase length supervision fault
C1D95	Front wheel speed sensor - dual frequency control
C1D9A	Front wheel pressure sensor
C1DA0	Rear wheel speed sensor - electric fault
C1DA1	Rear wheel speed sensor - extrapolation fault
C1DA2	Rear wheel speed sensor - periodic fault
C1DA3	Rear wheel speed sensor - recognition start failure
C1DA4	Rear wheel speed sensor - phase length supervision fault
C1DA5	Rear wheel speed sensor - dual frequency control
C1DD3	OSEK error
C1DF0	Defective pump
C1DF1	Pump connection error
C1DF2	Hardware fault
C1DF3	Voltage too low detected in the long term
C1DF4	Voltage too low

Code	Description / Symptoms
C1DF5	Hardware inside error
C1DF7	Voltage too high
C1E11	CAN BUS error
C1E59	Vehicle variant coding error
C1E5A	ABS switch error
C1F13	IMU - Invalid or not plausible data error
C1F14	IMU - Incorrect Voltage
C1F15	IMU - Signal error, before ABS initialisation
C1F18	IMU - CAN communication loss with IMU
C1F19	IMU - Mismatch with IMU ID
U30CB	Code check failed - undervoltage

TPMS ECU ERRORS

Code	Description / Symptoms
B0001	Oil sensor fault
B1000	Faulty receiver
B1011	Front wheel sensor dead battery
B1012	Front wheel high pressure
B1013	Front wheel low pressure
B1014	Front wheel pressure very low
B1015	Front wheel puncture
B1016	Missing front wheel sensor signal
B1017	Front wheel sensor not configured
B1021	Rear wheel sensor dead battery
B1022	Rear wheel high pressure
B1023	Rear wheel low pressure
B1024	Rear wheel pressure very low
B1025	Rear wheel puncture
B1026	Missing rear wheel sensor signal
B1027	Rear wheel sensor not configured

TPMS ECU (Tire Pressure Monitoring System)

- on V100 Mandello S only

Position:

- ECU: under the rider saddle
- Connector: on the control unit



Key:

1. TPMS ECU
2. Ignition switch
3. Battery
4. Fuse

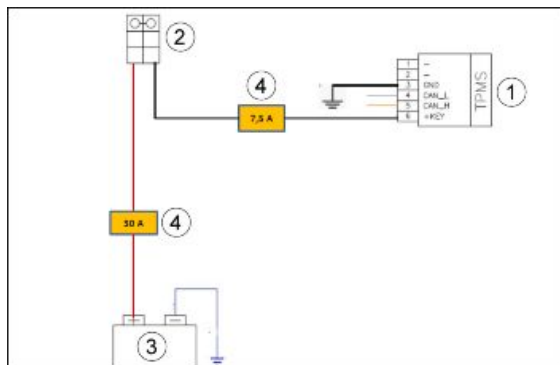

CAV MODULE CONTROL UNIT

Electrical specifications

- Actuator motors electrical resistance: 14 Ohm

Position

- ECU: on the left side of the vehicle under the side panelling, attached to the left side radiator panelling.
- Connector: on the control unit.

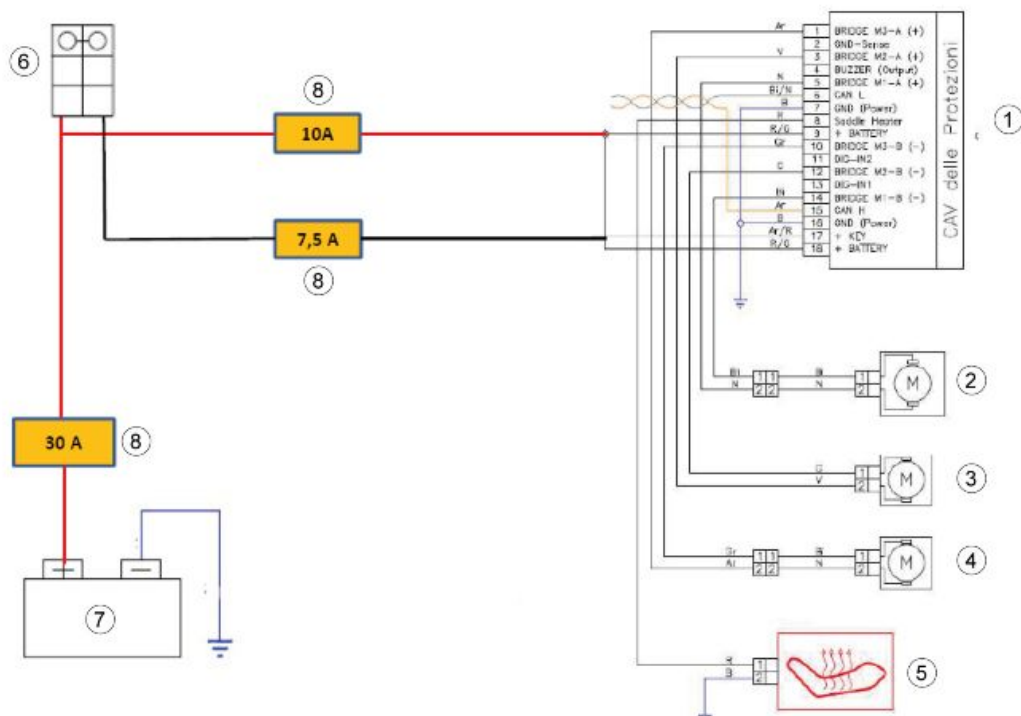

Key:

1. CAV control unit
2. Electrical wind-shield
3. LH aerodynamic protection
4. RH aerodynamic protection
5. Heated saddle
6. Ignition switch
7. Battery
8. Fuse

ABS CONTROL UNIT

Position

- ECU: Fastened to the ABS modulator, under the air filter box and expansion tank.
- Connector: on the control unit.

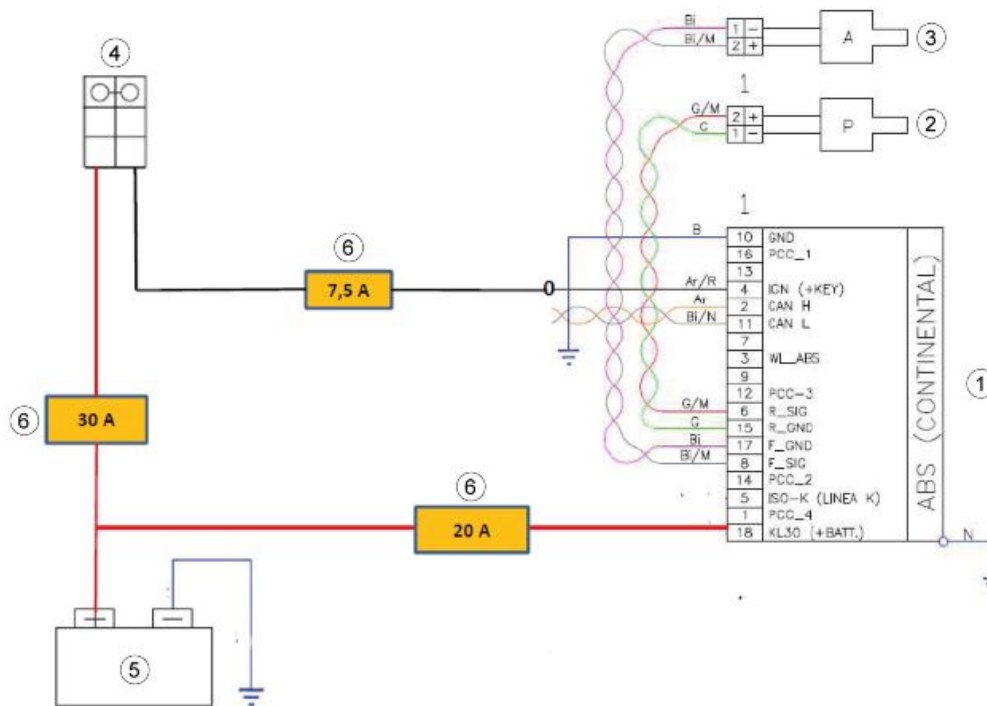

ABS CONTROL UNIT

Key:

1. ABS control unit
2. Rear ABS sensor
3. Front ABS sensor
4. Ignition switch
5. Battery
6. Fuse

Battery

Function

Provides electrical power to vehicle.

Level in electrical circuit diagram:

Charging the battery

Position:

- on the vehicle: under the rider saddle
- connector: on the battery

Electrical specifications: 12 V / 18 Ah

Pin out:

1. Positive pole (red): approx. 12.6 V
2. negative pole (black): ground

DIAGNOSTIC TOOL:PARAMETERS

Battery voltage

- Example value with key ON: 12.0 V
- Example value with engine on: 14.2 V

This is one of the values set by the ECU in the event of recovery mode

Battery voltage before prior to Recovery mode

- Example value with key ON: 12.0 V
- Example value with engine on: 14.2 V

Value determined from signal read without taking considering whether recovery mode is implemented

CAUTION



Do not leave the vehicle with the engine off and the ignition key to "ON". The sophisticated on-board instruments have a high current draw which, if left on with the engine switched off, will discharge the battery in a short time.



Phonic wheel sensor

PICK UP

Function

Provide the ECU with the crankshaft position and thus the engine timing, to adjust the ignition timing of the cylinders.

Position:

Pick up: Inside the timing housing, above the tone wheel.

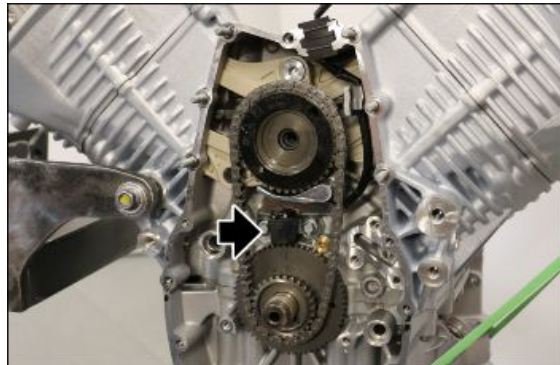

Features:

- Electrical resistance at 20 °C: 100-150 Ohm.
- Air gap distance: 0.5 mm.
- The positive half-wave (1) must precede the negative half-wave (2).

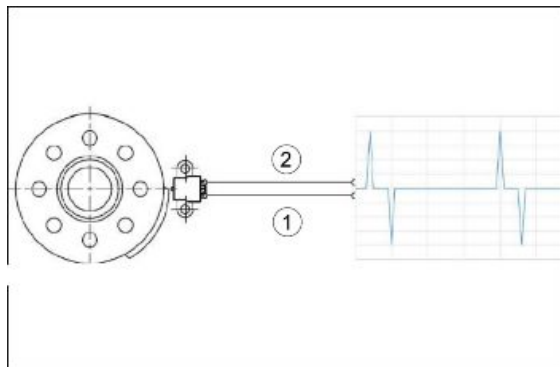

Key:

(1) Pick up

1. Signal.

2. Earth.

(2) 11MP ECU

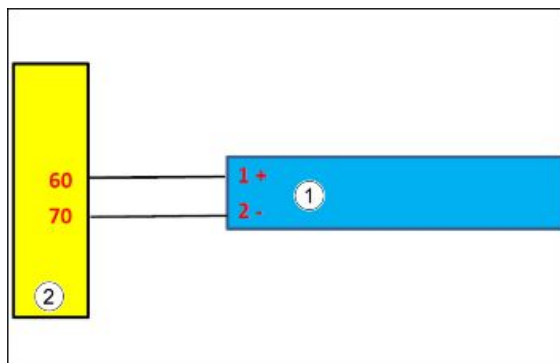

Twistgrip position sensor

Function

Provides the throttle grip position signal to the ECU to activate the throttle valve actuators accordingly.

Operation / Operating principle

Sends an electrical signal to the 11MP ECU, which in turn relays the information to the throttle valve actuators.

Position:

- Right hand grip (accelerator).



Key

(1) PURGE valve

1. Track power supply 1
2. Track 1 ground
3. Track 1 signal
4. Track power supply 2
5. Track 2 ground
6. Track 2 signal

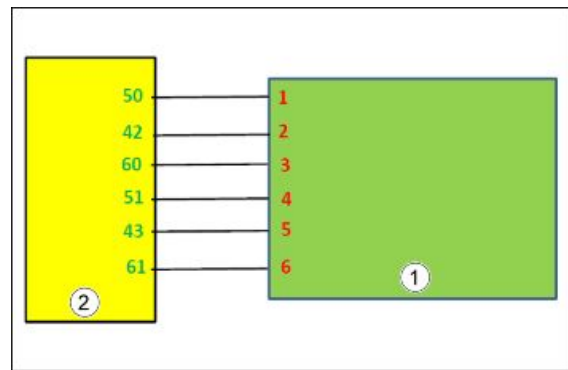

(2) 11MP ECU

CAUTION

BEFORE CARRYING OUT ANY TROUBLESHOOTING, CAREFULLY READ THE GENERAL TROUBLESHOOTING CONCEPTS FOR ELECTRICAL DEVICES AT THE BEGINNING OF THE CHECK AND CONTROL SECTION IN THE ELECTRICAL SYSTEM CHAPTER.

Intake pressure sensor

PRESSURE/Tmap AIR TEMPERATURE SENSOR

Function

The Tmap sensor calculates the pressure and temperature of the engine intake air and sends this data to the control unit, which consequently adjusts the ignition timing and the correct amount of fuel to achieve the correct stoichiometric ratio.

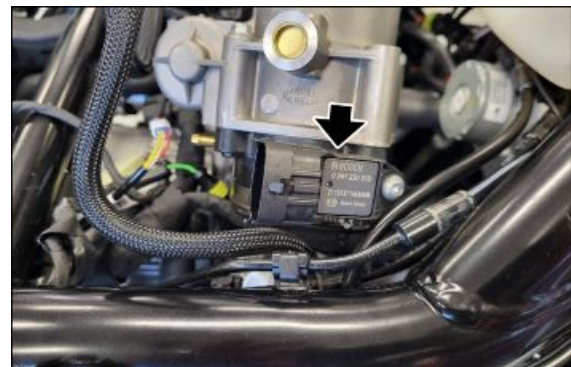

Level in electrical circuit diagram:

intake air pressure sensor

Position:

- on the vehicle: on the throttle bodies, one for each throttle body.
- connector: on the sensor.

Key:

(1) RH cylinder Tmap:

1. Earth.
2. Intake air temperature signal.
3. Pressure sensor power supply.
4. Intake air pressure signal.

(2) LH cylinder Tmap:

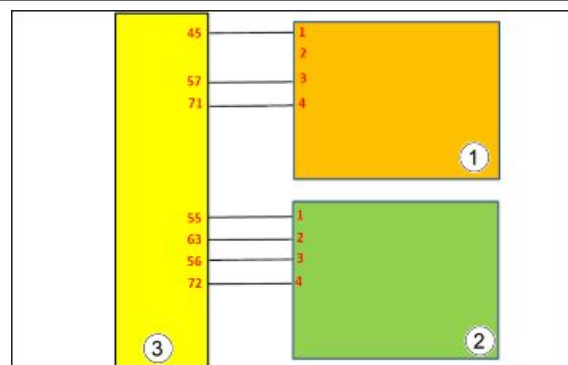

1. Earth.
2. Intake air temperature signal.
3. Pressure sensor power supply.
4. Intake air pressure signal.

(3) 11MP ECU

Engine temperature sensor

ENGINE OIL TEMPERATURE SENSOR

Function

It is used to inform the ECU regarding the engine oil temperature in order to optimize parameter management.

Operation / Operating principle

NTC type sensor (resistance sensor, inversely variable with temperature).

Level in electrical circuit diagram: Temperature sensors

Position:

- Sensor: on the crankcase, under the left head.
- Connector: on the sensor

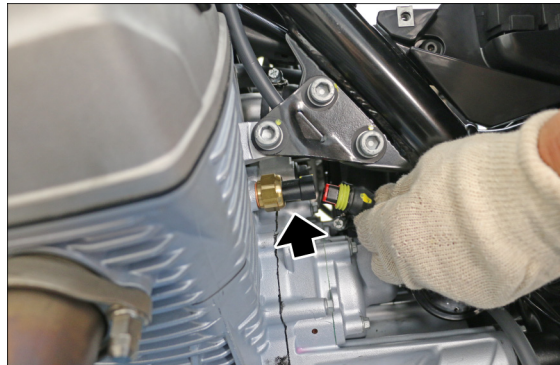

Technical Characteristics

- Electrical resistance at 25 °C: 5000 Ohm
- Maximum temperature: 170°C
- Maximum temperature attainable for short periods: 185°C

Key

(1) Engine oil temperature sensor

1. Signal.
2. Earth.

(2) 11MP ECU

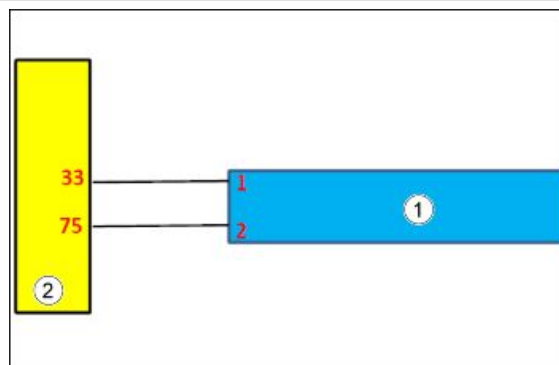

COOLANT TEMPERATURE SENSOR

Function

It is used to inform the ECU regarding the coolant temperature in order to optimize engine parameter management.

Operation / Operating principle

NTC type sensor (resistance sensor, inversely variable with temperature).

Level in electrical circuit diagram: Temperature sensors

Position:

- Sensor: inside the "V" of the motor, screwed onto the thermostatic valve
- Connector: on the sensor



Key

(1) Coolant temperature sensor

1. Earth.
2. /
3. Signal.

(2) 11MP ECU

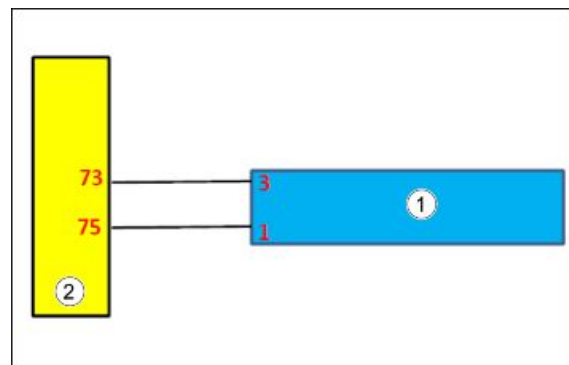

RESISTANCE VALUES BASED ON THE ENGINE TEMPERATURE

Temperature	Minimum resistance	Nominal resistance	Maximum resistance
0°C	7487 Ohm	8039 Ohm	8590 Ohm
20°C	2793 Ohm	2964 Ohm	3135 Ohm
60°C	533.6 Ohm	555.8 Ohm	578.0 Ohm
90°C	191.7 Ohm	197.5 Ohm	203.3 Ohm

Lambda sensor

Function

In charge of telling the control unit whether the mixture is lean or rich

Operation / Operating principle

The 11MP control unit reads and interprets a voltage generated by the difference in oxygen content between the exhaust fumes and the ambient.



It requires no external power but must reach a high operating temperature (closed loop) to operate properly: that is why there is a heating circuit inside.

Closed loop lambda control varies the mixture to continuously oscillate the state of the probe between rich and lean and it is used throughout the range of the emission cycle.

A stoichiometric air/fuel ratio allows the maximum emission reduction efficiency of the catalyst; however, under certain operating conditions, the optimum air/fuel ratio may deviate from the stoichiometric value. In particular, at full load, the ratio must be very different to the rich value for reasons of performance and reliability.



Level in electrical circuit diagram:

Lambda probe

Left lambda position:

- sensor: on the left exhaust manifold
- connector: front left-hand side, secured to radiator support bracket

Right lambda position:

- sensor: on the right exhaust manifold
- connector: front right-hand side, secured to radiator support bracket

Electrical specifications

- Heating circuit: 7-9Ω at ambient temp.
- Output signal to the control unit: 0 - 1000 mV

Left lambda pin out (1):

1. Sensor signal + (black wire)
2. Sensor signal - (grey wire)
3. Heater ground connection (white cable)
4. Heater power supply (white cable)

Right lambda pin out (2):

1. Sensor signal + (black wire)

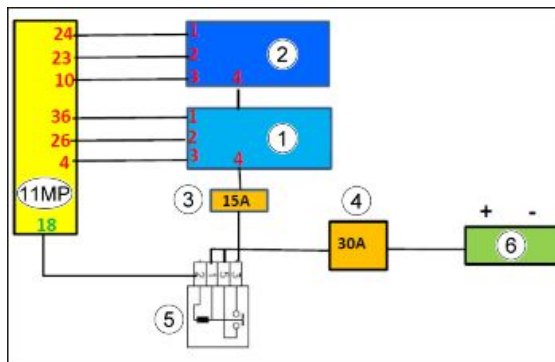

2. Sensor signal - (grey wire)
3. Heater ground connection (white cable)
4. Heater power supply (white cable)

Fuse 15A (3)

Fuse 30A (4)

Injection relay (5)

Battery (6)

Injector

INJECTORS

Function

Ensure the correct amount of fuel in the correct stage of the cycle.

Operation / Operating principle

When the coil is energized, the injector opens and atomizes fuel into the intake duct.

Level in electrical circuit diagram:

Coils and injectors

Position:

Injectors: on the intake duct of the head, one for the right head and one for the left.

Connectors: on injectors.



Features:

- 3-hole injector: $\alpha = 12^\circ$ $\beta = 12^\circ$
- Resistance: $12.5 \pm 5\%$ ohm
- Inductance: $8 \pm 20\%$ mH
- Static flow rate: $4.35 \pm 3\%$ grams / second
- Dynamic flow rate: $8.2 \pm 4.5\%$ mg / pulse

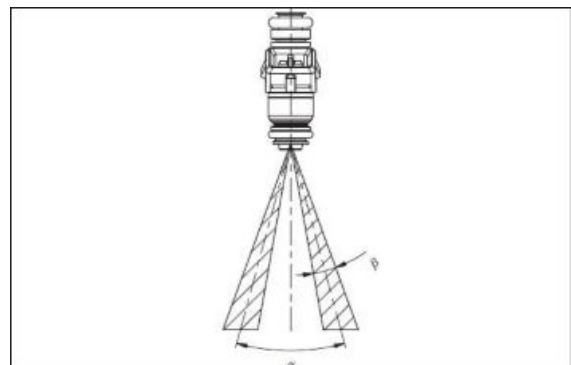

Key:**(1) RH injector:**

1. Power supply +Vbatt
2. Activation from the control unit

(2) LH injector:

1. Power supply +Vbatt
2. Activation from the control unit

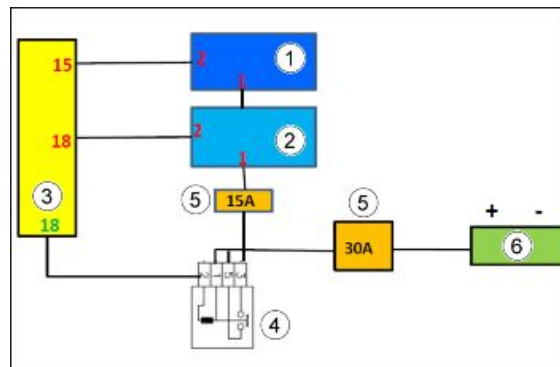
(3) 11MP ECU**(4) Injection relay****(5) Fuse****(6) Battery**

Fuel pump

Function

Fuel pump: keeps pressure of the injectors supply duct.

Fuel level sensor: provides the instrument panel with information on the fuel level in the tank and the reserve status.

Operation / Operating principle

The fuel level sensor varies its resistance according to the position of the relative fuel float immersed in the tank. The signal is read by the instrument cluster that translates it in visual information for the rider.

Level in electrical circuit diagram

Injection loads relay

Operating specifications

- Power supply voltage 12 V
- Operating pressure 4 bar
- Current consumption $I \leq 4.7$ A

Position

- On the vehicle: on the tank.
- Connectors: on the upper part of the tank, (1) fuel pump (2) fuel level sensor

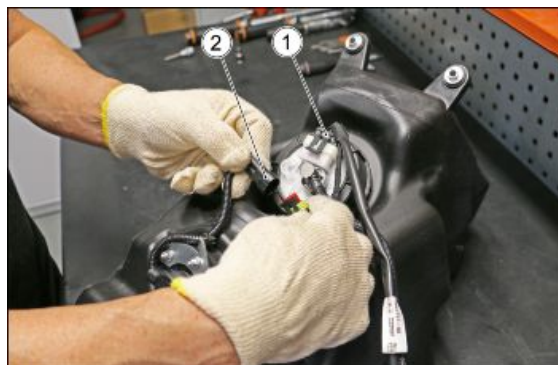

Pin Out :

1. Not connected.
2. Earth.
3. Not connected.
4. Not connected.
5. Fuel pump relay power supply.

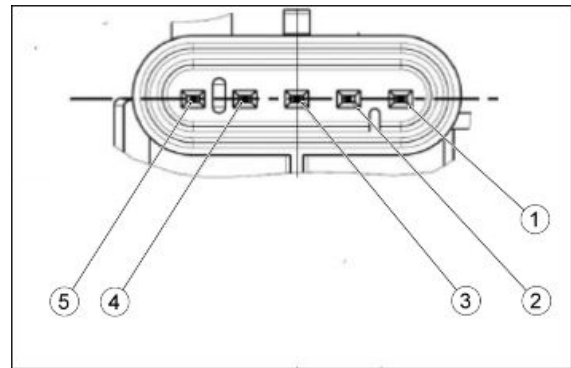
**Electrical circuit**

1. Fuel pump.
2. 11MP ECU.
3. Fuel pump relay.
4. Injection relay.
5. Fuse.
6. Battery.

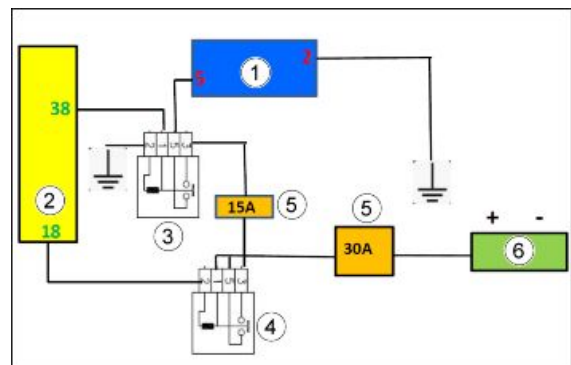
**Coil****Function**

Spark generation

Operation / Operating principle

With inductive discharge

Level in electrical circuit diagram:

coils and injectors

Position:

- On the valve cover, integrated into the spark plug cap.
- Connector: front part vehicle, between the throttle bodies and the chassis.

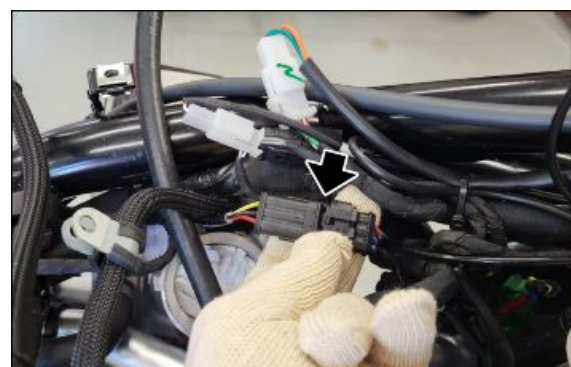

Electrical specifications:

- Primary circuit resistance (pin 1 and 3):
650 ± 50 mohm
- Secondary circuit resistance: 4 ± 0.5
Kohm

Right coil pin out (1):

1. Power supply (+Vbatt)
2. Secondary circuit ground connection
3. Activation from the 11MP control unit

Left coil pin out (2):

1. Power supply (+Vbatt)
2. Secondary circuit ground connection
3. Activation from the 11MP control unit

Key:

1. Right cylinder coil.
2. Left cylinder coil.
3. 11MP ECU
4. Injection relay.
5. Fuse.
6. Battery.

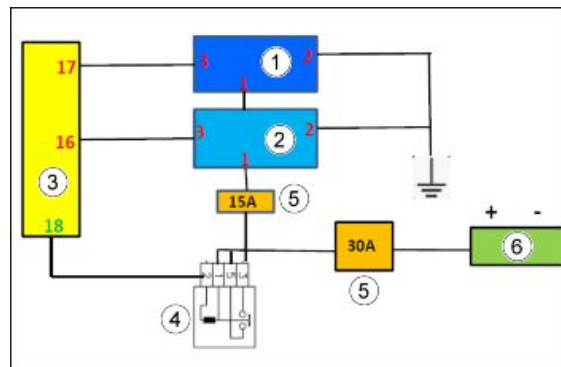
**CAUTION**

BEFORE CARRYING OUT ANY TROUBLESHOOTING, CAREFULLY READ THE GENERAL TROUBLESHOOTING CONCEPTS FOR ELECTRICAL DEVICES AT THE BEGINNING OF THE CHECK AND CONTROL SECTION IN THE ELECTRICAL SYSTEM CHAPTER.

Throttle body**Function**

To send the throttle position to the injection control unit and to activate the throttle itself based on the request from the control unit

Operation / Operating principle

All the unit internal components (potentiometer and electric motor) are contactless; therefore, no electrical diagnostic is possible for the throttle body, but for the circuits connected to it only.

Level in electrical circuit diagram:

Throttle and handgrip sensor control (Demand)

Position:

- on the vehicle: under the air filter box
- connector: on the throttle body

RH cylinder throttle body Pin Out (1):

1. TPS 1 signal
2. TPS power supply
3. Throttle body engine positive
4. TPS 2 signal
5. Throttle body engine ground
6. TPS ground

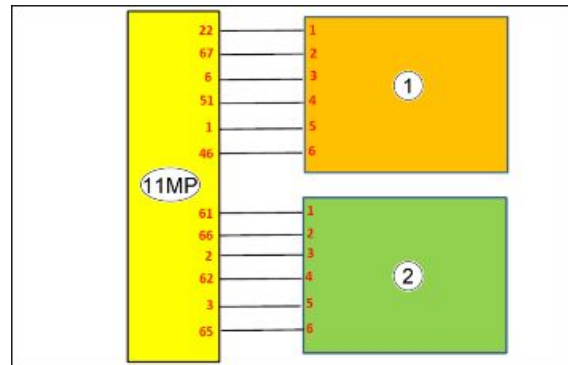

Left cylinder throttle body Pin Out (2):

1. TPS 1 signal
2. TPS power supply
3. Throttle body engine positive
4. TPS 2 signal
5. Throttle body engine ground
6. TPS ground

THROTTLE VALVE OPENING ANGLE

The angle of rotation of the accelerator is coupled with a torque request, which in turn determines that controller the choice of the 11MP ECU regarding the opening angle of the throttle valves. In doing so, the ECU will also take into account other key parameters such as the gear engaged, the number of engine revolutions and the engine mapping chosen.

Depending on the actual position of the throttle valves and the number of engine revolutions, the quantity of fuel and the ignition advance to be applied will be determined.

The intake air amount is calculated by cross-referencing the **TPS** and **TMAP** signals. The injection time and ignition advance are determined according to the engine load and the number of revolutions (**TPS** signal and **PICK UP** signal).

The intake pressure is continuously monitored and if it deviates from the set reference values, the ECU will apply a throttle valve angle correction. This is to obtain the alignment of the actual pressure values (**TMAP**) with the reference values (mapped tables).

The idle speed is managed by the 11MP ECU by adjusting the:

- Ignition advance;
- Throttle bodies opening.

THROTTLE VALVE OPENING ANGLE CORRECTION

The throttle valve opening angle correction strategy is only applied at idle speed and **after the cranking phase**.

In fact, the throttle valve correction starts operating when the lambda probe check starts. From the throttle correction value it is possible to determine whether the engine has ventilation problems (in the case of corrections during closure) or fouled bodies (in the case of corrections during).

A negative correction $\square - 0.6^\circ$ indicates low vacuum in the manifold, which may be generated by:

- A leakage of air,
- Poor sealing of exhaust valves,
- Timing system error.

A positive correction $\square + 0.6^\circ$ indicates too much vacuum in the manifold, which may be generated by:

- dirty and fouled throttle bodies.

Engine oil pressure sensor

ENGINE OIL PRESSURE SENSOR

Function

Indicates the instrument cluster if there is enough oil pressure 0.33 bar (4.8 PSI) in the engine.

Operation / Operating principle

Switch normally open. With oil pressure lower than 0.33 bar (4.8 PSI), closed circuit.

Level in electrical circuit diagram

Low fuel and oil pressure.

Position

- Sensor: inside the "V" of the engine, on the front side, under the thermostatic valve
- Connector: on the sensor.

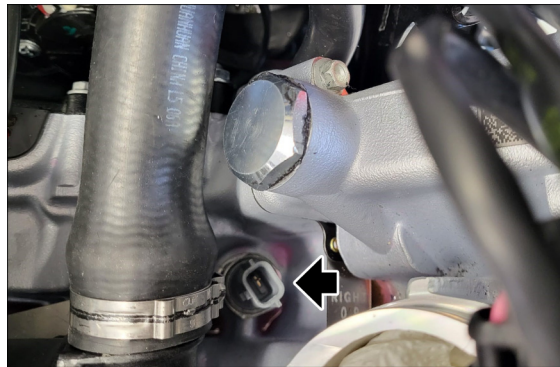

Electrical specifications

- Engine off: closed circuit (continuity).
- With engine started: open circuit (infinite resistance).

Key

1. Oil pressure sensor.
2. 11MP ECU

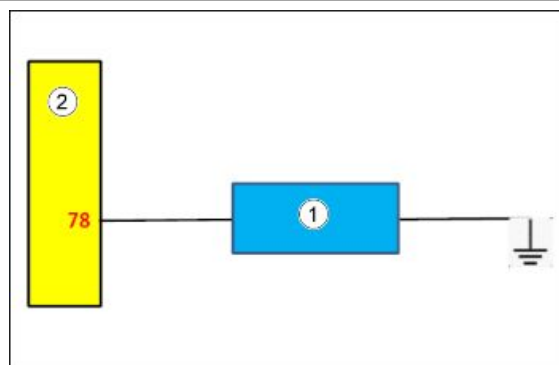

Neutral sensor

GEAR SENSOR

Function

It is used to indicate to the ECU which gear is engaged.

Operation / Operating principle

Each gear engaged has a sensor position, which in turn will have a higher output voltage as the gear engaged increases.



Position:

- On the cover of the box of the gearbox, under the selector shaft.

Output voltage:

- First gear: $0.625\text{ V} \pm 0.1\text{ V}$
- Second gear: $1.375\text{ V} \pm 0.1\text{ V}$
- Third gear: $2.125\text{ V} \pm 0.1\text{ V}$
- Fourth gear: $2,875 \pm 0.1\text{ V}$
- Fifth gear: $3.625\text{ V} \pm 0.1\text{ V}$
- Sixth gear: $4.375\text{ V} \pm 0.1\text{ V}$
- NEUTRAL: $1\text{ V} \pm 0.09\text{ V}$

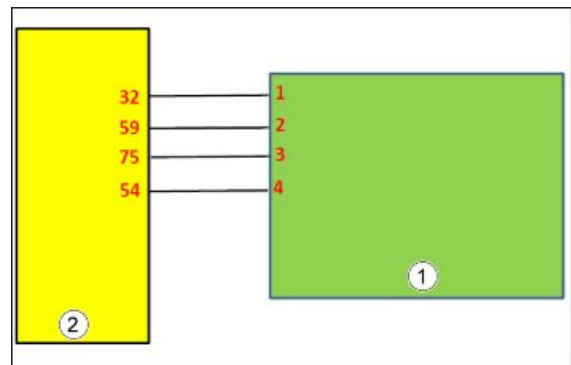

Key

(1) Gear sensor

1. Gear signal.
2. Neutral signal.
3. Earth.
4. Power supply.

(2) 11MP ECU

Clutch lever sensor

Function

Indicates the clutch lever position to the control unit.

Operation / Operating principle

If a gear is engaged but the clutch is engaged, meaning with the circuit closed to ground, there is consent to start the vehicle.

Level in electrical circuit diagram:

Start enable switches

Position:

- Switch: under the clutch lever.

Electrical specifications:

- Clutch lever pulled: closed circuit (continuity)
- Clutch lever released: open circuit (infinite resistance).



CAUTION

BEFORE CARRYING OUT ANY TROUBLESHOOTING, CAREFULLY READ THE GENERAL TROUBLESHOOTING CONCEPTS FOR ELECTRICAL DEVICES AT THE BEGINNING OF THE CHECK AND CONTROL SECTION IN THE ELECTRICAL SYSTEM CHAPTER.

Key:

(1) Clutch lever switch.

- (A) Lever pulled.
- (B) Lever released.

(2) Rear brake lever switch.

- (A) Lever pulled.
- (B) Lever released.

(3) 11MP ECU.

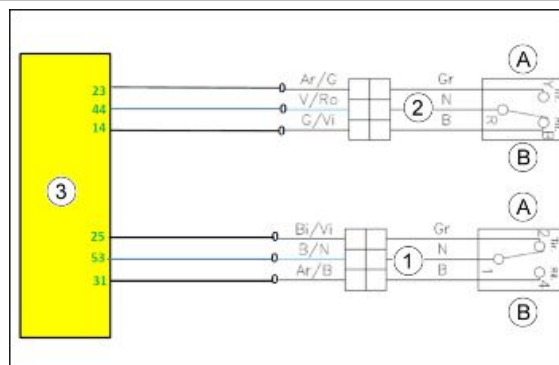

NOTE

The front brake switch is not provided. Operation of the front brake lever results in pressure changes detected by the ABS control unit pressure sensor which, via CAN, communicates with the 11 MP control unit.

Side stand sensor

Function

indicates to the control unit the position of the side stand

Operation / Operating principle

If the gear is engaged and the side stand is unfolded, and therefore the circuit is open, the control unit does not enable vehicle start-up or shuts off the engine if it is rotating



Level in electrical circuit diagram:

Start enable switches

Position:

- sensor: on the stand support, under the rider's left footrest

Stand pin out (1):

1. Fuel system
2. Output A
3. Ground
4. Output B

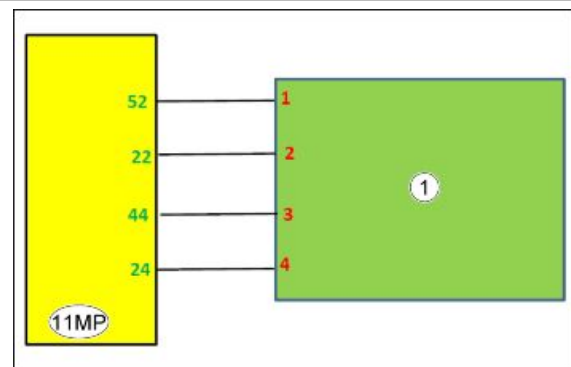

Electrical specifications:

- Stand up: closed circuit (continuity)
- Stand down: open circuit (infinite resistance)

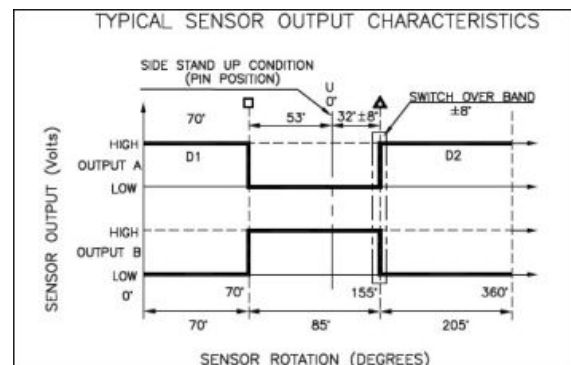

Electric fan circuit

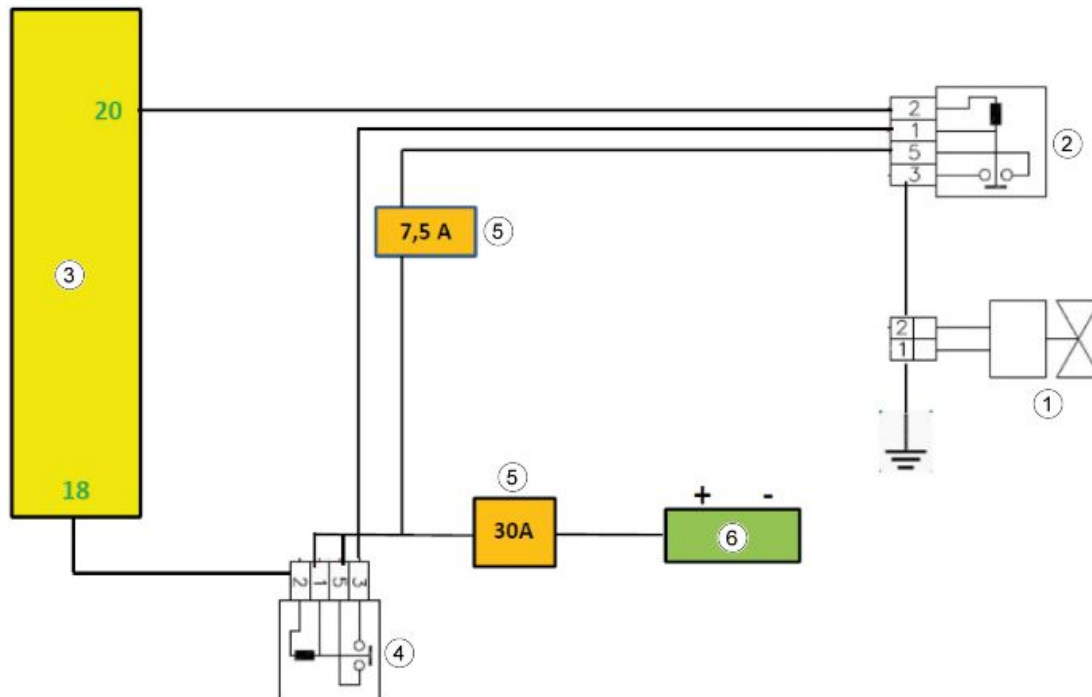

RADIATOR ELECTRIC FAN

Key:

1. Electric fan
2. Electric fan relay
3. 11MP ECU
4. Injection relay
5. Fuse
6. Battery

SAS valve actuator

Function

Quickly warms up the catalytic converter and keeps the combustion rich in some critical conditions .

Operation / Operating principle

The valve coil is energized to open the air passage from the filter housing to the exhaust manifolds.

Level in electrical circuit diagram:

Secondary air system

Position:



- (1) The PURGE valve: under the battery compartment, fixed to the canister support.
- (2) Secondary air valve: Under the battery compartment, on the right side of the vehicle.
- Connectors: On the relative valves.

Electrical specifications:

PURGE valve electrical resistance at 20 °C: 24 ± 3 Ohm

Secondary air valve electrical resistance at 20 °C: 21.5 Ohm

Key

(1) PURGE valve

1. Power supply +Vbatt
2. Ground

(2) Secondary air valve

1. Power supply +Vbatt
2. Ground

(3) 11MP ECU

(4) Fuse

(5) Injection relay

(6) Battery

CAUTION

BEFORE CARRYING OUT ANY TROUBLESHOOTING, CAREFULLY READ THE GENERAL TROUBLESHOOTING CONCEPTS FOR ELECTRICAL DEVICES AT THE BEGINNING OF THE CHECK AND CONTROL SECTION IN THE ELECTRICAL SYSTEM CHAPTER.

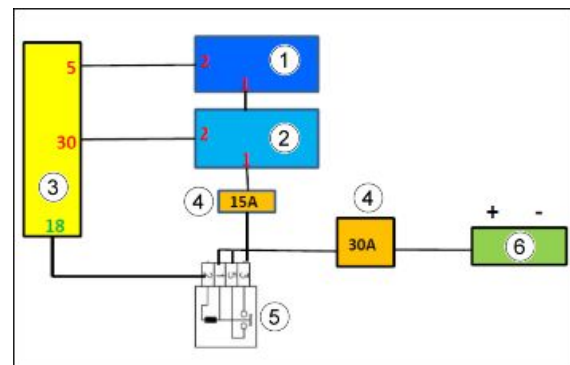

Quick shift

Function:

To indicate to the control unit the request for assisted gear shift.

Operation / Operating principle:

Two normally open switches that are closed to ground when the shift lever is operated (both at upshift and downshift).

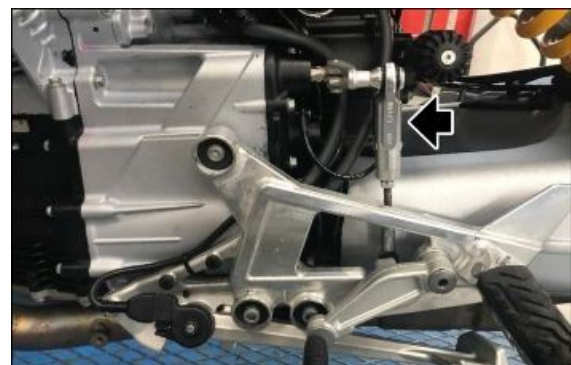

Electrical circuit diagram - Level in electrical circuit diagram:

- Electronic gearbox.

Position:

- On the gearbox lever gear.

Electrical specifications:

- Switch normally open.

Key:

(1) Quick shift

1. Power supply (+ 5 Volt)

2. Signal

3. Ground

(2) 11MP ECU

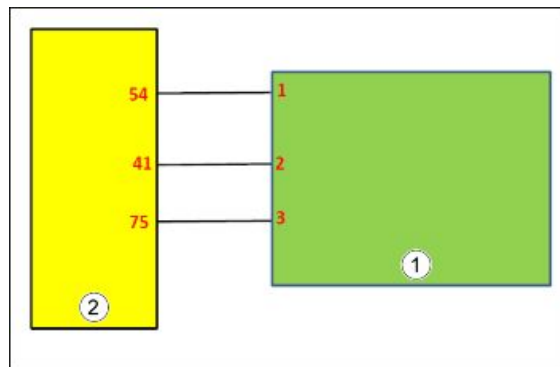

Inertial sensor platform (sensor box)

Level in electrical circuit diagram:

Inertia platform

Position:

- On the rear wheel arch, near the canister

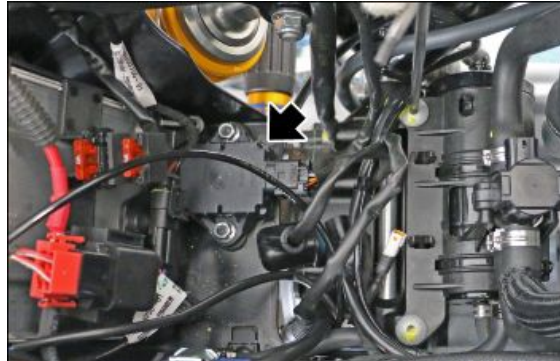

Inertial platform Pin out:

1. Ground

2. CAN line signal_Low

3. CAN line signal_High

4. Fuel system

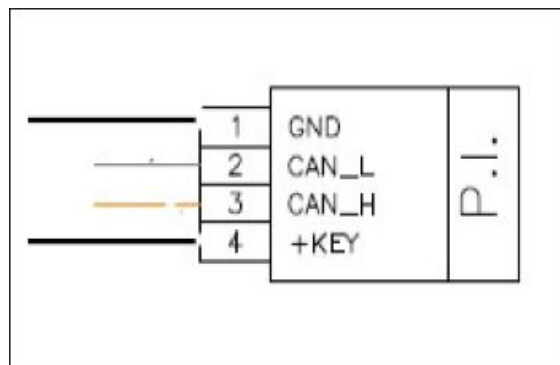

Electrical circuit:

Key:

1. Inertia platform
2. Fuse
3. Ignition switch
4. Main fuse
5. Battery

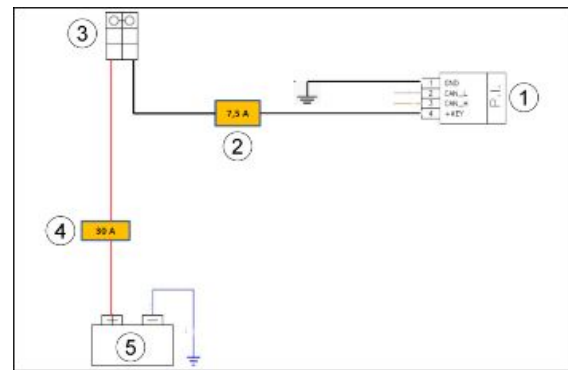
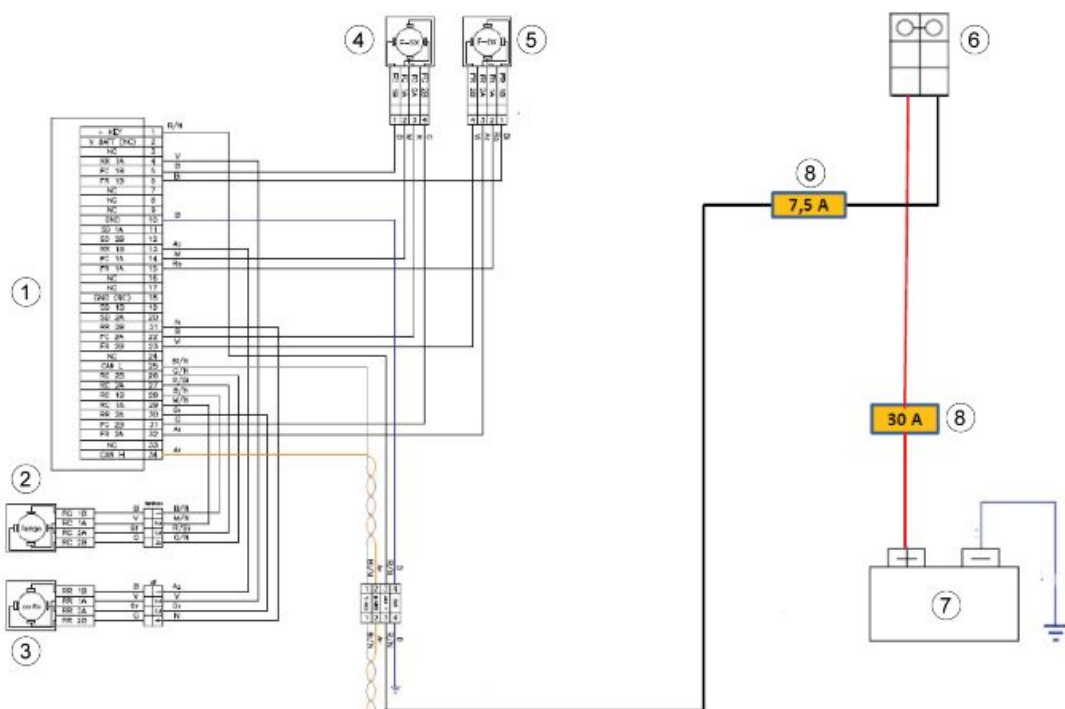
**Suspension valves****SUSPENSION CONTROL UNIT - only V100 Mandello S**

Key:

1. Suspension control unit
2. Rear shock absorber compression adjuster
3. Rear shock absorber extension adjuster
4. Right stanchion compression adjuster
5. Left stanchion extension adjuster
6. Ignition switch
7. Battery
8. Fuse

Can line

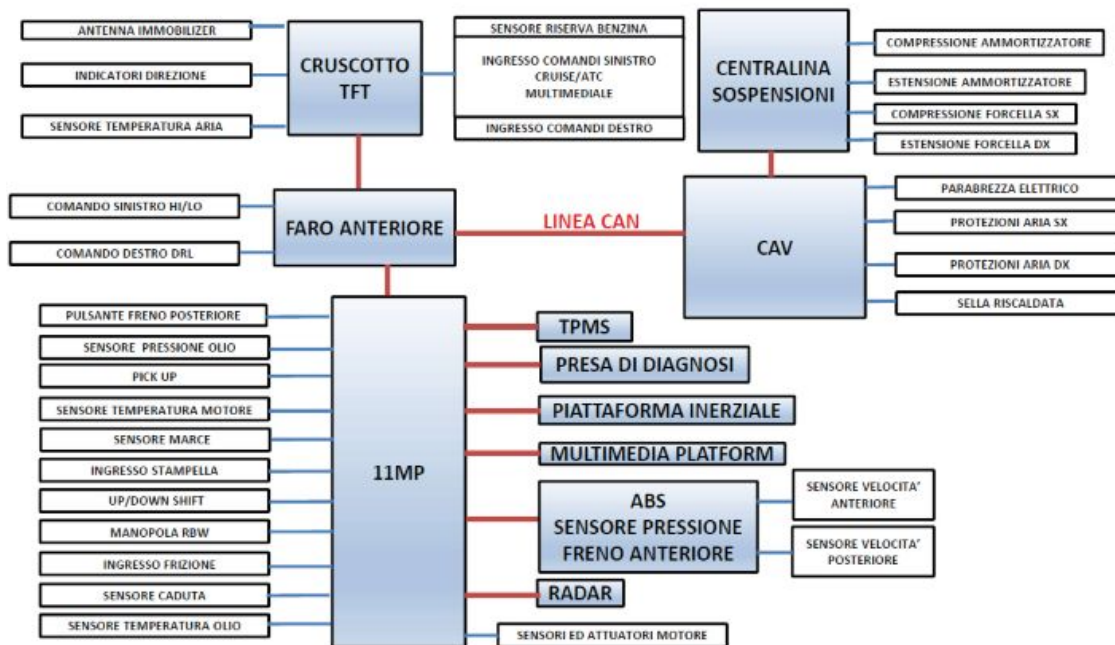

Function

Allows the communication between:

- 11MP ECU;
- TFT instrument cluster;
- Front headlamp;
- Suspension control unit;
- CAV control unit.

Operation / Operating principle

A CAN line (Controller Area Network) is a connection between different electronic devices of a vehicle organised like a computer network (internet). The CAN network significantly simplifies the layout of the electrical system and its overall ground. With this communication line, needless duplication of several sensors present on the motorbike has been obviated. The sensor signals are shared by the two electronic elaboration units (instrument panel and control unit).

- Cable number reduction: The CAN line travels through a twisted cable to several nodes.
- These nodes can also isolate the errors without causing a system breakdown (Faults Confination).
- Immunity to interference: the signal travels through two cables and the signal reading is differential (voltage difference between the two signals on both cables). If the two signals are disturbed by an external factor, their difference remains unaltered.

- Communication speed: messages travel at a speed of 250 kbps (data arrive at nodes every 20 ms, i.e. 50 times/second).

CAN PROTOCOL (CONT. NETWORK AREA)

The communication protocol is CSMA/CD (Carrier Sense Multiple Access w/ Collision Detection).

In order to transmit, every nod must first check that the BUS (the connection among all devices) is free before attempting to send a message with BUS (Carrier Sense).

If during this period there is no activity on BUS, every nod has the same chance to send a message (Multiple Access). If two nodes start transmitting simultaneously, the nodes recognise the "collision" (Collision Detection) and initiate an exchange action based on message priority (messages remain unaltered during exchange and there is no delay for high priority messages).

CAN protocol is based on messages and not on addresses. The message itself is divided into several parts (frames), each of which has a meaning: message priority, data contained, error detection, reception confirmation, etc.

Every network nod receives all the messages sent through the BUS (with reception confirmation or error messages) and each nod decides if the message is to be processed or rejected. Besides, every nod can request information from the other nodes (RTR = Remote Transmit Request).

Level in electrical circuit diagram

- CAN Line

Electrical specifications

- All the control units connected: Electrical resistance value, when measured between pins 1 and 2 of the OBD port = 60 ± 6 Ohm
- Only instrument cluster disconnected: Electrical resistance value, when measured between pins 1 and 2 of the OBD port = 120 ± 12 Ohm
- Only 11MP control unit disconnected: Electrical resistance value, when measured between pins 1 and 2 of the OBD port = 120 ± 12 Ohm

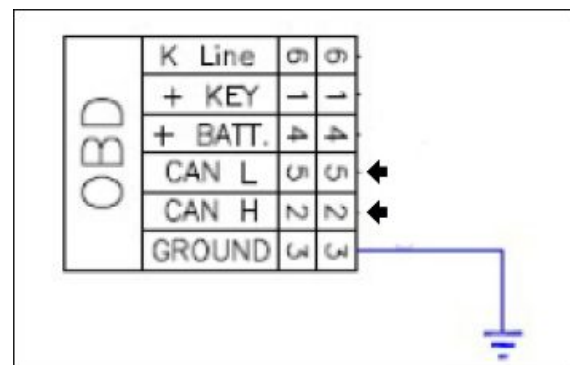

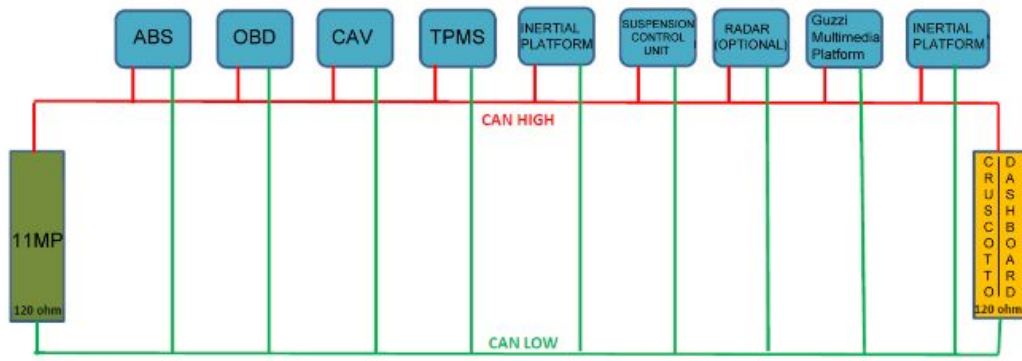

INDEX OF TOPICS

ENGINE FROM VEHICLE

ENG VE

Vehicle preparation

CAUTION



TO CARRY OUT THE MAINTENANCE OPERATIONS AND IF THERE IS THE NEED TO RAISE THE VEHICLE, USE A PANTOGRAPH LIFT PLACED IN CORRESPONDENCE WITH THE OIL SUMP. IN ORDER TO AVOID DAMAGES, PLACE A PROTECTION BETWEEN THE OIL SUMP AND THE LIFT.

To remove the engine from the vehicle, first perform the following operations:

- Place a pantograph jack under the engine and support the rear part of the vehicle with a suitable stand or a workshop lift. Check the stability of the vehicle to prevent it from falling and causing personal injuries.
- Disconnect the battery and remove: the radiator, fuel tank, air filter housing, swingarm, cardan shaft, ECU.
- Remove the clutch actuator and the rear shock absorber preload adjuster from the clutch crankcase.

Removing the engine from the vehicle

- Cut the tape fastening the engine wiring harness to the frame.

NOTE

During refitting, you can use plastic clamps to secure the wiring harness in position.

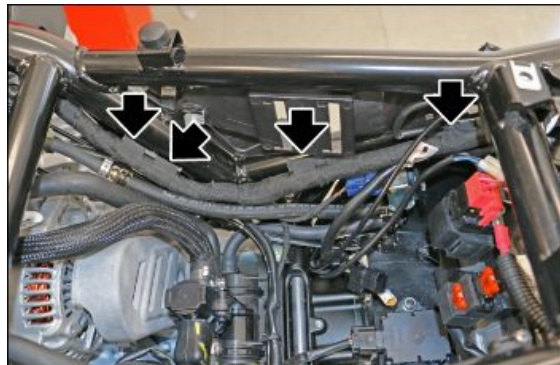

- Pass the wiring harness under the frame pipe.



- Remove the connector (1) from its retainer on the internal side of the rear wheel housing and disconnect it.

CAUTION

MAKE SURE TO RECONNECT THE CONNECTOR (1) DURING REFITTING, OTHERWISE IT WILL NOT BE POSSIBLE TO START THE ENGINE.



- Cut the clamp (2).



- Disconnect the water temperature sensor (3).



- Remove from the canister support the wiring harnesses indicated in the figure.

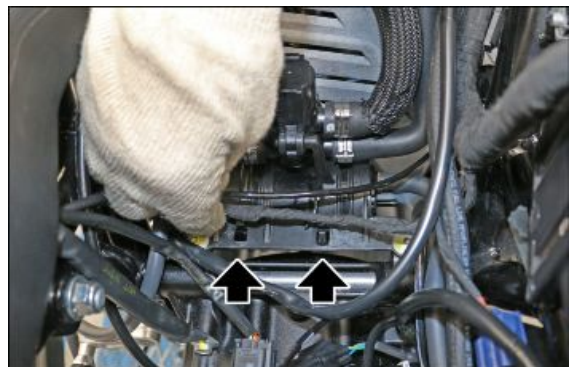

- Unscrew the fixing nut (4) and remove the PURGE valve from its support.



- Unscrew the fixing nut (5) of the engine ground cable.



- Unscrew the fixing nut of the rear brake hose clamp.

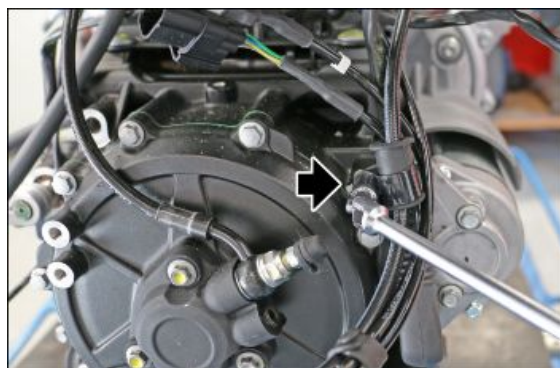

- Remove the protective cap (6).
- Remove the fixing nut (7) of the starter motor supply cable, then remove the cable from the starter motor.



- Cut the plastic clamp shown in the figure, on both sides of the vehicle.



- Remove the 4 cable gland clips and remove the side covers of the radiator.
- Repeat on the opposite side.

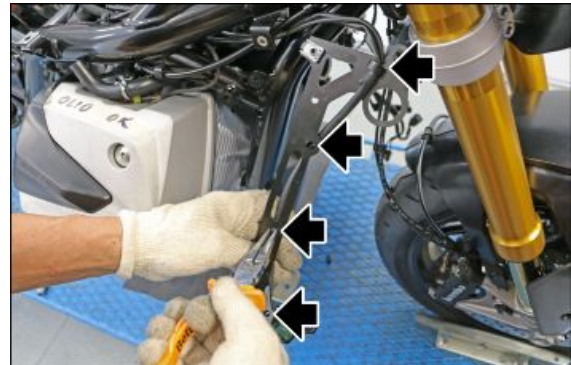

- Pass the wiring harnesses through the frame to prevent them from getting damaged during the engine removal. On both sides.



- Unscrew the three fixing screws (8) of the head support (9).

During refitting, tighten the fixing screws to the prescribed torque.

Locking torques (N*m)

Head support fixing screw $50 \pm 7.5 \text{ Nm}$ ($36.88 \pm 5.53 \text{ lb ft}$)



- Remove the head support bracket (9) from the frame.



Repeat the removal operations for the bracket on the opposite side.

- Remove the screws fixing the engine to the front frame.



During refitting, tighten the fixing screws to the prescribed torque.

Locking torques (N*m)

Screw fixing the engine to the frame $50 \pm 7.5 \text{ Nm}$ ($36.88 \pm 5.53 \text{ lb ft}$)

- Remove the lock nut of the engine support pin.



During refitting, tighten the lock nut to the prescribed torque.

Locking torques (N*m)

Engine pin lock nut $86 \pm 13 \text{ Nm}$ ($63.43 \pm 9.59 \text{ lb ft}$)

- Remove the engine support pin from the left side of the vehicle.

CAUTION



MAKE SURE THE ENGINE AND THE FRAME ARE STABLE.



- Remove the engine from the frame by pulling downward. Take extra care not to damage any components during removal.

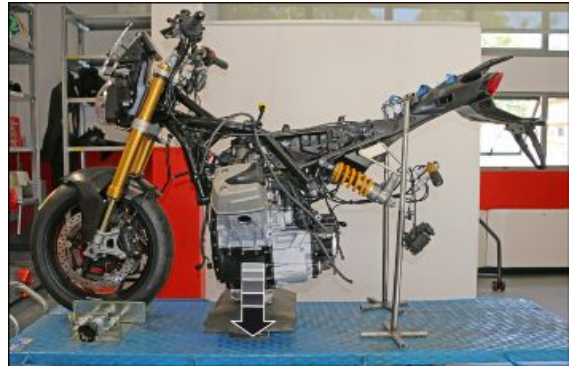

INDEX OF TOPICS

ENGINE

ENG

TO CONSULT THE CHAPTER ABOUT THE ENGINE AND ITS COMPONENTS PLEASE REFER TO THE APPROPRIATE MANUAL: "MSS Engine Guzzi V100"

INDEX OF TOPICS

POWER SUPPLY

P SUPP

Fuel pump

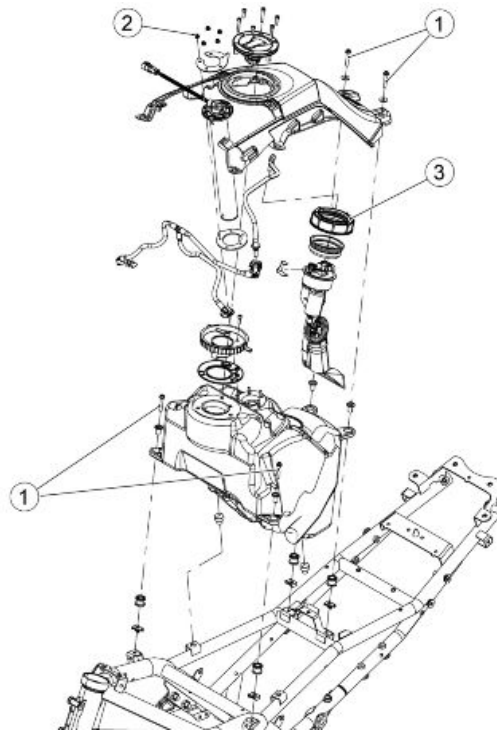

FUEL TANK

Pos.	Description	Type	Quantity	Torque	Notes
1	Screws fastening the fuel tank to frame	M6	4	10 Nm (7.38 lbf ft)	-
2	Ring nut fastening the fuel pump to the fuel tank	-	1	20 Nm (14.75 lbf ft)	-
3	Nuts fixing the fuel level probe to the fuel tank	M4	5	1 Nm (0.74 lb ft)	-

Removing

NOTE

The fuel pump can be removed even if the tank is mounted on the vehicle. The procedure is the same as that described below, just remove the tank cover.

- Disconnect the connector of the fuel pump's wiring harness.



- Remove the safety tab (1) from the fuel pipe.



- Press the external ring (2) and remove the pipe (3) from the fuel pump.



- Unscrew and remove the ring nut from the tank.



- Extract the pump from the tank and retrieve the gasket (4).

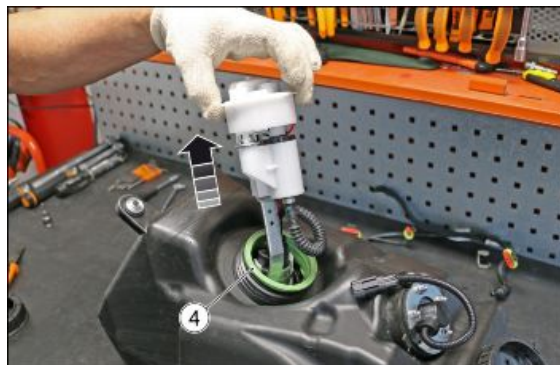

CAUTION

During refitting, the pump connector must be turned toward the rear side of the tank.

**Injection****Removing the throttle body**

To access the throttle bodies, the battery must be disconnected and the following components removed:

- top fairing
- front fairing cover
- left and right side fairing
- tank cover
- fuel tank
- Air filter box



Unscrew the fixing screw of the pipe metal retaining clamp to the fuel tank.

Remove the fixing screw of the metal retaining clamp.



Unscrew the right intake duct fixing screws.



Remove the right intake duct.



Unscrew the left intake duct fixing screws.



Remove the left intake duct.

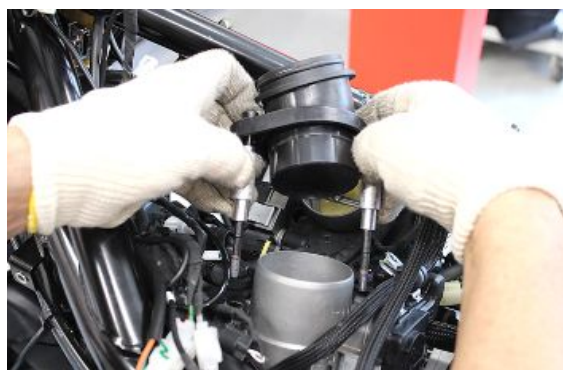

Disconnect the two throttle body ECU connectors by pulling the relative tab.

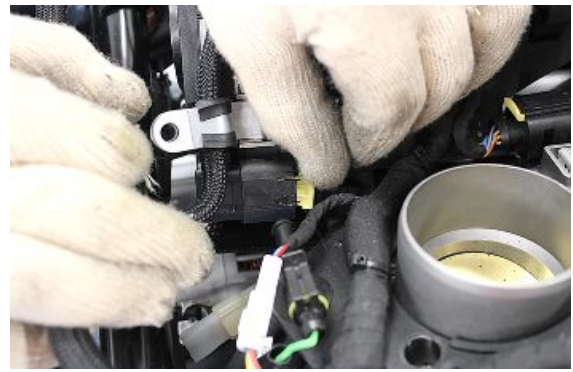

Disconnect the two throttle body ECU connectors.



Perform the following operations for both throttle bodies.

Loosen the throttle body retaining calmp from the engine sleeve.



Lift up the throttle body and remove the retaining calmp.



Disconnect the air temperature/pressure sensor connector.



Remove the vacuum hose.



Remove the throttle body.



Installing the throttle body

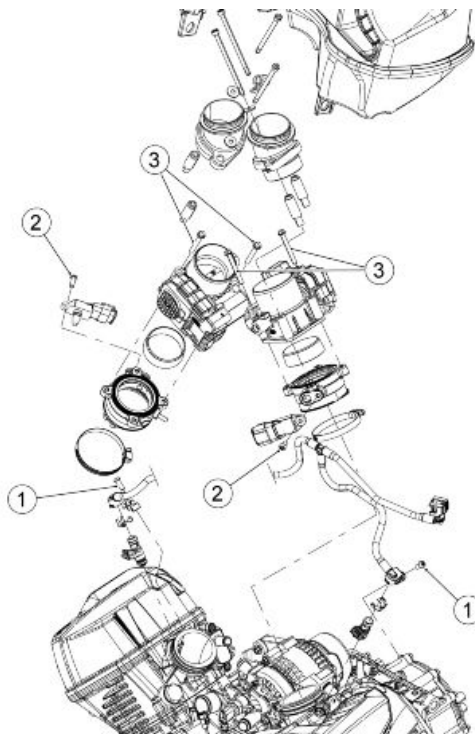

THROTTLE BODIES

Pos.	Description	Type	Quantity	Torque	Note
1	Injector mounting fixing screw	M6	2	11 ÷ 13 Nm (8.11 ÷ 9.59 lbf ft)	-
2	Air temperature/pressure sensor fastening screw	M6	2	11 ÷ 13 Nm (8.11 ÷ 9.59 lbf ft)	-
3	Throttle body fastening screw	M6	4	9 ÷ 11 Nm (6.64 ÷ 8.11 lbf ft)	-

Perform the following operations for both throttle bodies.

Position the throttle body near the engine sleeve.



Insert the vacuum tube.



Connect the air temperature/pressure sensor connector.



Place the throttle body retaining calmp on the engine sleeve.

Insert the throttle body on the engine sleeve.



Screw the throttle body retaining calmp to the engine sleeve.



Connect the two throttle body ECU connectors by locking them with the appropriate tab.

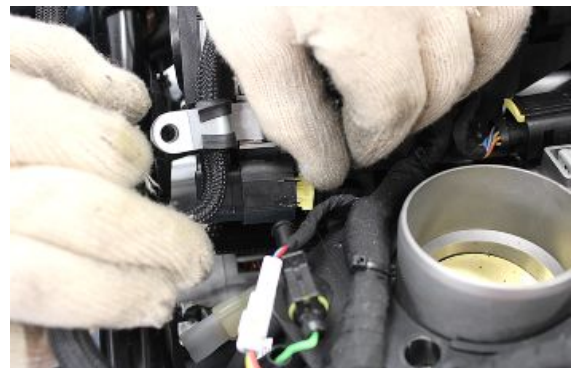

Position the intake ducts on the throttle bodies.



Tighten intake duct fixing screws.



Screw in the fixing screw of the pipe metal retaining clamp to the fuel tank.

Proceed to reassemble the following components:

- Air filter box
- fuel tank
- tank cover
- left and right side fairing
- front fairing cover
- top fairing
- Reconnect the battery.



INDEX OF TOPICS

SUSPENSIONS

SUSP

Front

Handlebar

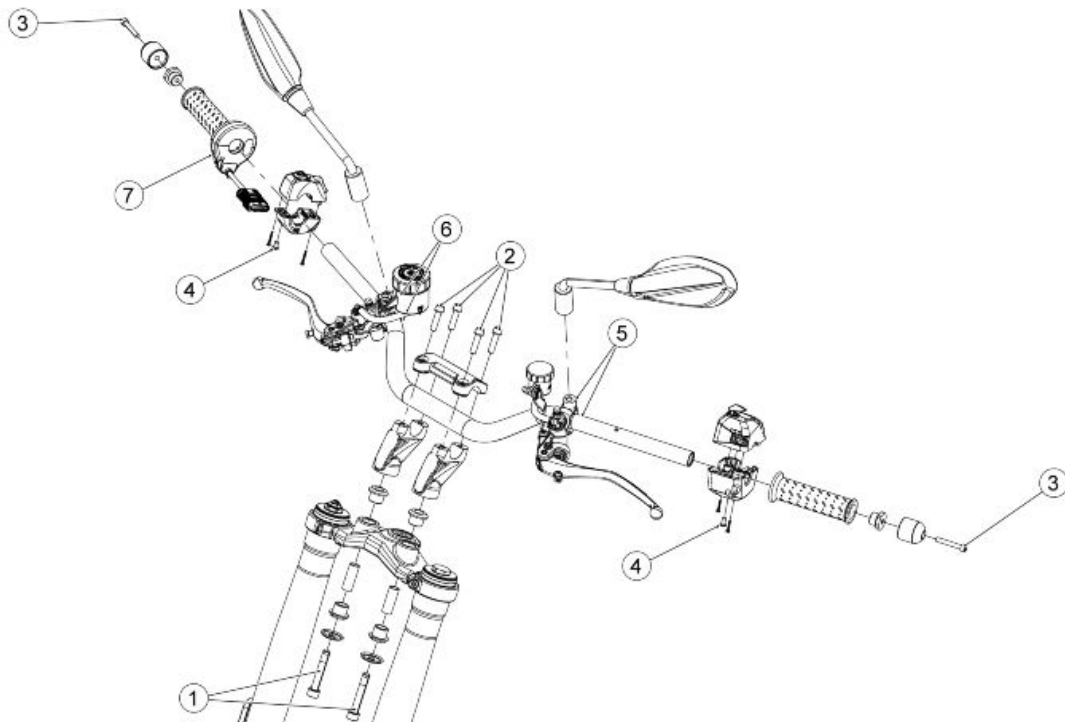

HANDLEBAR-CONTROLS

Pos.	Description	Type	Quantity	Torque	Notes
1	Screws fastening the lower U-bolts to the upper steering yoke	M10	2	50 Nm (36.88 lbf ft)	Loctite 243
2	Screws fastening the lower U-bolt clamp to the handlebar	M8	4	25 Nm (18.44 lbf ft)	-
3	Screws fastening the anti-vibration weights to the handlebar	M6	1+1	10 Nm (7.38 lbf ft)	-
4	Screws fastening the light switch to handlebar	M5	1+1	4 Nm (2.95 lbf ft)	Pre-fitted on the light switch
5	Clutch pump U-bolt fastening screws	M6	2	10 Nm (7.38 lbf ft)	-
6	Front brake master cylinder U-bolt fixing screws	M6	2	10 Nm (7.38 lbf ft)	-
7	Screw fastening the electronic throttle control to handlebar	M4	1	4 Nm (1.62 lbf ft)	Pre-fitted on the throttle control

Removing

- First remove the rear-view mirrors.
- Remove the anti-vibration weight from the handlebar, on both sides.

During refitting, tighten the anti-vibration weight to the prescribed torque.

Locking torques (N*m)

**Screw fastening the anti-vibration weight 10 Nm
(7.38 lbf ft)**



- Remove the threaded bushing from the handlebar, on both sides.



- Release the wiring harnesses from the cable gland on the right stanchion.



- Open the rubber clamp.



- Loosen the screw fastening the throttle control.



- Remove the throttle control from the handlebar and place it on the vehicle, taking care not to damage the body-work.



WARNING



It is not possible to replace only the throttle control grip as it is integrated with the throttle control. If necessary, you must replace the throttle control unit.

- Loosen the screw fastening the right switch.



- Slide the switch off the handlebar, paying attention to the throttle control, the wiring harnesses are secured together with clamps.



- Support the front brake pump and unscrew the two fixing screws (1) of the fixing U-bolt (2).



- Remove the front brake pump from the handlebar and place it on the tank, taking care not to tension the pipe or damage the bodywork.



- Remove the rubber clamp from the left side wiring harnesses.



- Remove the screw (3) fixing the top of the left handle.



- Remove the lower fixing screw (4) of the left knob.



- Remove the left hand handle from the handlebar and place it on the vehicle, taking care not to damage the bodywork.



DURING REFITTING, MAKE SURE TO INSERT THE FIXING SCREWS OF THE HANDLE IN THE RELEVANT THREADED HOLES OF THE HANDLEBAR.



- Release the wiring harnesses from the cable gland on the left stanchion.



- Loosen the fixing screw (6) of the left light switch and remove it from the handlebar; place it on the vehicle, taking care not to damage the bodywork.



- Support the clutch pump and unscrew the two screws (7) of the fixing U-bolt (8).



- Remove the clutch pump from the handlebar and place it on the tank, taking care not to tension the pipe or damage the bodywork.



- Unscrew the four fixing screws (9) of the handlebar.

During refitting, first tighten the front fixing screws and then the rear, all to the prescribed torque.

Locking torques (N*m)

Handlebar fixing screw 25 Nm (14.44 lbf ft)



- Remove the U-bolt (10) of the handlebar, then remove the handlebar itself from the vehicle.

CAUTION

ALWAYS REPLACE A DAMAGED AND/OR BENT HANDLEBAR AS ITS STRUCTURAL STRENGTH IS COMPROMISED. NEVER ATTEMPT TO READJUST A BENT HANDLEBAR, EVEN IF IT IS ONLY SLIGHTLY BENT.



Front fork

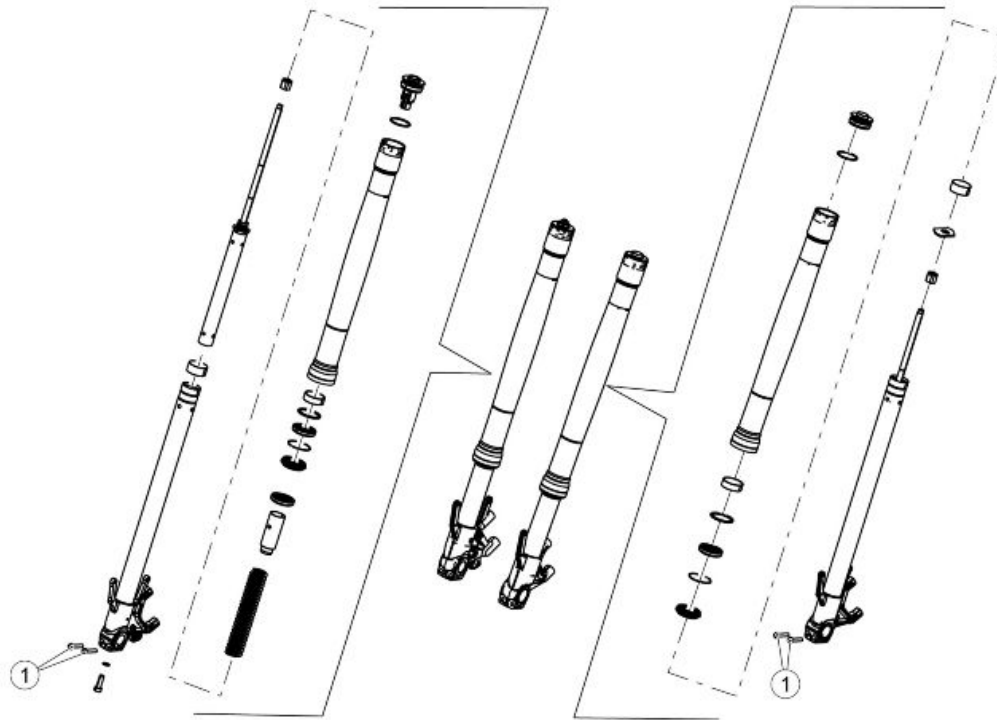

FRONT FORK

Pos.	Description	Type	Quantity	Torque	Notes
1	Screws fastening the calliper mounting bracket to the wheel axle	M6	4	10 ± 1.5 Nm (7.38 ± 1.10 lb ft)	-

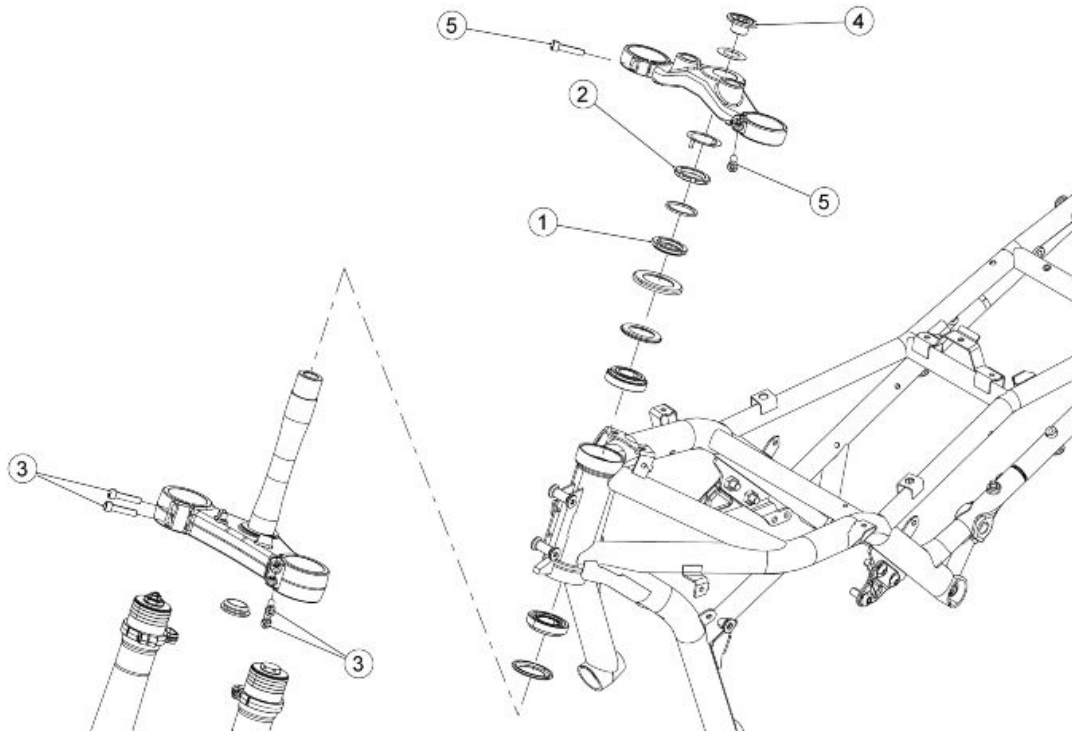

STEERING

Pos.	Description	Type	Quantity	Torque	Notes
1	Ring nut fastening the bottom yoke/steering pin assembly to the headstock	-	1	-	First tightening torque 60 Nm (44.25 lbf ft) - Second tightening torque 30 Nm +/- 5 Nm (22.13 +/- 3.69 lbf ft)
2	Counter-lock ring fastening the bottom yoke/steering pin assembly to the headstock	-	1	-	Manual
3	Screw fastening the fork stanchions to the lower steering yoke	M8	4	25 Nm (18.44 lbf ft)	-
4	Top steering yoke fastener bush	-	1	100 Nm (73.76 lbf ft)	-
5	Screw fastening the fork stanchions to the upper steering yoke	M8	2	25 Nm (18.44 lbf ft)	-

Removing the fork legs

- To remove the front fork, install a workshop stand to the rear wheel and place a pantograph jack under the engine to lift the front wheel off the ground. Check the stability of the vehicle.
- First remove the side fairings, the front mudguard, the brake callipers and the front wheel.
- Only for OHLINS fork: Disconnect the connectors of the sensors on the stanchion caps.



To avoid damaging the vehicle, place a protection between the jack and the sump oil.

- Disconnect the connector (1) from both stanchion caps.

NOTE

Operation necessary only for OHLINS forks .



- Loosen the cable gland clamp from the fork stanchion.



- Loosen the screw (2) of the upper steering plate.

During refitting, tighten the screw to the prescribed torque.

Locking torques (N*m)

Upper steering plate screw 25 ± 2.5 Nm (18.44 ± 1.84 lbf ft)



- Support the fork stanchion and loosen the two screws (3) of the lower steering plate.

During refitting, tighten the screws to the prescribed torque.

Locking torques (N*m)

Lower steering plate screw 25 ± 2.5 Nm (18.44 ± 1.84 lbf ft)



- Slide off the stanchion downward and remove it from the vehicle.
- Repeat the operation for the stem on the opposite side.



INSTALLATION

- Follow the removal procedure in reverse order; be careful to tighten the retainers to the specified tightening torques.

NOTE

DURING REFITTING, INSERT THE FORK STANCHIONS IN THE STEERING PLATES SO AS TO OBTAIN 12 mm BETWEEN THE UPPER STEERING PLATE AND THE UPPER EDGE OF THE FORK STANCHION (MEASURED UNDER THE SLEEVE CAP).

**Draining oil****V100 Mandello S****NOTE**

THE FOLLOWING OPERATIONS ARE FOR OHLINS FORKS WITH ELECTRONIC ADJUSTMENTS.

- Set the pre-loading spring to the minimum position.



- Unscrew the upper cap from the sleeve using a specific Öhlins tool.

Specific tooling

01761-04 Öhlins fork cap ring nut



- Loosen the cap using a wrench in order to release the upper nut on the spring retaining ring.
- Unscrew the upper adjustment cap using the special Ohlins tool.

Specific tooling

01761-04 Ohlins fork cap ring nut



- Remove the complete cap.



- Unscrew the nut and remove it, exerting slight pressure on the pre-loading spring.



- Remove the pre-loading spring retaining ring.

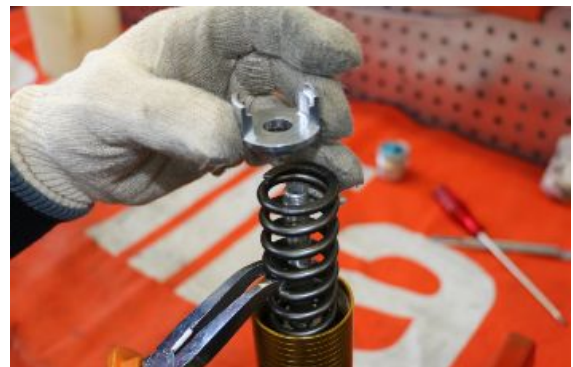

- Remove the pre-loading spring.



- Empty the fork oil into a special container, taking care not to let the pre-loading tube come out.



Disassembling the fork

V100 Mandello

NOTE

THE FOLLOWING OPERATIONS REFER TO THE KAYABA FORKS WITH MECHANICAL ADJUSTMENTS.

NOTE

THE STEMS ARE NOT THE SAME, THEREFORE THEY REQUIRE SEPARATE REMOVAL PROCEDURES.

THE FOLLOWING OPERATIONS APPLY WHEN REMOVING THE RIGHT HAND STEM

- Taking care not to damage it, secure the fork vertically in a vice, using the appropriate protection devices.
- Unscrew the upper cap (1).

Specific tooling

AP8140149 Guard for assembly operations



- Using the special tool (2), fastened to the pre-loading pipe (3), compress the spring and, with the assistance of a second operator, insert the separator plate (4) under the cap retaining nut (5).

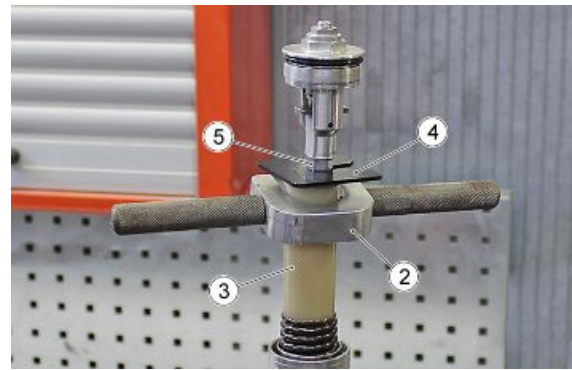

Specific tooling

020888Y Pre-load tube clamp

AP8140148 Plunger-spacer separator plate

- Ensure that the cap (1) cannot rotate, and then loosen the nut (5).



- Unscrew and remove the cap (1).



- Extract the shaft (6) and remove it.



- After removing the locking plate and the device used to compress the spring, remove the upper plate (7) and the pre-loading pipe (3).

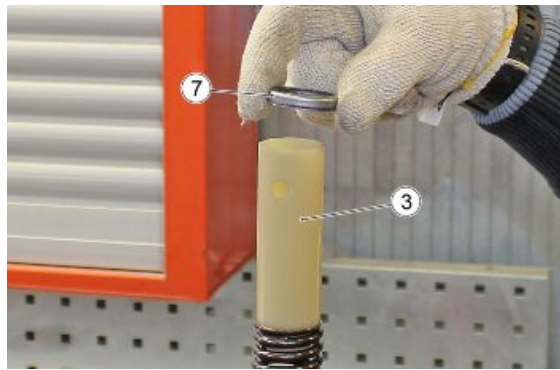

- Remove the spring (8) allowing the oil inside the stem to drip out.

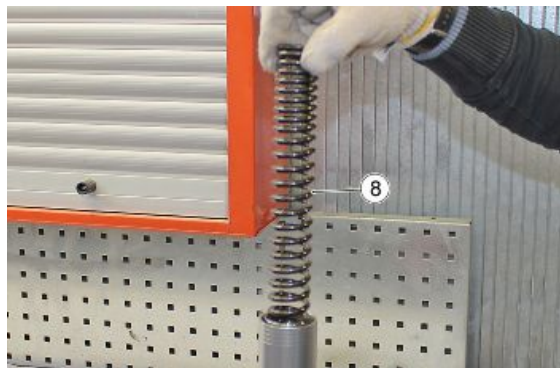

- Drain the oil into a container having sufficient capacity, extending the stanchion several times in order to ensure the oil is drained completely.

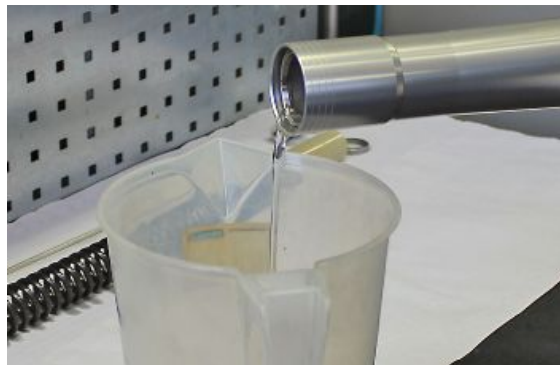

DO NOT DISPOSE OF OIL IN THE ENVIRONMENT. DISPOSE OF ENGINE OIL IN A SEALED CONTAINER AND TAKE IT TO YOUR SUPPLIER OR TO THE NEAREST USED OIL COLLECTION CENTRE.

- Taking care not to damage it, secure the sleeve horizontally in a vice, using the appropriate protection devices.
- Extract the dust guard (9).

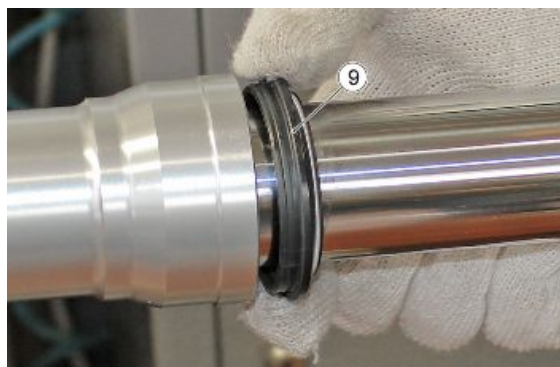

Specific tooling

AP8140149 Guard for assembly operations

- Remove the seeger ring (10) from inside the sleeve.

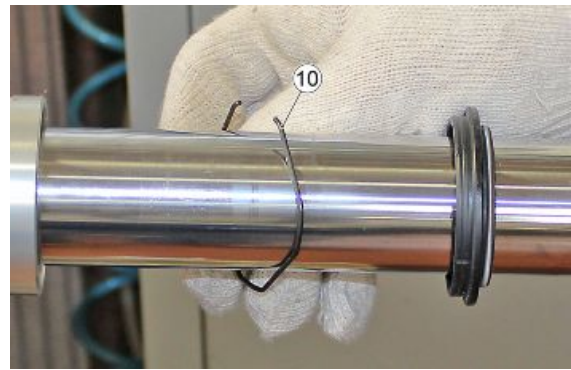

- Pull the stem repeatedly towards yourself in order to remove it from the sleeve.

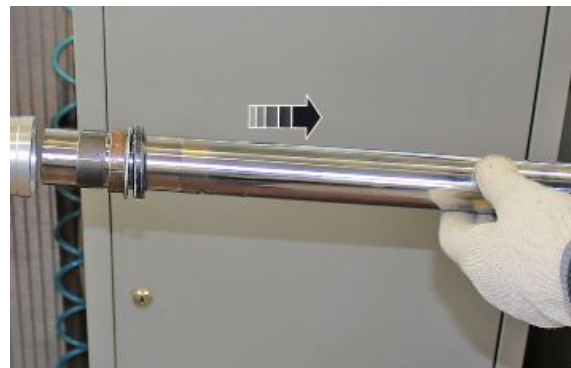

- Secure the stem in a vice and remove the plunger fastening screw (11), taking care not to lose the copper washer (12).



- Remove the complete plunger (13).

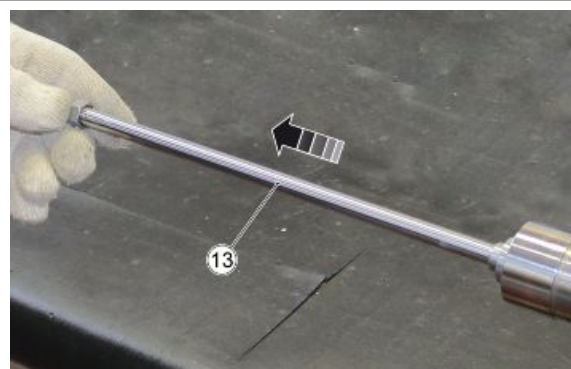

- Observing the indicated sequence, extract and remove the slider bushing (14), the guide bushing (15), the ring (16), the oil seal (17), the seeger ring (10) and the dust guard (9).

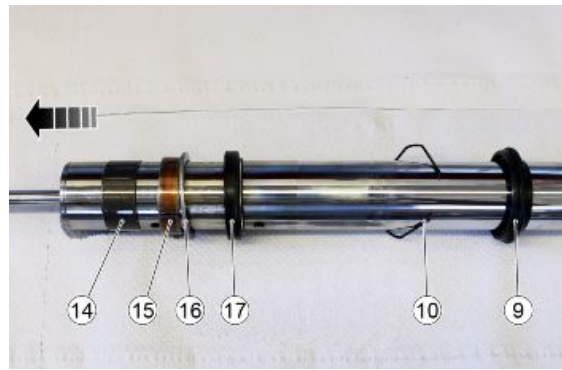

THE FOLLOWING OPERATIONS APPLY WHEN REMOVING THE RIGHT HAND STEM

- Taking care not to damage it, secure the fork vertically in a vice, using the appropriate protection devices.
- Unscrew the upper cap (1).



Specific tooling

AP8140149 Guard for assembly operations

- Ensure that the cap (1) cannot rotate, and then loosen the special nut (2).

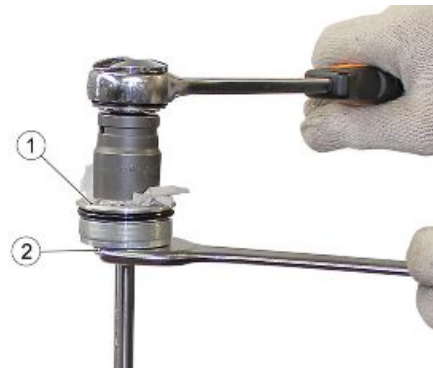

- Unscrew and remove the cap (1).



- Unscrew the special nut (2) and remove it.



- Remove the buffer (3).

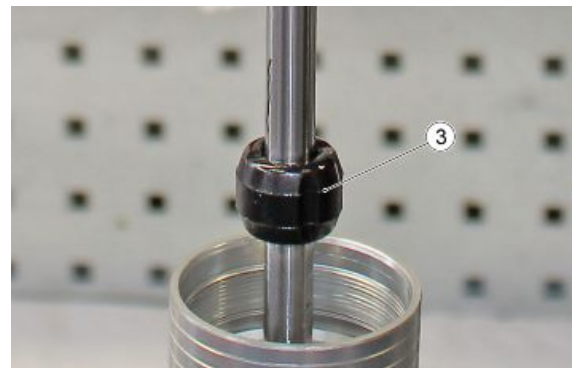

- Drain the oil into a container having sufficient capacity, extending the station several times in order to ensure the oil is drained completely.



DO NOT DISPOSE OF OIL IN THE ENVIRONMENT. DISPOSE OF ENGINE OIL IN A SEALED CONTAINER AND TAKE IT TO YOUR SUPPLIER OR TO THE NEAREST USED OIL COLLECTION CENTRE.



- Taking care not to damage it, secure the sleeve horizontally in a vice, using the appropriate protection devices.
- Extract the dust guard (4).

Specific tooling

AP8140149 Guard for assembly operations

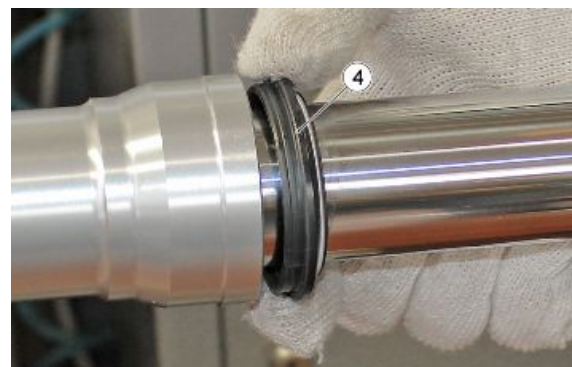

- Remove the seeger ring (5) from inside the sleeve.

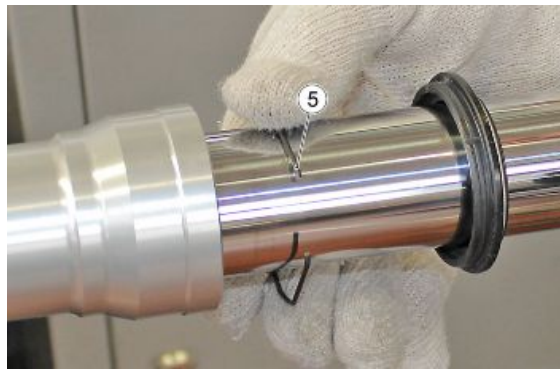

- Pull the stem repeatedly towards yourself in order to remove it from the sleeve.



- Observing the indicated sequence, extract and remove the slider bushing (6), the guide bushing (7), the ring (8), the oil seal (9), the seeger ring (5) and the dust guard (4).

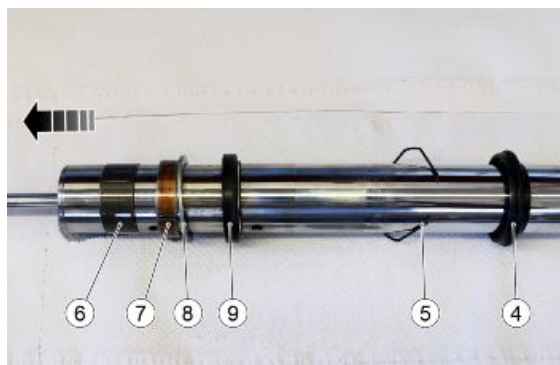

V100 Mandello S

NOTE

THE FOLLOWING OPERATIONS ARE FOR OHLINS FORKS WITH ELECTRONIC ADJUSTMENTS.

- Remove the pre-loading tube.



- Remove the wheel holder shaft (1) and the sleeve (2).



- Clamp the sleeve in a vice and, by levering it alternately at various points, remove the anti-dust seal (3) from the sleeve (2).



- Remove the retaining ring (4).

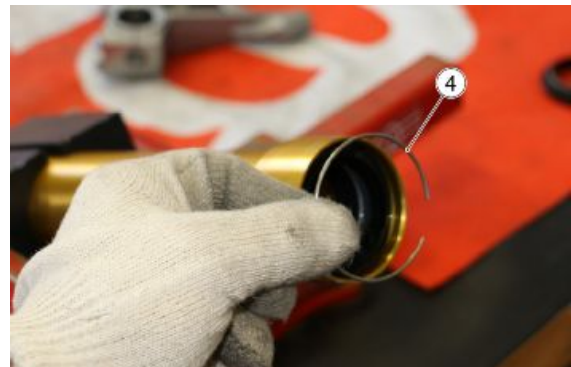

- Remove the shaft seal (5) by levering it alternately at various points.

CAUTION

PROTECT THE EDGE OF THE SLEEVE IN ORDER TO AVOID RUINING IT WHILE REMOVING THE SHAFT SEAL (5).



Replace the following components with new ones:

- shaft seal (5)
- anti-dust seal (3)

CAUTION

PROCEED WITH EXTREME CAUTION IN ORDER TO PREVENT FOREIGN BODIES FROM ENTERING THE SLEEVE OR THE WHEEL HOLDER SHAFT. DO NOT REUSE THE OIL THAT WAS DRAINED EARLIER

Checking the components

V100 Mandello

NOTE

THE FOLLOWING OPERATIONS REFER TO THE KAYABA FORKS WITH MECHANICAL ADJUSTMENTS.

stanchion

Check that the sliding surface is not scratched or scored.

Any scoring can be removed by sanding with damp sandpaper (grain 1).

If the scratches are deep, replace the stanchion .

Using a dial gauge, check than any bending of the stanchion is below the limit value.

If it is over the limit, replace the stanchion .

CAUTION

A BENT STANCHION SHOULD NEVER BE STRAIGHTENED SINCE ITS STRUCTURE WOULD BE WEAKENED MAKING THE VEHICLE DANGEROUS TO USE.

Characteristic

Bending limit:

0.2 mm (0.00787 in)

Sleeve

Check for damage and/or cracks; if it is damaged, replace it.

Spring

Check for damage and/or cracks; If it is damaged, replace it.

Check the condition of the following components:

- slider bushing;
- guide bushing;
- plunger.

If there is evidence of excessive wear or damage, replace the component concerned.

CAUTION

REMOVE ANY IMPURITIES FROM THE BUSHINGS, BEING CAREFUL NOT TO SCRATCH THEIR SURFACES.

Replace the following components with new ones:

- Oil seal.
 - Dust guard.
 - - O-ring on the cap.
-

V100 Mandello S

NOTE

THE FOLLOWING OPERATIONS ARE FOR OHLINS FORKS WITH ELECTRONIC ADJUSTMENTS.

stanchion

Check that the sliding surface is not scratched or scored.

Any scoring can be removed by sanding with damp sandpaper (grain 1).

If the scratches are deep, replace the stanchion .

Using a dial gauge, check than any bending of the stanchion is below the limit value.

If it is over the limit, replace the stanchion .

CAUTION

A BENT STANCHION SHOULD NEVER BE STRAIGHTENED SINCE ITS STRUCTURE WOULD BE WEAKENED MAKING THE VEHICLE DANGEROUS TO USE.

Characteristic**Bending limit:**

0.2 mm (0.00787 in)

Sleeve

Check for damage and/or cracks; if it is damaged, replace it.

Spring

Check for damage and/or cracks; If it is damaged, replace it.

Reassembling the fork**V100 Mandello****NOTE**

THE FOLLOWING OPERATIONS REFER TO THE KAYABA FORKS WITH MECHANICAL ADJUSTMENTS.

CAUTION

THE STEMS ARE NOT THE SAME, THEREFORE THEY REQUIRE SEPARATE MOUNTING PROCEDURES.

THE FOLLOWING OPERATIONS APPLY WHEN MOUNTING THE RIGHT HAND STEM.

- Observing the indicated sequence, extract and remove the dust guard (1), the seeger ring (2), the oil seal (3), the ring (4), the guide bushing (5) and the slider bushing (6).

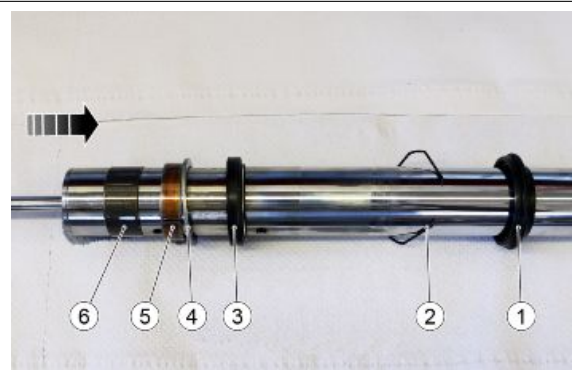

- Insert the complete plunger (7).

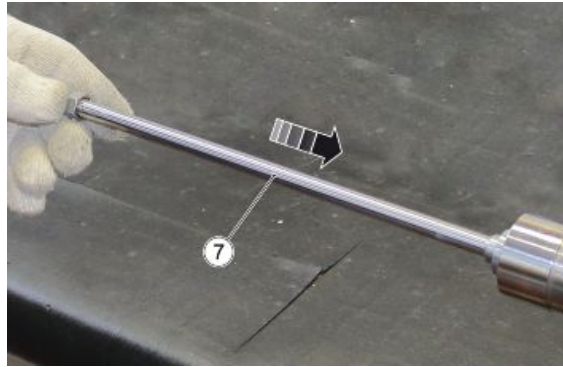

- Secure the stem in a vice and, after inserting the screw (8) used to fasten the plunger, complete with the copper washer (9), apply the pre-defined tightening torque.



- - Insert the stem in the sleeve.

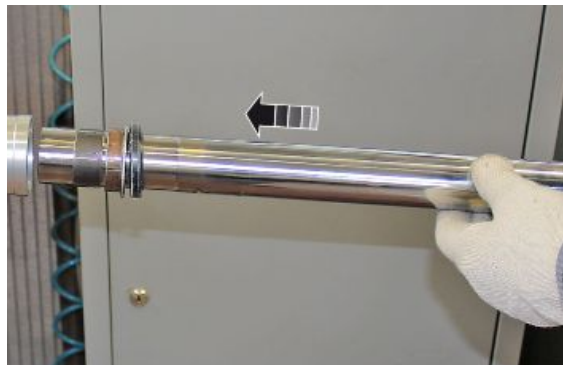

- Using a suitable tool, complete with striking hammer, insert oil seal into its housing (3).

Specific tooling

AP8140189 Tool for fitting oil seal for 43 mm (1.69 in) diameter hole

AP8140146 Weight

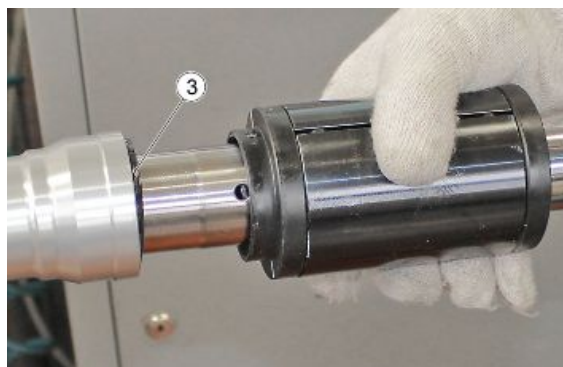

- Position the seeger ring (2) inside the sleeve.

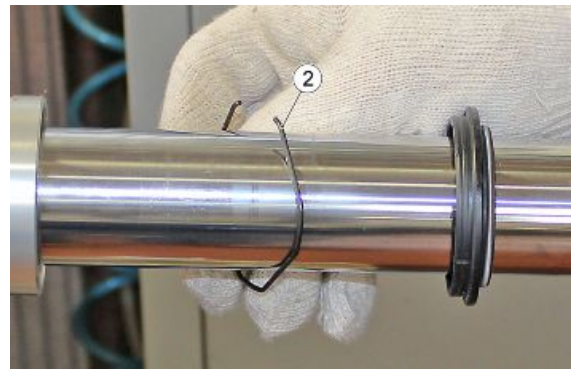

- Insert the dust guard (1) into its housing correctly.

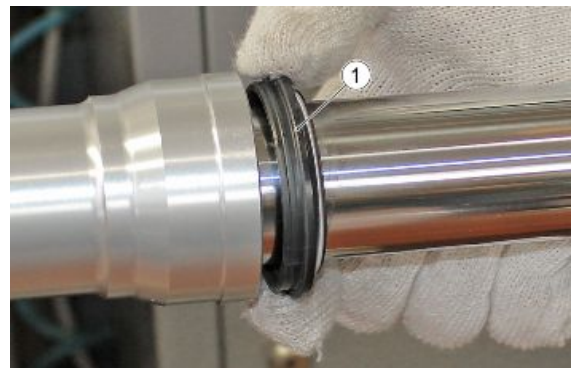

- Place the fork stem vertically on a work surface.
- Fill the stem with the quantity of oil indicated in the "Refilling oil" section.



- Insert the spring (10), making sure that it is aligned correctly. The end where the spirals are more compressed should be facing upwards.

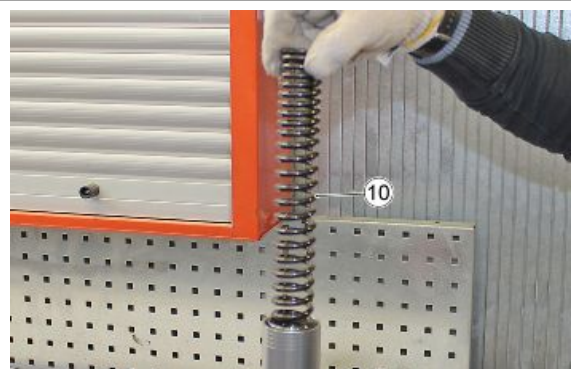

- Insert the pre-load tube (11), making sure that it is aligned correctly. The narrower part must be inserted into the spring.

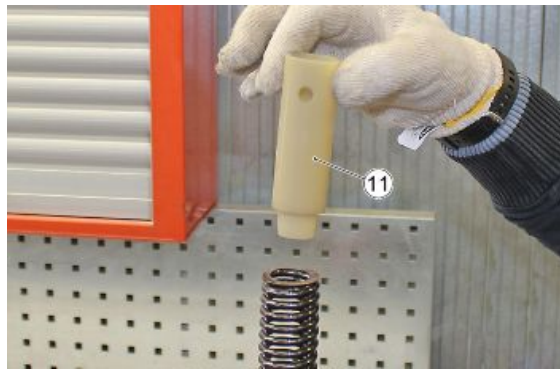

- Insert the upper plate (12) on the pre-load pipe



- After positioning the device (13) on the pre-load pipe (11) and the plunger support shaft (14), with the assistance of a second operator, raise the plunger so that it is possible to insert the plate (15) under the cap locking nut.



Specific tooling

020888S Pre-load tube clamp

AP8140150 Bored shaft for bleeding plunger air

AP8140148 Plunger-spacer separator plate

- Insert the shaft (16) into the plunger.



- Before positioning the cap, adjust the hydraulic regulator screw so that the internal distance is as close as possible to 13 mm (0.51 in).



- Screw the cap (17) onto the plunger as far as it will go.

CAUTION

CHECK THE O-RING PRESENT ON THE FILLING CAP AND REPLACE IF DAMAGED.



- Ensure that the cap cannot rotate, and then tighten the nut.



- Tighten the cap on the sleeve, applying the pre-defined torque.



THE FOLLOWING OPERATIONS APPLY WHEN MOUNTING THE LEFT HAND STEM

- Observing the indicated sequence, extract and remove the dust guard (1), the seeger ring (2), the oil seal (3), the ring (4), the guide bushing (5) and the slider bushing (6).

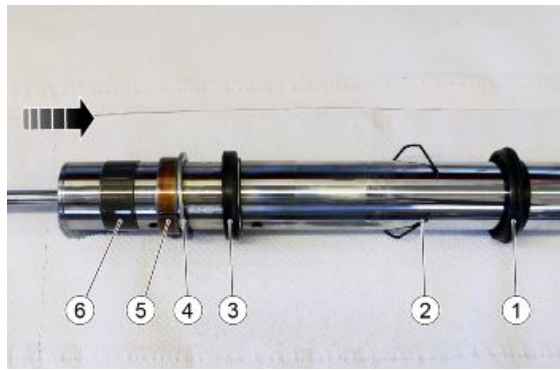

- - Insert the stem in the sleeve.



- Using a suitable tool, complete with striking hammer, insert oil seal into its housing (3).

Specific tooling

AP8140189 Tool for fitting oil seal for 43 mm (1.69 in) diameter hole

AP8140146 Weight

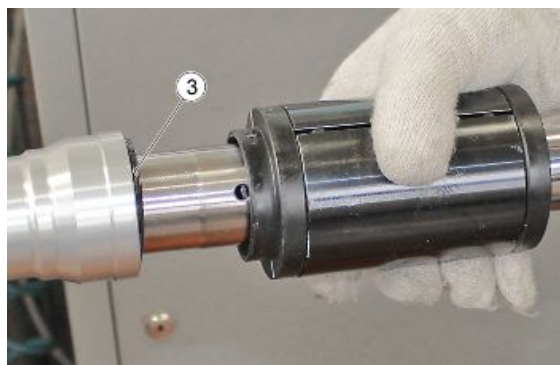

- Position the seeger ring (2) inside the sleeve.

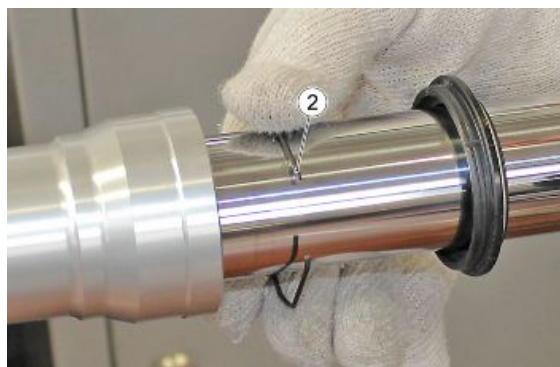

- Insert the dust guard (1) into its housing correctly.



- Place the fork stem vertically on a work surface.
- Fill the stem with the quantity of oil indicated in the "Refilling oil" section.



- Insert the buffer (7).

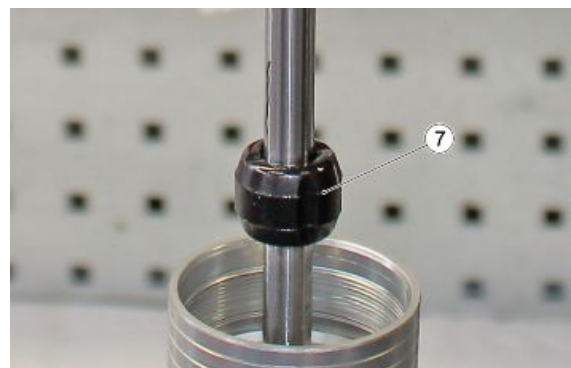

- Insert the special nut (8) and tighten it as far as it will go.



- Insert the cap (9) and tighten it as far as it will go.

CAUTION

CHECK THE O-RING PRESENT ON THE FILLING CAP AND REPLACE IF DAMAGED.



- Ensure that the cap cannot rotate, and then tighten the nut.



- Tighten the cap on the sleeve, applying the pre-defined torque.



V100 Mandello S

NOTE

THE FOLLOWING OPERATIONS ARE FOR OHLINS FORKS WITH ELECTRONIC ADJUSTMENTS.

- Install the following components on the wheel holder stanchion (1) in the order given: dust gaiter (3), retainer ring (4) and oil seal (5).

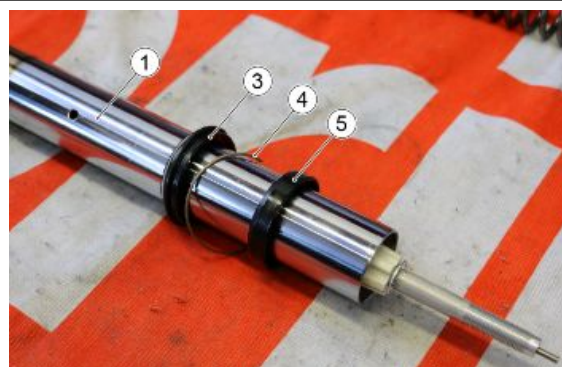

- Fix the sleeve in a vice, taking care not to damage the sleeve.
- Insert the stanchion (1) into the sleeve (2).



- Position the two halves of the special tool on the shaft (1) behind shaft seal (5), together with the respective buffer.
- Grip the special tool and push the shaft seal (5) into its housing on the sleeve (2).
- Remove the tool.



Specific tooling

AP8140189 Tool for fitting oil seal for 43 mm (1.69 in) diameter hole

AP8140146 Weight

- Insert the retaining ring (4) into its housing on the sleeve (2).

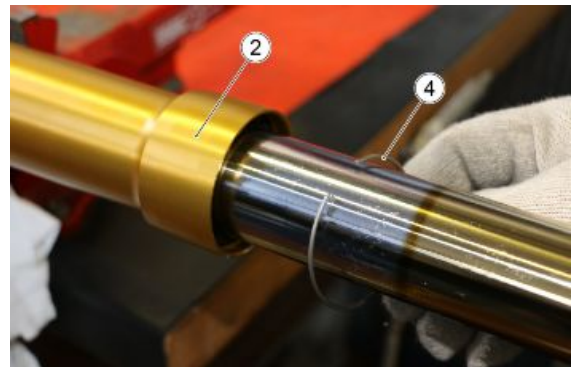

- Position the two halves of the special tool on the shaft behind anti-dust seal (3), together with the respective buffer.
- Grip the special tool and push the anti-dust seal (3) into its housing on the sleeve (2).
- Grasp the shaft and move it slowly, in alternating directions a few times.



CAUTION

THE SHAFT MUST SLIDE FREELY WITHIN THE SLEEVE, WITHOUT OBSTRUCTIONS.

Specific tooling

AP8140189 Tool for fitting oil seal for 43 mm
(1.69 in) diameter hole

AP8140146 Weight

Filling oil

V100 Mandello

NOTE

THE FOLLOWING OPERATIONS REFER TO THE KAYABA FORKS WITH MECHANICAL ADJUSTMENTS.

RIGHT-HAND STANCHION FILLING.

- Place the fork stanchion in a vice and lock it in a vertical position.
- Fill the stanchion with the specified oil quantity.



WARNING

OPERATE THE PLUNGER MULTIPLE TIMES UNTIL AIR BUBBLES MAY BE SEEN ON THE SURFACE OF THE OIL.



THE FORK MUST BE PERFECTLY UPRIGHT IN ORDER TO MEASURE THE CORRECT OIL LEVEL.

Characteristic

Quantity of oil for RH STEM

503 cc (30.70 cu in)

- Check the oil level from the rim of the sleeve.

Characteristic

Oil level (from sleeve rim, without the spring and with the pump all the way lowered)

97 mm (3.82 in)

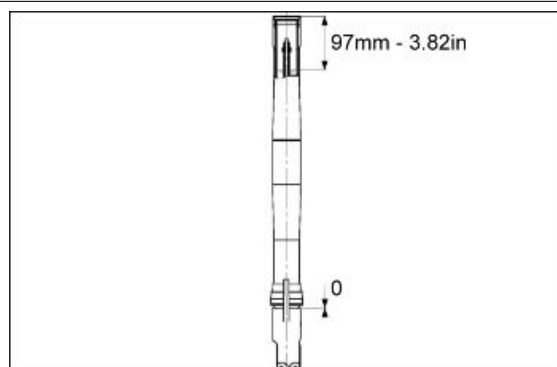

LEFT-HAND STANCHION FILLING.

- Place the fork stanchion in a vice and lock it in a vertical position.
- Fill the stanchion with the specified oil quantity.

WARNING

OPERATE THE PLUNGER MULTIPLE TIMES UNTIL AIR BUBBLES MAY BE SEEN ON THE SURFACE OF THE OIL.



THE FORK MUST BE PERFECTLY UPRIGHT IN ORDER TO MEASURE THE CORRECT OIL LEVEL.

Characteristic**Quantity of oil for LH stem**

378 cc (23.01 cu in)



- Check the oil level from the rim of the sleeve.

Characteristic**Oil level (from sleeve rim, without the spring and with the pump all the way lowered)**

95 mm (3.74 in)

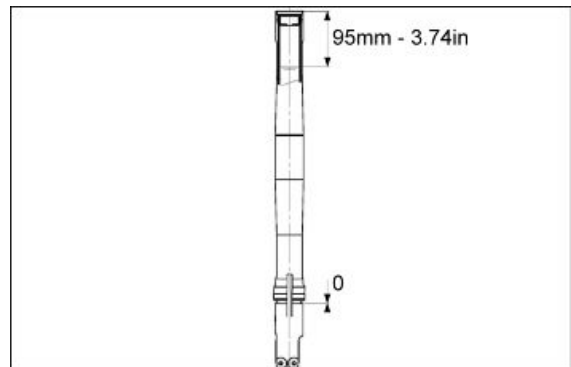
**V100 Mandello S****NOTE**

THE FOLLOWING OPERATIONS ARE FOR OHLINS FORKS WITH ELECTRONIC ADJUSTMENTS.

- Place the sleeve upright in a vice fitted with protection shoes.
- Compress the sleeve in the stanchion. Place a support under the stanchion in order to leave it compressed.
- Pour part of the fork oil into the sleeve.
- Wait a few minutes until the oil fills all the ducts.
- Pour the remaining oil.
- Pump out oil a few times.
- Measure the air gap between the oil level and the rim.

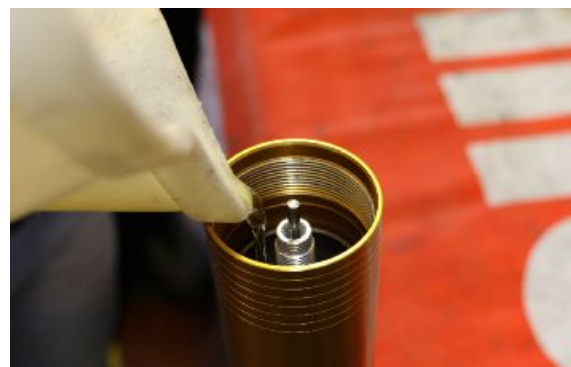



THE SLEEVE MUST BE PERFECTLY UPRIGHT IN ORDER TO MEASURE THE CORRECT OIL LEVEL. THE OIL LEVEL MUST BE THE SAME IN BOTH STANCHIONS.

Specific tooling

AP8140149 Guard for assembly operations

Oil level: 160 mm (6.30 in) (from the edge of the sleeve, without spring or pre-fill pipe).

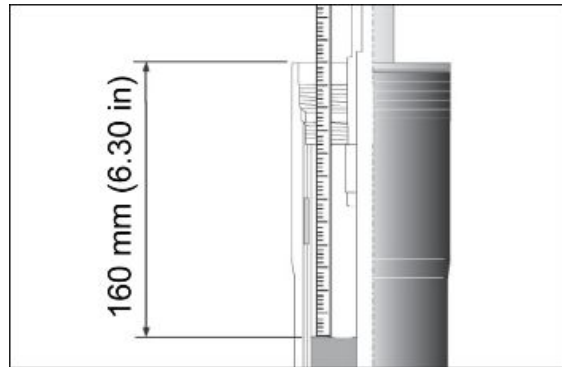

THE SLEEVE MUST BE PERFECTLY UPRIGHT IN ORDER TO MEASURE THE CORRECT OIL LEVEL. THE OIL LEVEL MUST BE THE SAME IN BOTH STANCHIONS.

Characteristic

Fork oil

460 ± 4 cc (28.07 ± 0.24 cu in)

- Insert the pre-load tube in the stanchion making sure that it is aligned correctly.



- Insert the spring.

CAUTION

PROCEED WITH CAUTION WHEN INSERTING THE SPRING AND ENSURE THAT THE PART WHERE THE SPIRAL IS MORE COMPRESSED IS FACING DOWNWARDS.



- Position the ring nut on the preload spring and keeping it compressed, screw the lock nut on the pumping element



- Tighten the nut as much as possible.
- Insert the cover and tighten until it stops.



- Using the special Ohlins tool, tighten the cap to the prescribed torque.



Upper steering yoke

Removal

- Unscrew the four fixing screws (1) and remove the U-bolt (2) of the handlebar.

During refitting, first tighten the front fixing screws and then the rear, all to the prescribed torque.

Locking torques (N*m)

Handlebar fixing screw 25 Nm (14.44 lbf ft)



- Place the handlebar on the tank. To avoid damage to the bodywork, place a protective cloth on the tank before placing the handlebar.



- Loosen the screw (3) of the steering plate, on both sides.

During refitting, tighten the screws to the prescribed torque.

Locking torques (N*m)

Upper steering plate screw 25 ± 2.5 Nm (18.44 ± 1.84 lbf ft)



- Remove the plug (4) of the steering plate.

During refitting, tighten the plug to the prescribed torque.

Locking torques (N*m)

Upper steering plate plug 100 Nm (73,76 lbf ft)



- Remove the steering plate from the vehicle.

NOTE

For the "MANDELLO S" version, before removing the upper steering plate, it is necessary to disconnect the wiring harnesses from the forks.



Steering bottom yoke

Removing

- To remove the lower steering plate, install a workshop stand to the rear wheel and place a pantograph jack under the engine to lift the front wheel off the ground. Check the stability of the vehicle.
- First remove the upper steering plate and both stanchions of the front fork.



To avoid damaging the vehicle, place a protection between the jack and the sump oil.

NOTE

It is possible to remove the lower steering plate also with the fork stanchions fitted.

- Retrieve the safety washer (1).

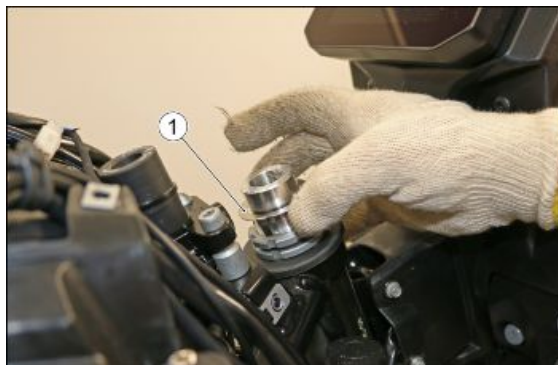

- Remove the four fixing screws (2) and remove the plastic (3) from the lower steering plate.

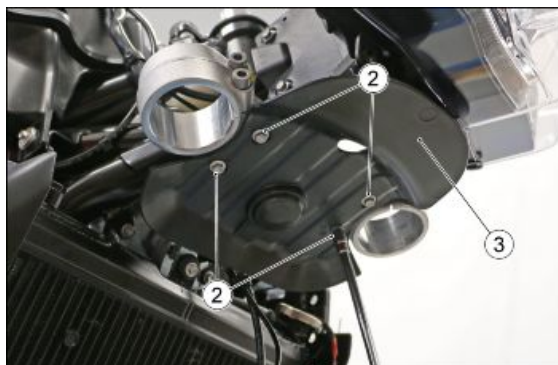

- Using the specific tool, unscrew the counter-lock ring (4).

Specific tooling**020966Y Steering adjustment socket**

Remove the counter-lock ring (4) and the rubber spacer (5).

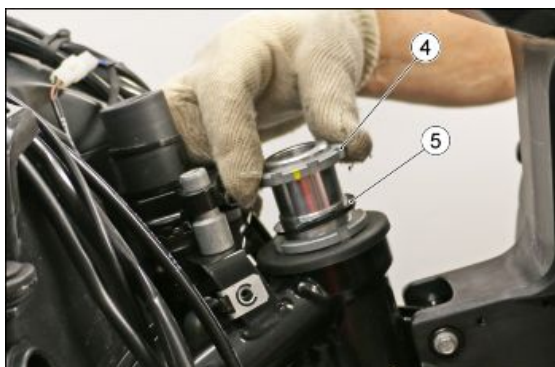

- Using the specific tool, unscrew and remove the ring nut (6) of the steering headstock.

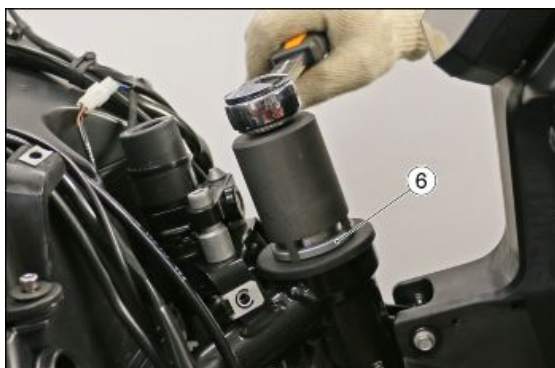
Specific tooling**020966Y Steering adjustment socket**

- Retrieve the dust seal ring (7).

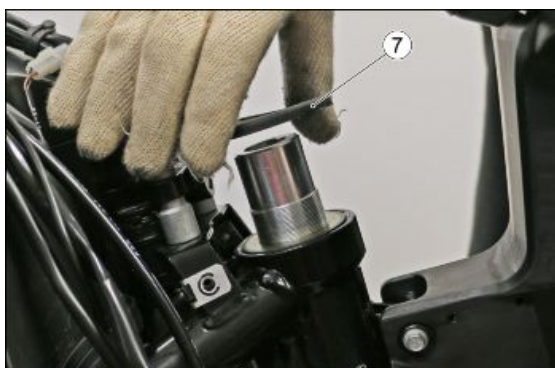

- Remove the shim washer (8) of the upper bearing.

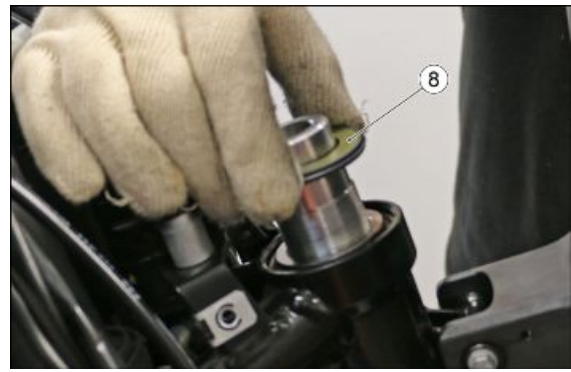

- Remove the internal ring (9) of the upper bearing.



- Remove the balls of the upper bearing (10).



Remove the lower steering plate from the vehicle.

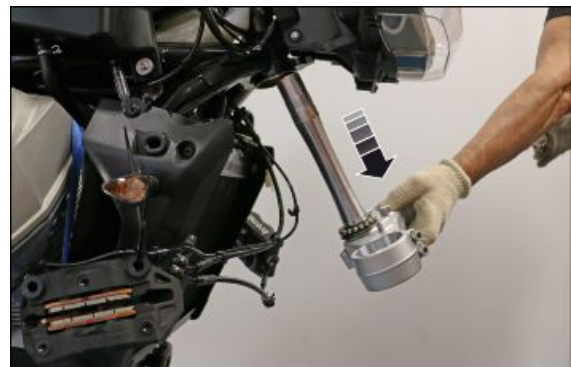

- Remove the balls of the lower bearing (11) from the steering plate.

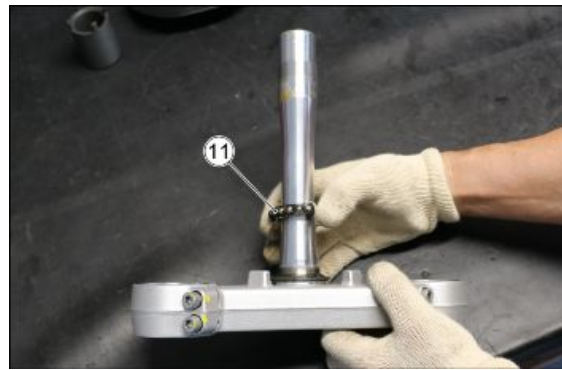

Steering bearing

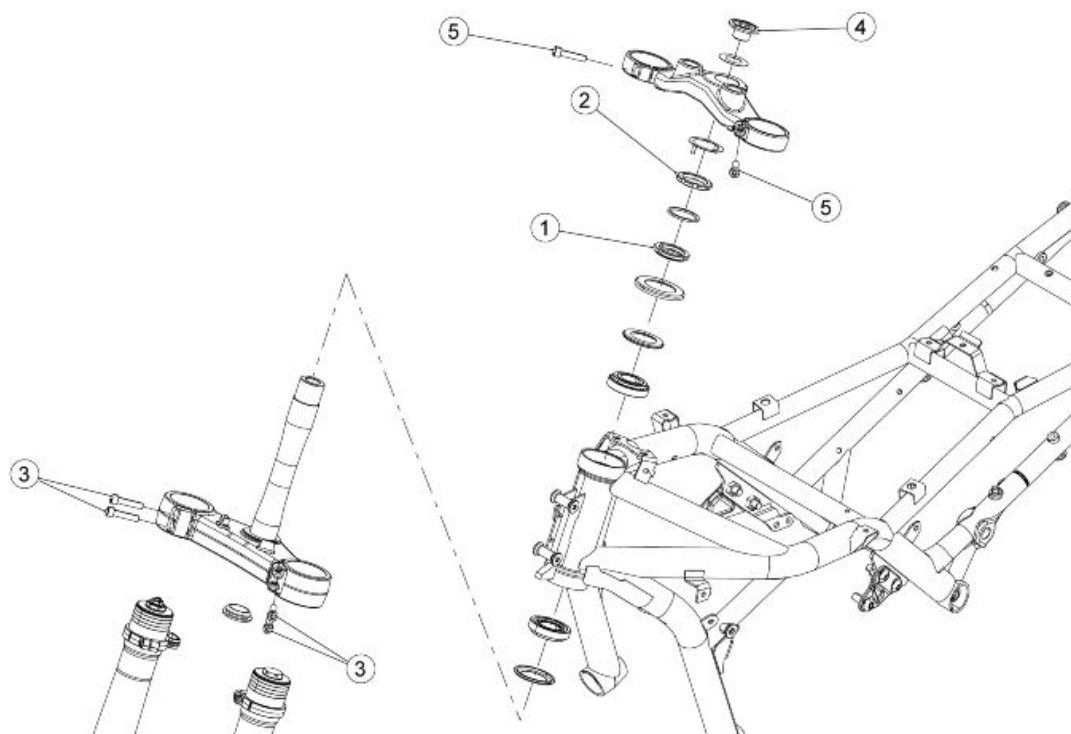

STEERING

Pos.	Description	Type	Quantity	Torque	Notes
1	Ring nut fastening the bottom yoke/steering pin assembly to the headstock	-	1	-	First tightening torque 60 Nm (44.25 lbf ft) - Second tightening torque 30 Nm +/- 5 Nm (22.13 +/- 3.69 lbf ft)
2	Counter-lock ring fastening the bottom yoke/steering pin assembly to the headstock	-	1	-	Manual
3	Screw fastening the fork stanchions to the lower steering yoke	M8	4	25 Nm (18.44 lbf ft)	-
4	Top steering yoke fastener bush	-	1	100 Nm (73.76 lbf ft)	-
5	Screw fastening the fork stanchions to the upper steering yoke	M8	2	25 Nm (18.44 lbf ft)	-

Adjusting play

To adjust the steering play, follow the procedure described below:

- Place the vehicle so that the front wheel is off the ground.
- Carry out a handlebar rotation test, using a dynamometer at the hand grip external end.
- The handlebar resistance to rotation must be of 250 +/- 100 g (0.55 +/- 0.22 lb) in both directions.
- Adjust if clearance is detected.

NOTE

THE STEERING COLUMN RESISTANCE TO ROTATION MUST BE PERFORMED IN THE TWO OPPOSITE ROTATION DIRECTIONS.

- Remove the handlebars and upper steering triple clamp.

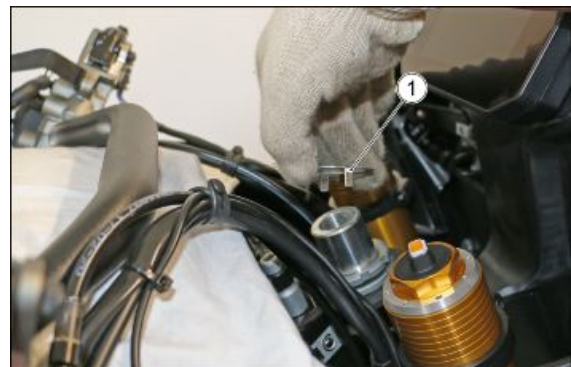

Then proceed as described:

- Remove the steering safety plate (1).

- Remove the upper steering ring nut (2) using the special tool.



Specific tooling

020966Y Steering adjustment socket

- Remove the rubber shim (3).



- Unscrew the lower ring nut (4) using the special tool.

Repeat the steering assembly tightening procedure in the correct manner as described:

- Pre-tighten the ring nut (4) to 60 Nm (44.25 lbf ft).
- Turn the handlebar to the left and right as far as it will go to seat the bearings.
- Unscrew the ring nut and tighten it again to 30 +/- 5 Nm (22.13 +/- 3.69 lbf ft).



Specific tooling

020966Y Steering adjustment socket

- Insert the rubber shim (2) and then manually screw the counter-lock ring (3) until it is in contact with the shim itself. Make sure that the slots of the counter-lock ring (3) are aligned with those of the ring nut (4).
- Fit the safety washer (1).
- Check that the handlebar resistance to rotation is 250 +/- 100 g (0.55 +/- 0.22 lb) in both directions.

Disassembling

Install a workshop stand to the rear wheel and place a pantograph jack under the engine in order to lift the front wheel from the ground. Check the stability of the vehicle.



To avoid damaging the vehicle, place a protection between the jack and the sump oil.



- Remove the lower steering plate.
- Using a generic bearing extractor, remove the outside seat of the upper steering bearing.



- Using a generic bearing extractor, remove the outside seat of the lower steering bearing.



- Remove the inner ring (1), together with the balls, of the lower bearing from the steering headstock pipe.
- Using a workshop heating gun, heat the internal seat (2) of the bearing and then remove it from steering headstock pipe.
- Retrieve the dust seal ring (3).

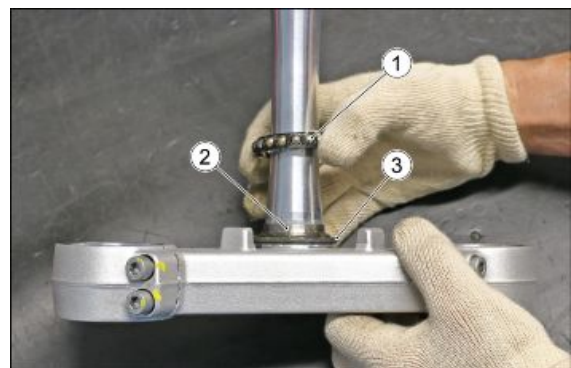

Assembling

- Working on the bench, pre-fit on the steering headstock pipe the dust seal ring (3), the internal seat (2) and the inner ring (3) with the balls of the lower steering bearing.



Lubricate the inserted seat with grease for bearings.

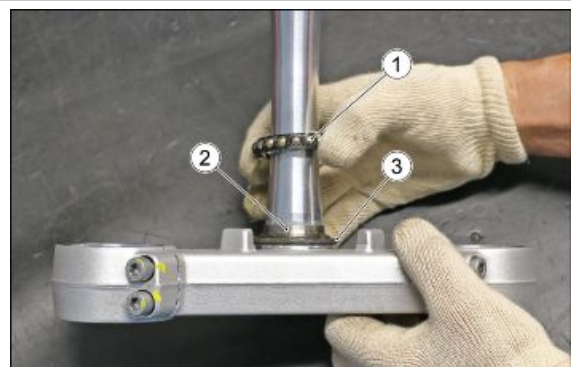

- Using the specific tool, completely insert the external seat of the upper bearing.



Lubricate the inserted seat with grease for bearings.

Specific tooling

020376Y Adaptor handle

020360Y 52 x 55 mm adaptor



- Using the specific tool, completely insert the external seat of the lower bearing.



Lubricate the inserted seat with grease for bearings.

Specific tooling

020376Y Adaptor handle

020360Y 52 x 55 mm adaptor



- Insert the lower steering plate in the headstock, together with the bearing.



- Use a bearing grease to lubricate the upper steering bearing inner ring (4), together with the balls.
- Support the lower steering plate and insert the inner ring (4) inside the steering headstock.



- Lubricate the internal seat (5) of the upper steering bearing with bearing grease.
- Support the lower steering plate and insert the internal seat (5) inside the steering headstock.



- Support the lower steering plate and insert the dust seal ring (6) on the steering headstock.



- Support the lower steering plate and insert the rubber dust seal ring (7) on the steering headstock.

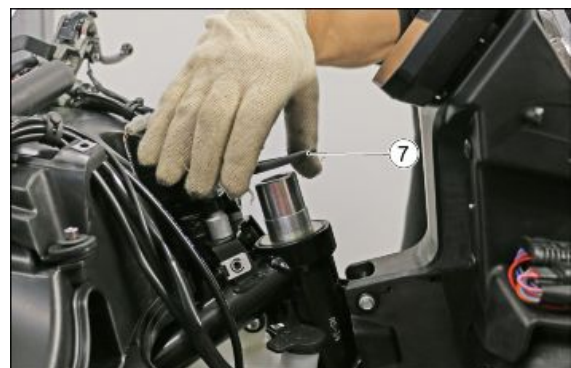

- Support the lower steering plate and insert the ring nut (8) on the steering headstock and bring it to the end with the dust seal ring (7).



- Using the specific tool, pre-tighten the ring nut (8) to the torque of 60 Nm (44.25 lbf ft).
- Turn the handlebar to the right and left until the end of the stroke, to allow the bearings to settle.
- Unscrew the ring nut (8) and tighten it to a torque of 30 ± 5 Nm (22.23 ± 3.68 lbf ft).
- Turn the handlebar to the right and left several times through its full travel and make sure that the rotation is smooth and free of jams.

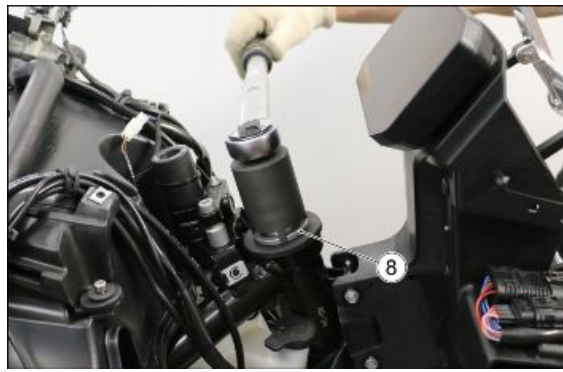

Specific tooling

020966Y Steering adjustment socket

- Insert the rubber shim (9) on the steering headstock.
- Screw the counter-lock ring (10) until it is in contact with the shim (9).

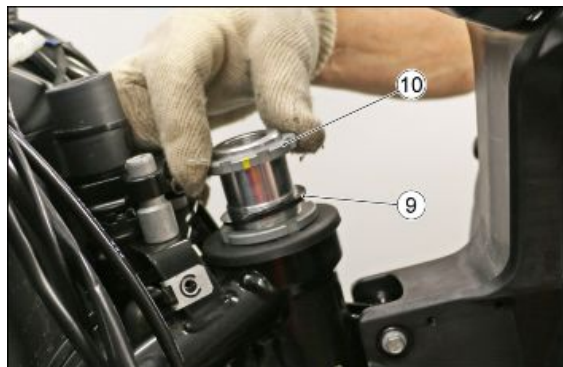

- Align the grooves of the counter-lock ring (10) with those of the ring nut (8).

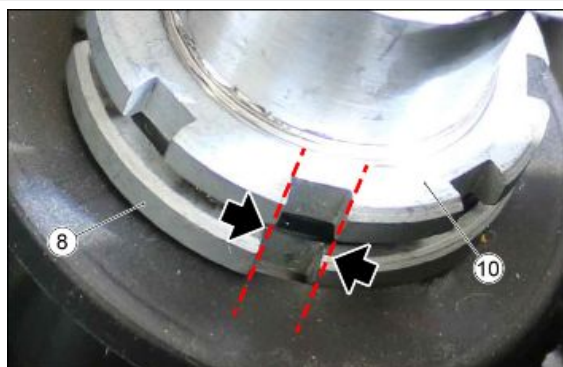

- Insert the safety plate (11) on the ring nuts of the steering headstock.
- Refit the previously removed components.

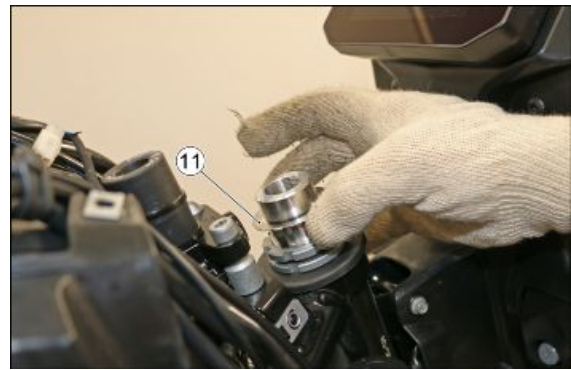

Rear

Shock absorbers

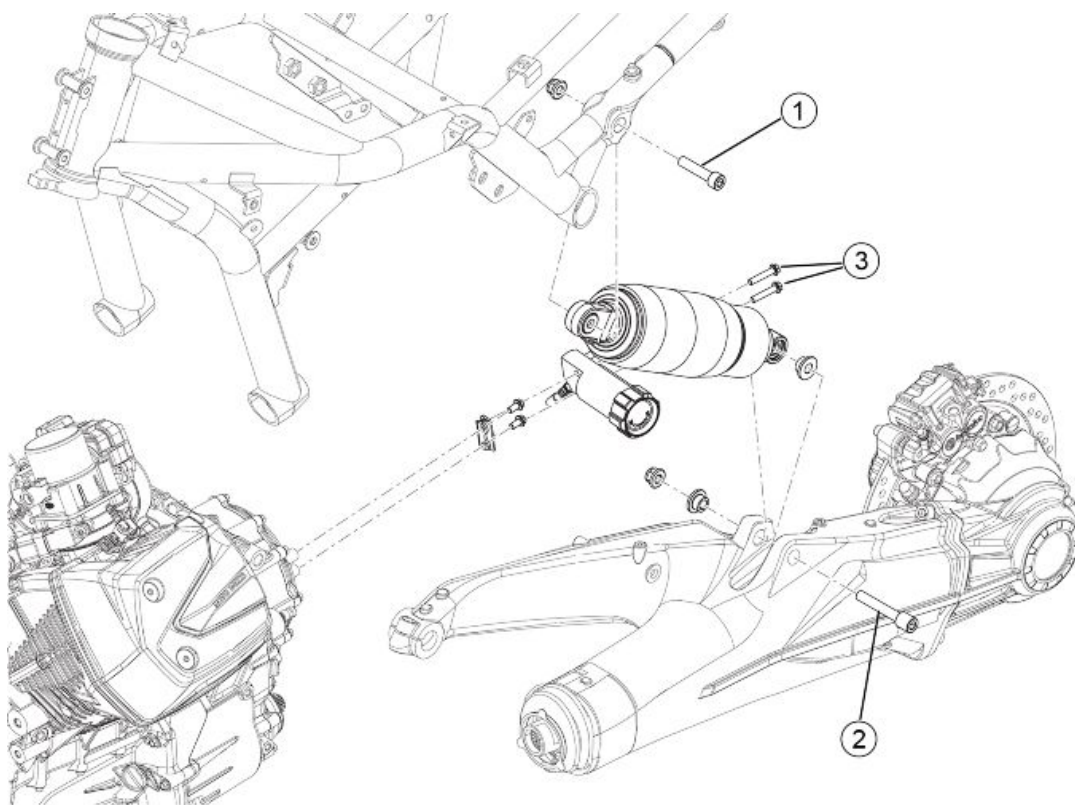

REAR SHOCK ABSORBER

Pos.	Description	Type	Quantity	Torque	Notes
1	Upper shock absorber fixing screw	M10	1	50 ± 7.5 Nm (36.87 ± 5.53 lb ft)	-
2	Lower shock absorber clamping screw	M10	1	50 ± 7.5 Nm (36.87 ± 5.53 lb ft)	-
3	Fixing screw for preload tank to bracket	M6	2	10 ± 2 Nm (7.37 ± 1.47 lb ft)	-

Removing

Properly support the vehicle by means of a pantograph.



Unscrew the fixing screws of the preload tank to the support bracket.



Remove the preload tank.



Position the preload tank so that it is not in the way of subsequent operations; protect the support area properly.



While holding the rear nut (1), unscrew the screw (2).

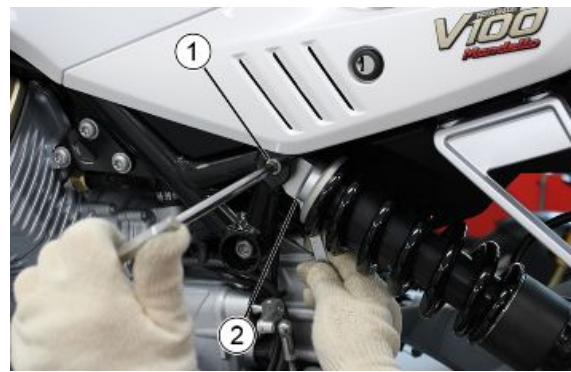

Remove the screw (2).



Retrieve the nut (1).



While holding the rear nut (3), unscrew the screw (4).

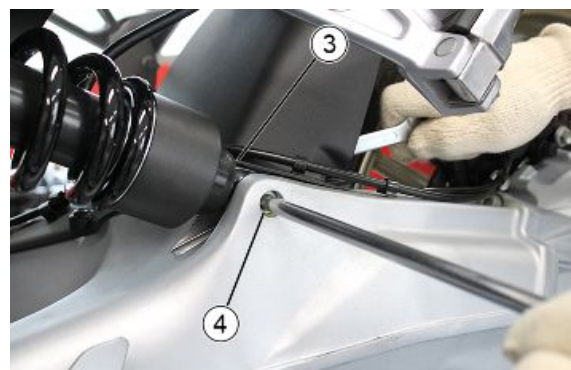

Remove the screw (4).



Retrieve the nut (3).

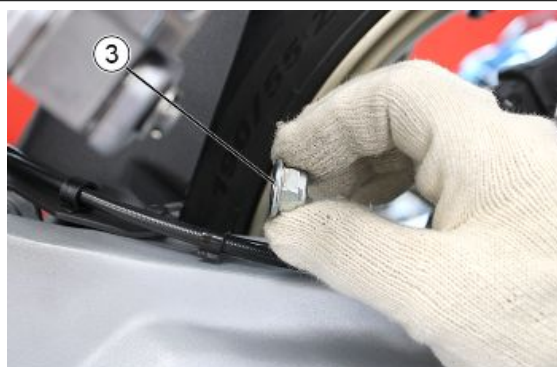

Remove the damper complete with the preload tank.



FOR "MANDELLO S" VERSION

Before removing the damper with the preload tank as described above, the electrical connectors of the wiring harness from the electronic suspension ECU must be disconnected.



Proceed as follows:

- remove the passenger and driver's seat;
- remove the battery cover;
- disconnect and remove the battery;
- disconnect and remove the engine ECU;
- remove the engine ECU bracket;

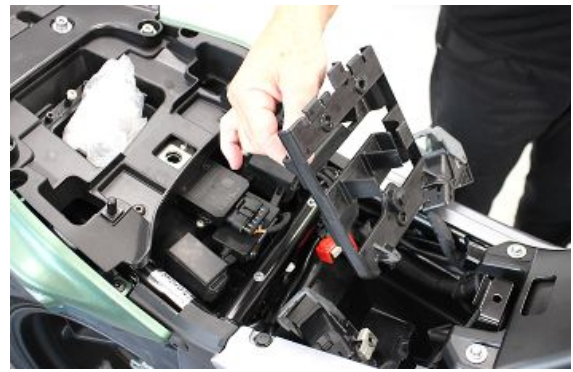

Remove the right side panel and remove the inner side fairing underneath.



Disconnect the first wire harness connector from the suspension ECU.



Remove the rubber clamp.

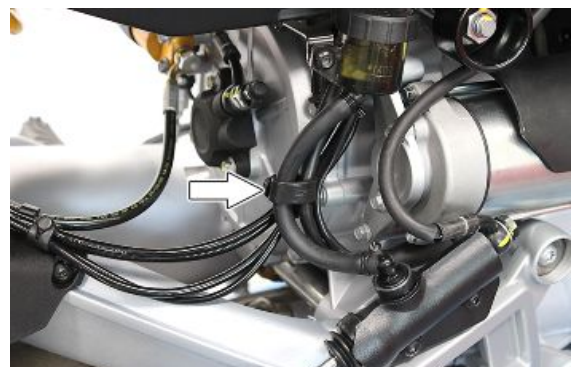

Remove the rear brake oil tank by unscrewing the fixing screw.



Remove the fixing rubber calmp from the rear brake hose.

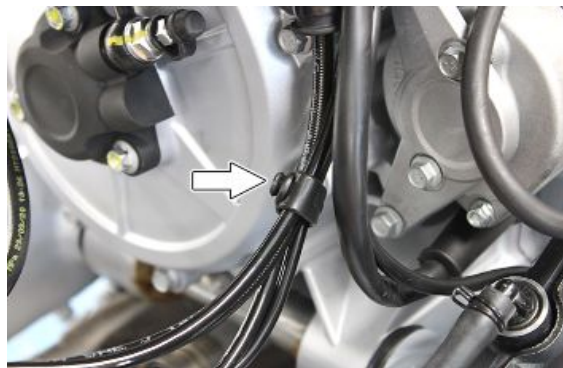

Remove the fixing metal calmp from the rear brake hose.



Unscrew and remove the saddle screw so that it can be detached from the chassis.



Cut the fixing calmp from the electrical wiring harnesses.



Remove the second ECU suspension wire harness connector from the saddle.



Disconnect the second connector.



Installing

Position the shock absorber complete with preload tank in its seat.



Insert the rear nut (3).



Holding the rear nut (3), tighten the screw (4) to the prescribed torque.



Insert the rear nut (1).



Holding the rear nut (1), tighten the screw (2) to the prescribed torque.



Position the preload tank on the support bracket and tighten the fixing screws to the prescribed torque.

NOTE

FOR THE "MANDELLO S" VERSION, PROCEED WITH THE INSTALLATION OF THE ELECTRICAL WIRING BY PERFORMING THE OPERATIONS IN REVERSE ORDER FROM THE REMOVAL.

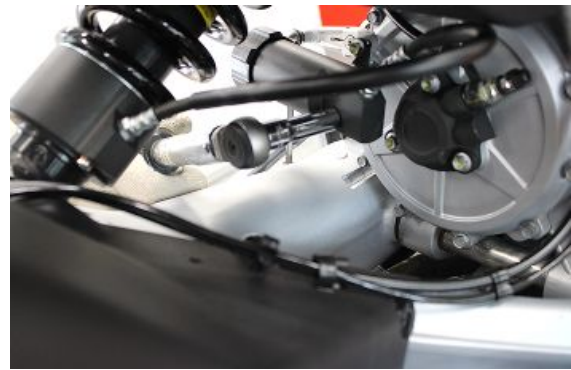

INDEX OF TOPICS

CHASSIS

CHAS



FOR MAINTENANCE/REPAIR WORK AND WHERE THERE IS A NEED TO LIFT THE VEHICLE WHEELS OFF THE GROUND, INSTALL A WORKSHOP STAND AT THE REAR WHEEL AND PLACE A PANTOGRAPH JACK UNDER THE OIL SUMP. PLACE A GUARD BETWEEN THE JACK AND THE OIL SUMP TO PREVENT DAMAGE TO THE OIL SUMP. FINALLY, MAKE SURE THAT THE VEHICLE IS STABLE BEFORE CARRYING OUT ANY OPERATION.



Wheels

REPLACEMENT PROCEDURE OF THE TPMS SENSOR - VALVE

Remove the relevant wheel from the vehicle.

NOTE

The following procedure applies to the rear tyre, but is also applicable to the front tyre.

Remove the tyre using a tyre changer.

CAUTION

The bead breaking of the tyre must take place at a distance of at least 90° from the inflation valve.



CAUTION

The positioning of the levers for the removal of the tyre must be at a distance of at least 10 cm (3.93 in) from the inflation valve.



Completely remove the tyre from the rim.



Remove the screw (1) that fastens the TPMS sensor to the valve.



Remove the retaining nut (2) and slide off the valve (3) from inside the rim.



Fit the new valve kit for TPMS (3) - code **2D000689** for tubeless wheels.

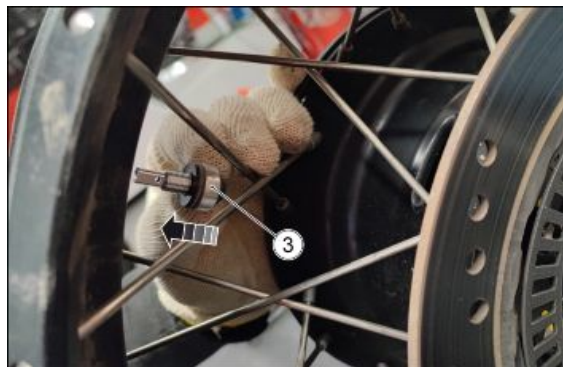

Insert and tighten the valve retaining nut (2) to the prescribed torque.

Locking torques (N*m)

Valve retaining nut 4.7 ± 0.25 Nm (3.47 ± 0.18 lb ft)

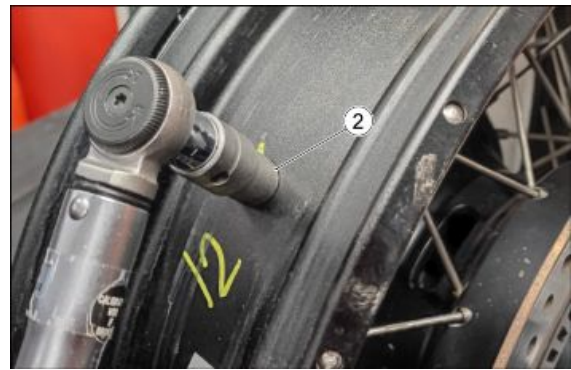

Install and tighten to the prescribed torque the screw (1) that fastens the TPMS sensor to the valve.

Locking torques (N*m)

Sensor retaining screw 1.3 ± 0.05 Nm (0.96 ± 0.037 lb ft)

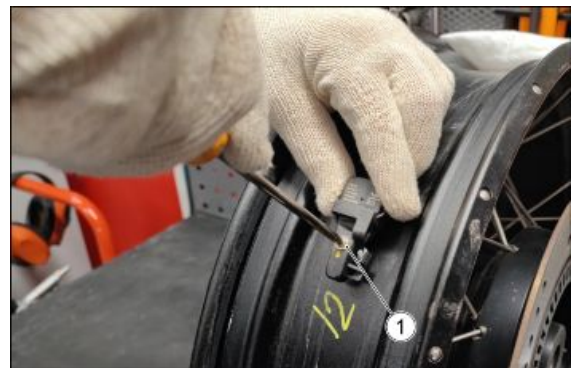

Reassemble the tyre using a tyre changer.
Lubricate the edges of the tyre with grease to aid insertion into the seat.



Once the tire has been inserted in its seat, inflate the tyre to the following pressure:

Rear tyre: 2.8 bar (280 KPa) (40.61 PSI).

Front tyre: 2.5 bar (250 KPa) (36.26 PSI).



Once the wheels have been reassembled on the vehicle, the following operations are required using the P.A.D.S. diagnostic tool.

- Connect the P.A.D. S. to the vehicle and find the model "V100 Mandello";
- select the section "TYRE PRESSURE MONITORING - TPMS"

- select the "SELF-DIAGNOSIS" function



- Select the "ADJUSTMENTS" tab



- select "vehicle configuration" and press "OK"



- select "front wheel TPMS learning" and press "OK"



- When required by P.A.D.S., deflate the front tyre, until the learning is complete.

WARNING

THE DEFLATION / LEARNING OPERATION MUST BE PERFORMED WITHIN A MAXIMUM 90 SECONDS.

CAUTION

TO BE ABLE TO PERFORM THE CALIBRATION, THE SENSOR MUST DETECT A DECREASE IN TYRE INFLATION PRESSURE.

ONCE THE LEARNING IS COMPLETE, THE TYRE PRESSURE MUST BE BROUGHT BACK TO THE NOMINAL VALUE. EVEN IF THE INITIAL PRESSURE IS ABOVE THE VALUE, IT WILL STILL BE REQUIRED TO ADJUST THE INFLATION PRESSURE TO THE CORRECT VALUE.



- Repeat the learning operations for the rear wheel also, selecting "Rear wheel TPMS learning".
- After both learning procedures have been performed, wait a few minutes for the sensors to align with the vehicle ECU. Any errors present will pass to the "STORED" status and can be cancelled.
- The current tyre pressure and temperature data will be displayed by selecting the "PARAMETERS AND STATUS" tab.

CAUTION

If the pressure is 5.10 bar and temperature is 205 °C, it means that the sensor is not calibrated. If a condition of this type occurs, it is necessary to carry out the TPMS learning procedure again.

INFO ECU	PARAMETRI E STATI	REGOLAZIONI	ATTIVAZIONI	CODICI ERRORE	REPORT
f	Pressione ruota anteriore	5.10	bar		
f	Temperatura ruota anteriore	205	°C		
f	Pressione ruota posteriore	5.10	bar		
f	Temperatura ruota posteriore	205	°C		

Front wheel

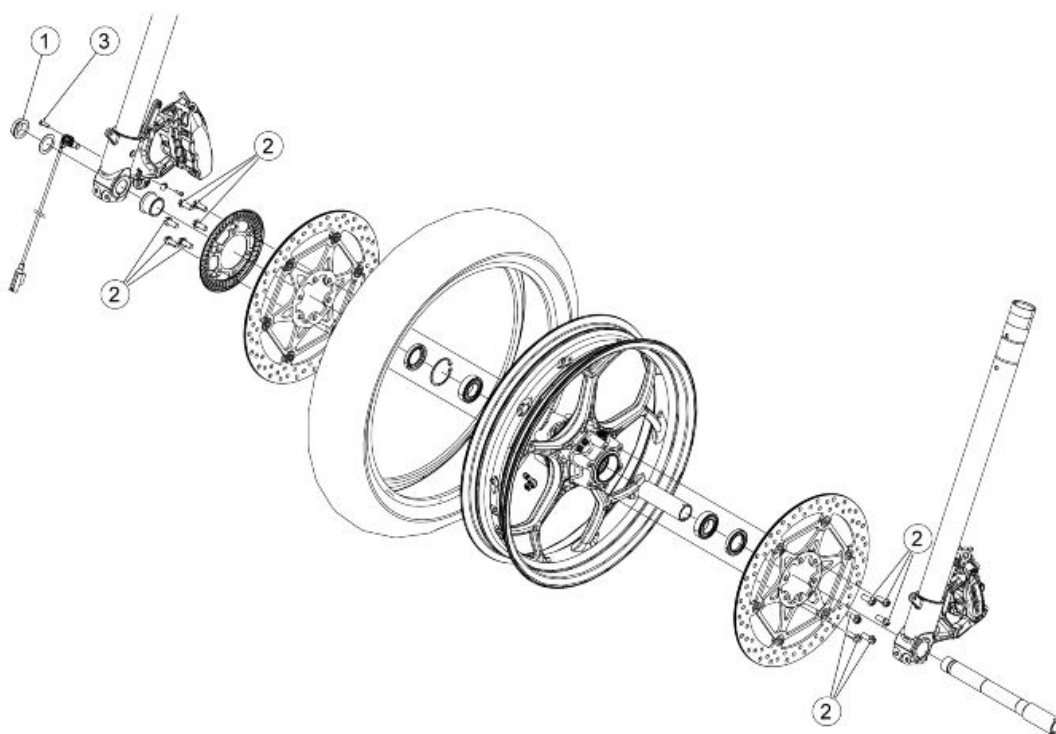

FRONT WHEEL

Pos.	Description	Type	Quantity	Torque	Notes
1	Nut fastening the front wheel axle	M25x1.5	1	80 Nm (59.01 lbf ft)	
2	Brake disc fixing screw	M6	6 + 6	30 Nm (22.13 lbf ft)	Loctite 243
3	ABS sensor fixing screw	M5	1	6 Nm (4.46 lbf ft)	-

Removal

REMOVAL

To remove the front wheel, install a workshop stand to the rear wheel and place a pantograph jack under the engine to lift the front wheel off the ground. Check the stability of the vehicle.



To avoid damaging the vehicle, place a protection between the jack and the sump oil.



- First remove the front mudguard.
- Release the ABS sensor cable from the 4 retainers of the brake pipe.



- Remove the two fixing screws (1) and remove the brake calliper (2) from the vehicle; repeat for the opposite side.



- Remove the plastic clamp (3).



- Remove the fixing screw and remove the ABS sensor (4) from its housing on the right hand calliper mounting bracket.



- Unscrew the nut of the wheel axle (5) and recover the relative washer (6).



- Loosen the screws of the right foot.



- Loosen the screws of the left foot.



- Slide off the wheel axle from the front suspension.



- Remove the front wheel from the vehicle.



- Remove the spacer (7) on the right side of the wheel.



REMOVAL OF EXTERNAL WHEEL COMPONENTS

After removing the front wheel, operating from the right side:

- Remove the six fixing screws (8) and remove the tone wheel (9) from the wheel.

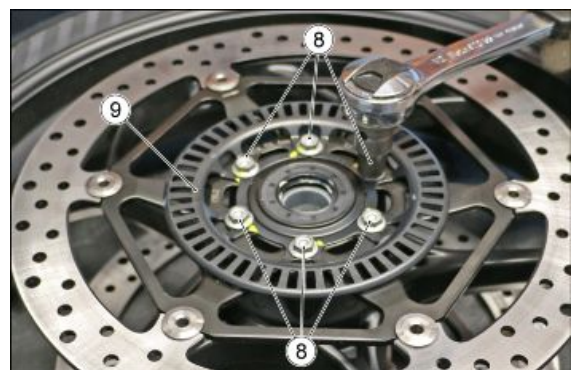

- Remove the right-hand brake disc (10).



- Working on the opposite side, unscrew the six fixing screws (11) and remove the left-hand brake disc (12).



REMOVAL OF INTERNAL WHEEL COMPONENTS

- Remove the dust guard (13).



Remove the bearing using a generic extractor, proceeding as follows:

- Insert the collar (A) into the bearing, and screw the pin (B) into the bearing until the collar is securely fastened to the bearing.
- Insert the thrust bushing (C) and nut (D) onto the collar (A).
- Hold the collar (A) while tightening the nut (D) to push the bearing out of its seat.

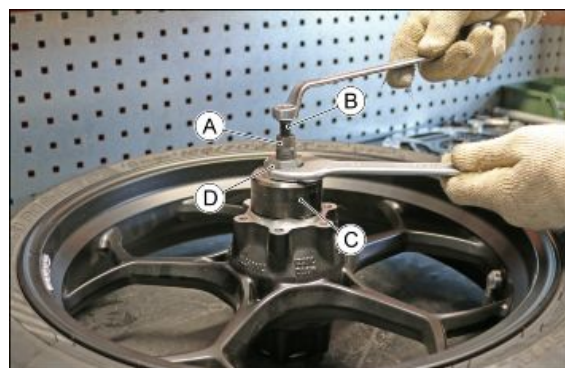

NOTE

REPEAT THE OPERATION DESCRIBED ABOVE, TO REMOVE THE BEARING ON THE OPPOSITE SIDE OF THE WHEEL.

- Once the first bearing has been removed, retrieve the inner spacer from the wheel hub before removing the second bearing.
-

Checking

FRONT WHEEL BEARINGS

Check the bearings installed on the wheel.



CHECK THE CONDITION OF ALL COMPONENTS AND OF THE COMPONENTS INDICATED AS FOLLOWS IN PARTICULAR.

CHECKING ROTATION

- Manually rotate the inner race of each bearing. The race must turn smoothly without impediment or noise.

If one or both bearings do not fall within the control parameters:

- Replace both wheel bearings.

CHECKING RADIAL AND AXIAL PLAY

- Check the radial and axial play.

Axial play: minimal axial play is permitted.

Radial: none.

If one or both bearings do not fall within the control parameters:

- Replace both wheel bearings.



**ALWAYS REPLACE BOTH BEARINGS.
ALWAYS REPLACE THE BEARINGS WITH COMPONENTS OF THE SAME TYPE.**

SEALS

- Check the condition of the seals; replace if damaged or excessively worn.



**ALWAYS REPLACE BOTH SEALS TOGETHER.
ALWAYS REPLACE THE SEALS WITH COMPONENTS OF THE SAME TYPE.**

WHEEL AXLE

- Use a dial gauge to measure the eccentricity of the wheel axle. Replace the wheel axle if the eccentricity measured exceeds the specified limit.

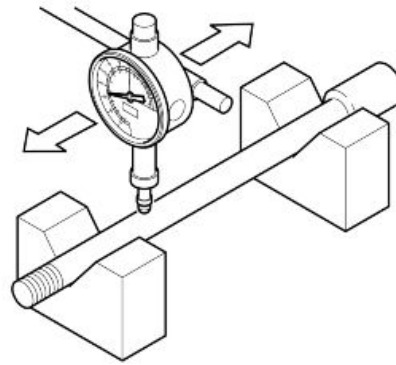
**Characteristic****Maximum eccentricity:**

0.25 mm (0.0098 in)

- Use a dial gauge to check that the radial (A) and axial (B) eccentricity of the wheel do not exceed the specified limits. Excessive eccentricity is usually caused by worn or damaged bearings. If eccentricity is not within the indicated limits after replacing the bearings, replace the wheel.

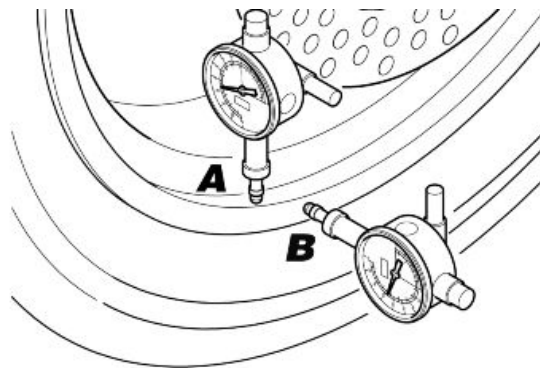
**Characteristic****Maximum radial and axial eccentricity:**

0.8 mm (0.031 in)

Installing**INSTALLATION OF INTERNAL WHEEL COMPONENTS**

- Insert the bearing into the wheel hub and bring it to the stop using the special equipment.

Specific tooling**020359Y 42 x 47 mm Adaptor****020376Y Adaptor handle**

- Insert the inner spacer the wheel hub, and repeat the insertion of the bearing on the opposite side.
- Insert the dust seal (13) and bring it flush with the wheel hub.
- Repeat the operation for the dust seal on the opposite side.



INSTALLATION OF EXTERNAL WHEEL COMPONENTS

- Install the left brake disc (12) on the rim.
- Gradually screw in the six attachment screws (11) following the sequence A-B-C-D-E-F and tighten them to the specified torque.

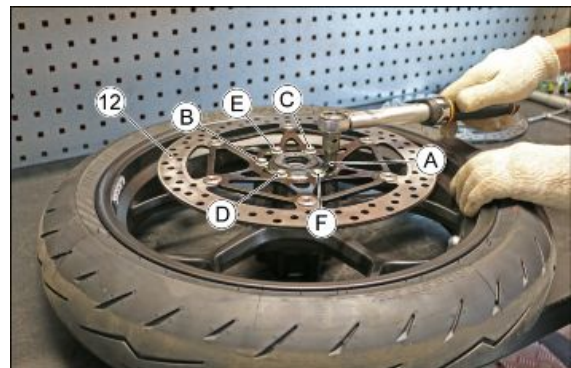

Locking torques (N*m)

Brake disc fixing screw 30 ± 4.5 Nm (22.13 ± 3.32 lb ft)

- Working on the opposite side, fit the brake disc right (10) and the tone wheel (9) on the rim.
- Gradually screw in the six attachment screws (8) following the sequence A-B-C-D-E-F and tighten them to the specified torque.

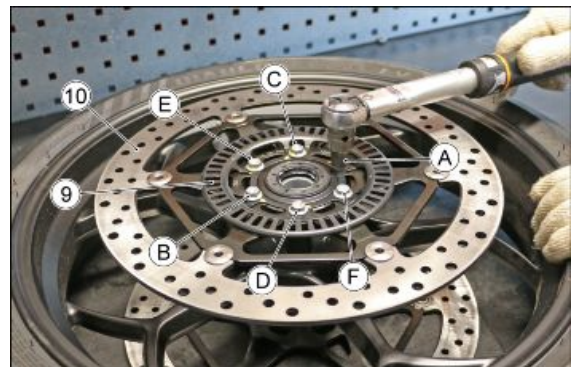

Locking torques (N*m)

Brake disc fixing screw 30 ± 4.5 Nm (22.13 ± 3.32 lb ft)

- Fit the spacer (7) on the right side of the wheel.



FRONT WHEEL INSTALLATION

- Install the front wheel on the vehicle and insert the wheel axle into the fork feet.



- Tighten the screws of the right foot to the prescribed torque.

Locking torques (N*m)

Calliper mounting bracket screw 10 Nm (7.38 lbf ft)



- Install the washer (6) and the nut (5) on the wheel axle.
- Tighten the nut (5) to the prescribed torque.

Locking torques (N*m)

Wheel axle nut 80 ± 12 Nm (59 ± 8.85 lbf ft)



- Tighten the screws of the left foot to the prescribed torque.

Locking torques (N*m)

Calliper mounting bracket screw 10 Nm (7.38 lbf ft)

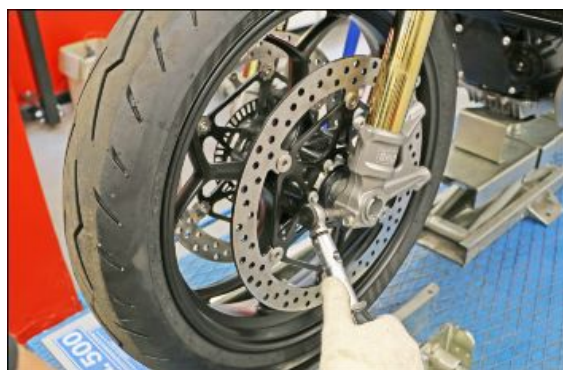

- Reinsert the ABS sensor (4) in its seat and tighten the fixing screw.



- Fit the brake calliper (2) on the brake disc and tighten the fixing screws (1) to the prescribed torque.
- Repeat for the brake calliper on the opposite side.



Locking torques (N*m)

Brake calliper fixing screw 50 ± 5 Nm (36.88 ± 3.69 lbf ft)

- Refit the plastic clamp (3) and reposition the ABS cable in the four retainers on the brake pipe.
- Perform several rotations to check that the wheel moves freely and smoothly.
- Refit the front mudguard.
- Remove the pantograph jack and the rear stand.



Rear wheel

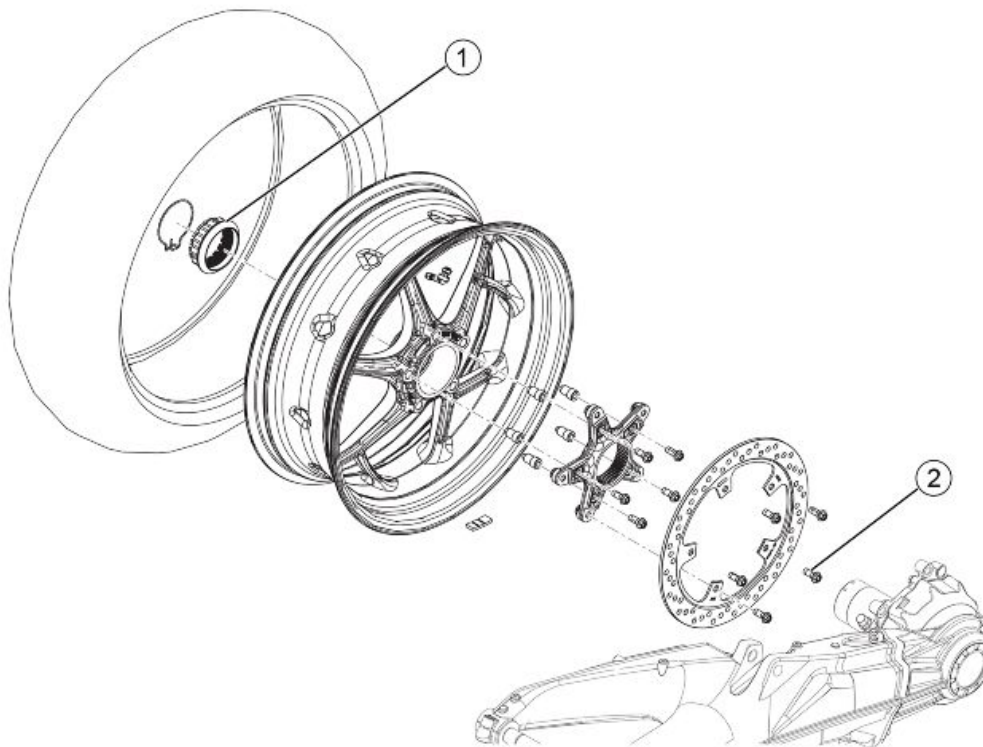

REAR WHEEL

Pos.	Description	Type	Quantity	Torque	Notes
1	Rear wheel nut	M60x2	1	260 ± 39 Nm (191.75 ± 28.76 lb ft)	-
2	Rear brake disc fixing screw	M8	5	30 ± 4.5 Nm (22.12 ± 3.32 lb ft)	Screws with pre-applied threadlocker

Rimozione

- Install a workshop stand to the rear wheel, so as to keep it raised off the ground.
- Remove the exhaust end first.



- Open the safety circlip (1).



- Remove the safety circlip (1) from the hole on the wheel hub and remove it from the vehicle.



- Unscrew the nut (2) from the hub.
During refitting, tighten the nut (2) to the prescribed torque.



- Remove the rear wheel from the vehicle.



During refitting, make sure to correctly insert the pins of the flange of the brake disc in the corresponding holes of the rim.



Checking

- Check the wheel for damage to the mating surfaces with the wheel hub and fixing nut. Also check that there are no signs of damage and/or for cracks along the spokes and the duct of the rim.

Swinging arm

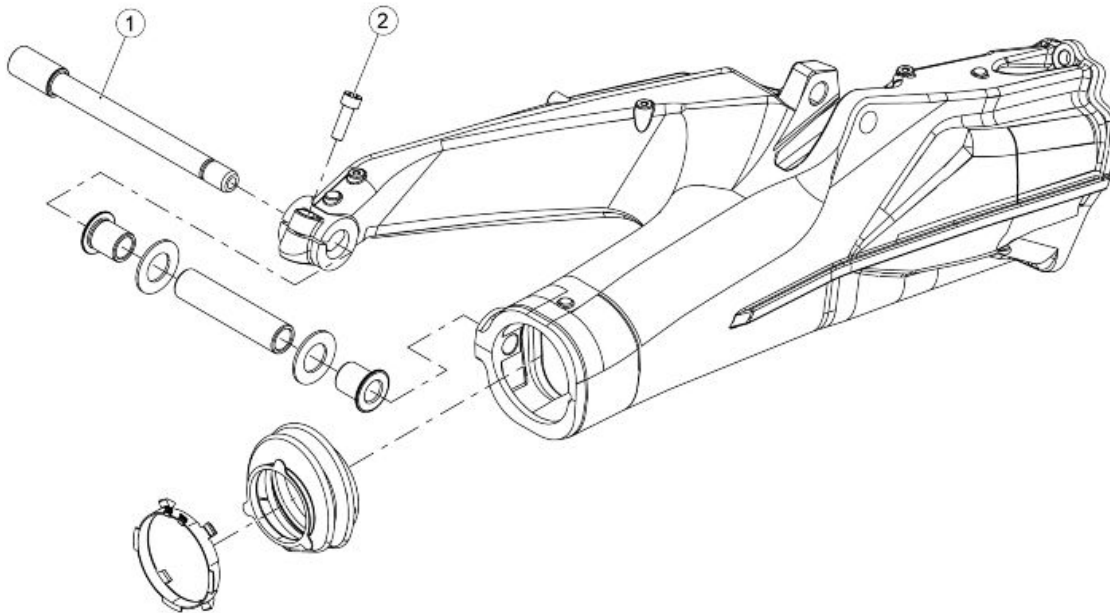

SWINGARM

Pos.	Description	Type	Quantity	Torque	Notes
1	Swingarm pin	M16 x 1.5	1	65 ± 9.5 Nm (47.94 ± 7.01 lb ft)	-
2	Swingarm pivot screw	M8	1	28 ± 4 Nm (20.65 ± 2.95 lbf ft)	-
-	Rear shock absorber lower fixing screw	M10	1	50 ± 7.5 Nm (36.88 ± 5.53 lb ft)	-

Removing

- First remove the bevel gear.
- Cut the plastic clamp (1) from the dust guard cap.



- Holding the nut (2), unscrew the lower fixing screw (3) of the rear shock absorber.

During refitting, tighten the fixing screw to the prescribed torque.

Locking torques (N*m)

Rear shock absorber lower fixing screw 50 ± 7.5 Nm (36.88 ± 5.53 lb ft)



- Remove the lower fixing screw (3) of the rear shock absorber.
- Disconnect the rear shock absorber from the swingarm.



- Remove the wiring harnesses and the rear brake hose from the cable gland, as indicated in the figure.



- Loosen the screw (4) of the swingarm pivot.

During refitting, tighten the screw of the swingarm pivot to the prescribed torque.

Locking torques (N*m)

Swingarm pivot screw 28 ± 4 Nm (20.65 ± 2.95 lbf ft)

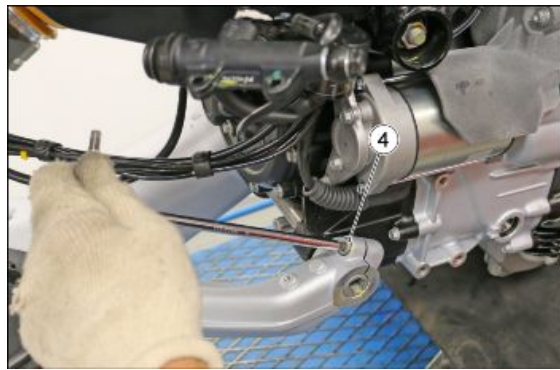

- Unscrew the swingarm pivot (5).

During refitting, tighten the pin of the swingarm to the prescribed torque.

Locking torques (N*m)

Swingarm pin 65 ± 9.5 Nm (47.94 ± 7.01 lb ft)



- Support the swingarm and remove the pin (5).



- Remove the swingarm from the vehicle, sliding the cardan shaft (6) inside.

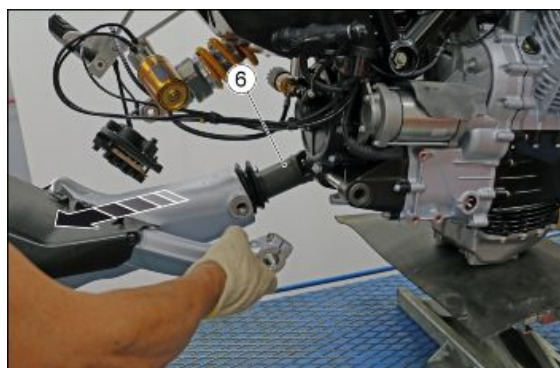

Cardan shaft

Removing

- First remove the rear wheel, the bevel gear and the swingarm.
- Using a suitable tool, apply force on the gearbox output shaft (1) in order to release the cardan shaft (2) from the gearbox output shaft spline.



Checking

Carefully check:

The splines (1) of the cardan shaft must be intact, without grainings or dents.

Check that the joint (2) is not hardened or excessively loose, in which case the complete cardan shaft must be replaced.

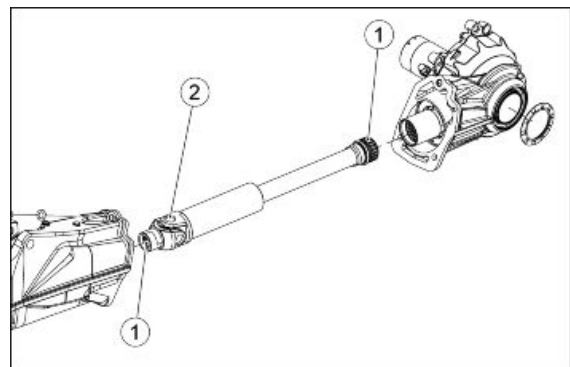

In the figure are shown two worn tothing profiles:

- Profile (3) shows acceptable wear, the cardan shaft should not be replaced.
- Profile (4) shows unacceptable wear, the cardan shaft must be replaced.

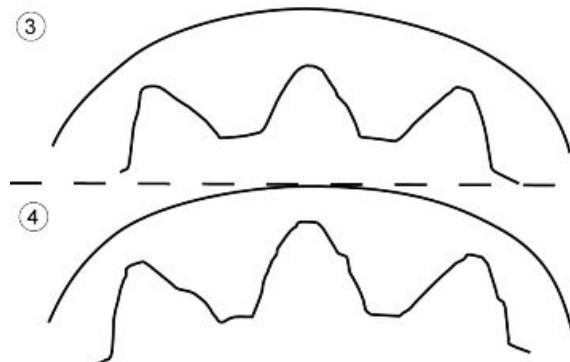

Bevel gears

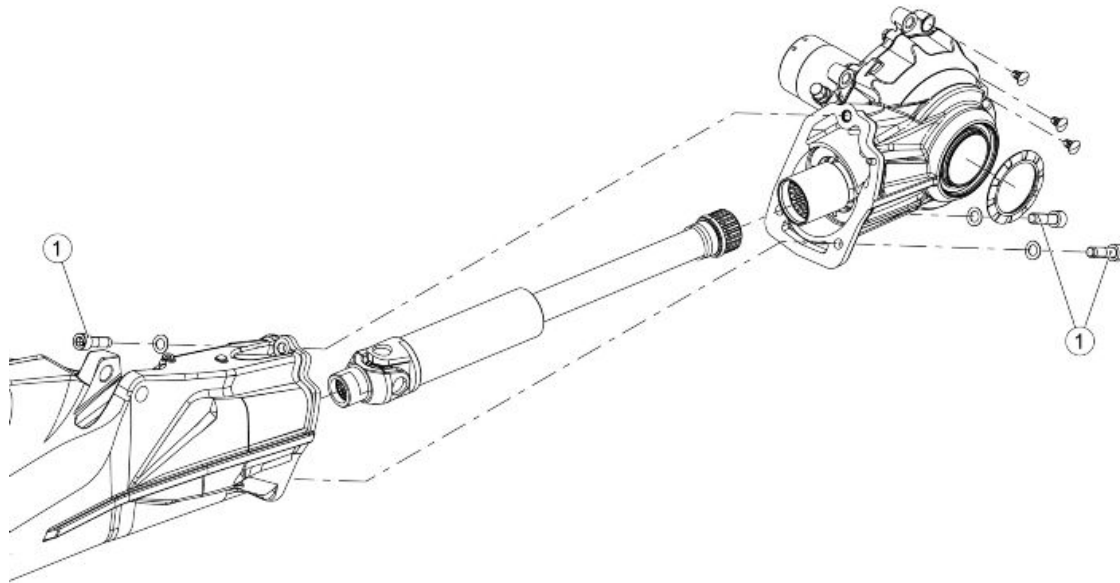

BEVEL GEAR

Pos.	Description	Type	Quantity	Torque	Notes
1	Bevel gear fixing screws	M10	3	45 ± 6.5 Nm (33.19 ± 4.79 lb ft)	-

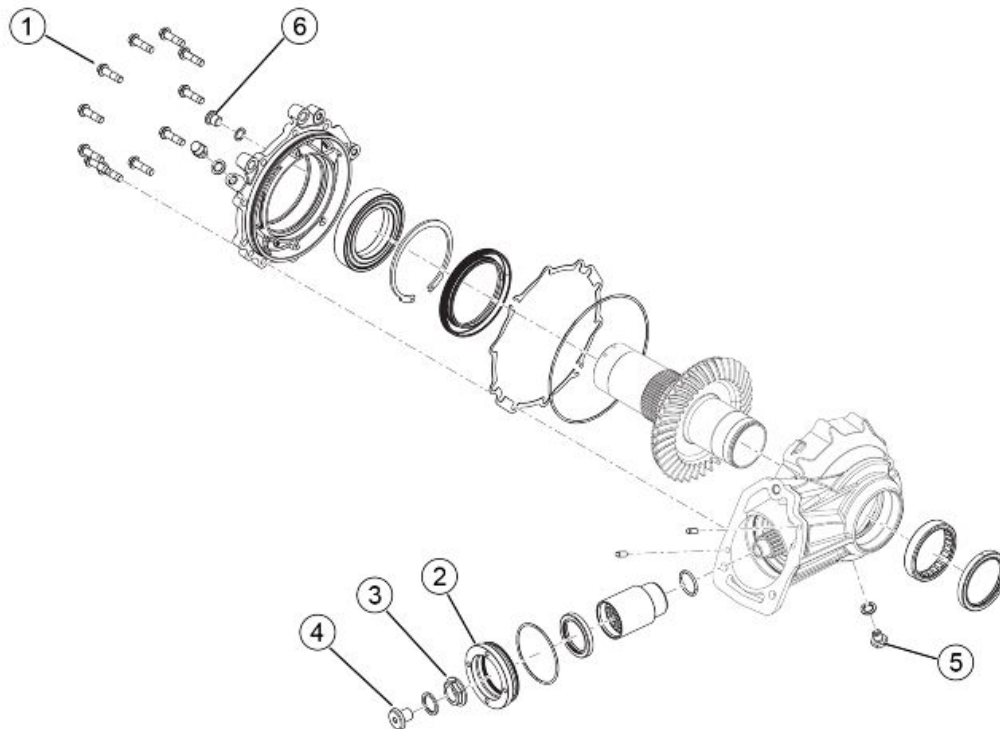

REAR WHEEL TRANSMISSION - COMPONENTS

Pos.	Description	Type	Quantity	Torque	Notes
1	Fixing screw for rear gearbox cover	M8x1	11	25 Nm (18.43 lb ft)	Screws with pre-applied threadlocker
2	Pinion fixing ring nut	-	1	140 Nm (103.25 lb ft)	With Loctite 243
3	Flanged nut fixing pinion	M20x1	1	100 Nm (73.75 lb ft)	With Loctite 243
4	Pinion fastening cap	M14x1	1	50 Nm (36.87 lb ft)	With Loctite 243
5	Oil drainage plug	M10x1.5	1	30 Nm (22.1 lb ft)	-
6	Oil load cap	M12x1.5	1	25 Nm (18.43 lb ft)	-

CAUTION

SINCE THE BEVEL GEAR IS A SAFETY COMPONENT, IT IS STRICTLY FORBIDDEN TO PERFORM ANY PINION/SPROCKET CLEARANCE ADJUSTMENTS FOR THE ENTIRE DURATION OF THE COMPONENT'S SERVICE LIFE. IF THE CLEARANCE IS NOT WITHIN THE REQUIRED TOLERANCE, THE ENTIRE BOX WILL HAVE TO BE REPLACED.

IF OIL LEAKAGES ARE DETECTED ON THE SPROCKET SIDE, REPLACE THE OIL SEALS ACCORDING TO THE DESCRIPTION BELOW.

Removing

- Place a pantograph jack under the engine to lift the rear wheel, and secure the vehicle so that it is stable and cannot fall.
- First remove the wheel and the rear brake disc.
- Remove the fixing screw (1) of the ABS sensor (2).

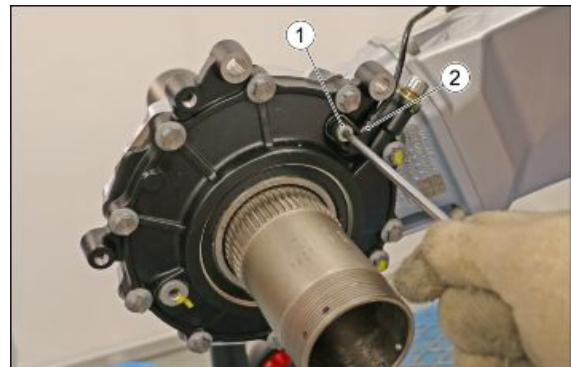

To avoid damaging the vehicle, place a protection between the jack and the sump oil.

- Remove the ABS sensor (2) from the bevel gear.



- Remove the upper fastener screw (3).

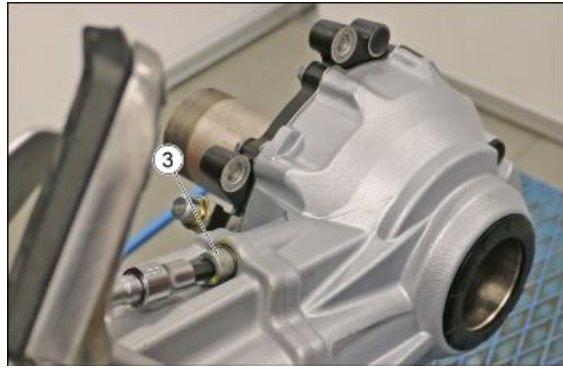

- Remove the two lower fixing screws (4).



- Remove the bevel gear from the rear swingarm.



Removal

CAUTION

CARRY OUT OIL DRAINING AND PROCEED WITH THE REMOVAL OF THE BREATHER BEFORE DISASSEMBLING THE GEARBOX.

NOTE

THE PICTURES OF THE SPECIFIC TOOL, CODE 021066Y, AND THE POSITIONING OF THE GEARBOX ARE INDICATIVE; HOWEVER, THE FOLLOWING PROCEDURE IS CORRECT.

Place the specific tool in a vice and secure it properly.

Specific tooling

021066Y Gearbox mounting

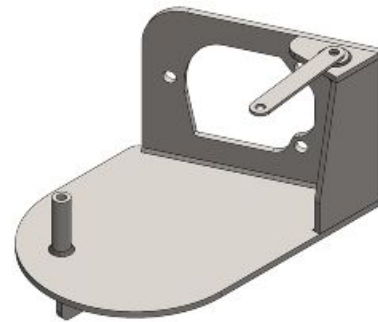
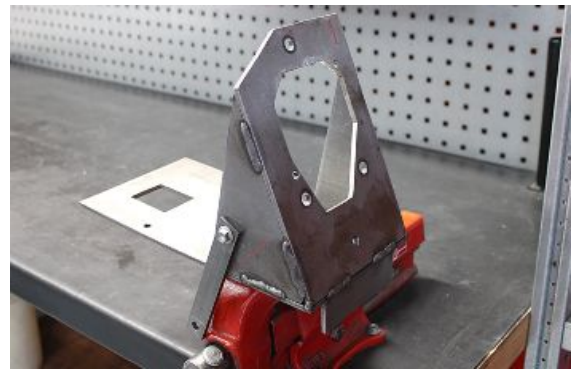

Place the complete gearbox on the specific tool.

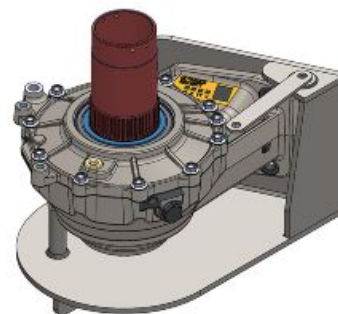

Use the screws to secure the complete gearbox to the swingarm and lock the gearbox to the specific tool.

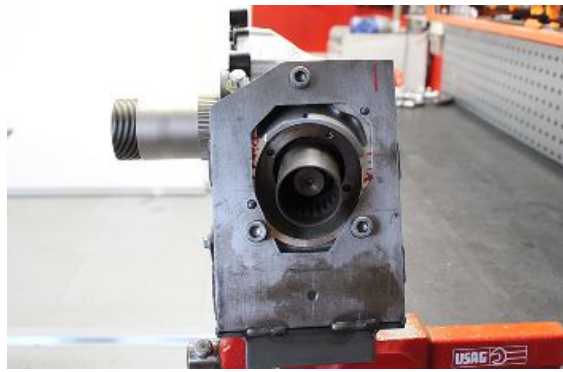

Pay attention because the lower screws are equipped with a locking nut.

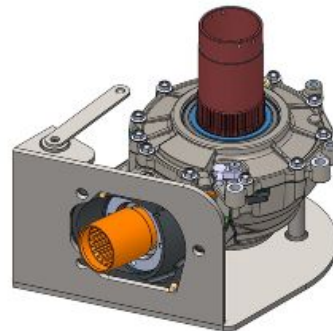

Insert the supplied flange with the specific tool on the sprocket hub, bringing it into contact with the case cover.



Screw the specific tool arm onto the flange.

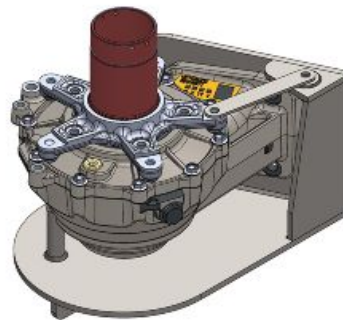
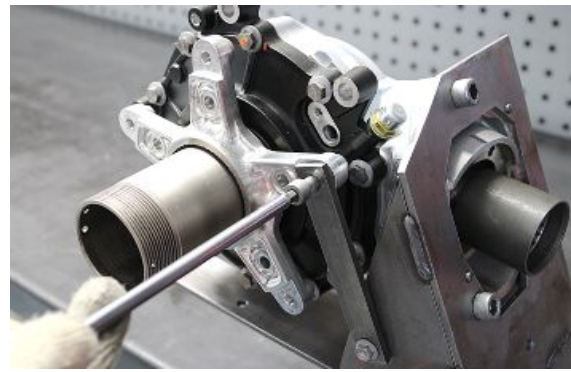

Heat the sleeve seat using an air heater.

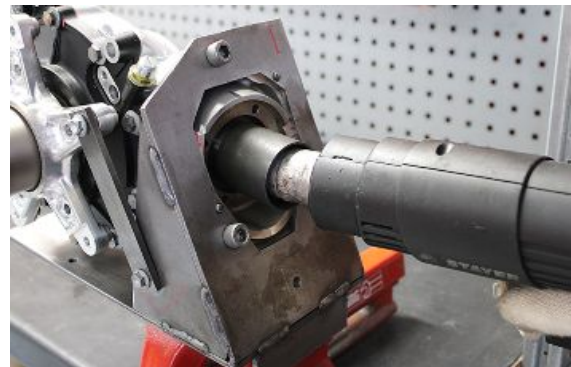

Unscrew the pinion fixing cap.



Remove the shim underneath the cap.

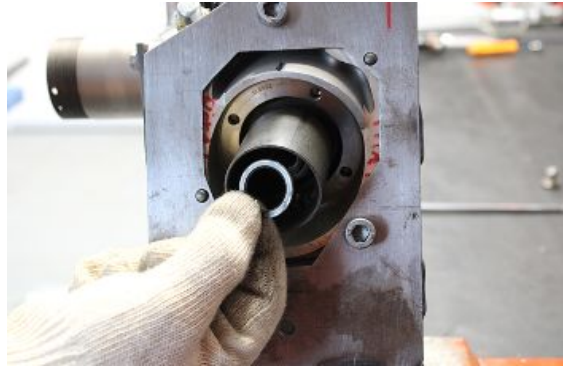

Reheat the sleeve seat using an air heater.

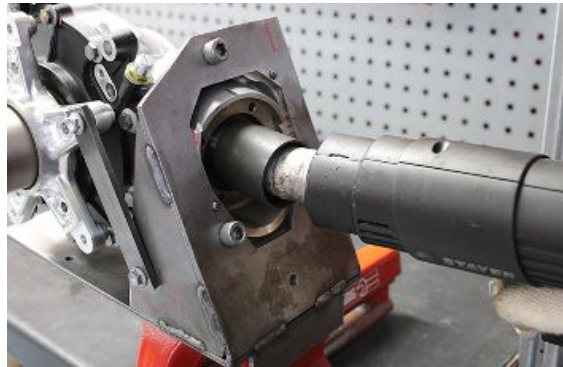

Unscrew the pinion fixing flanged nut.



Remove the flanged nut.



Extract the sleeve.



Heat the seat of the ring nut using an air heater.



To remove the ring nut, use the specific tool by inserting the relevant bolts into the holes in the ring nut.

Specific tooling

021067Y Pinion side fixing ring nut socket



Make sure to bring the specific tool to a stop on the ring nut.



Using the specific tool, unscrew the ring nut.



Remove the ring nut.



Separate the ring nut from the specific tool.



Remove the o-ring from the pinion.



Remove the oil seal from the ring nut.



Remove the sealing ring from the ring nut by tapping with a suitable punch.



Unscrew the arm of the specific tool to release the flange.

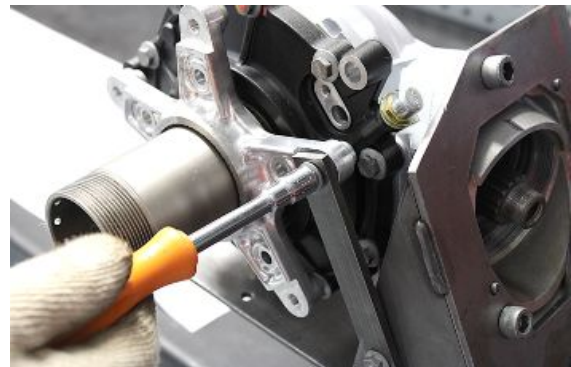

Remove the supplied flange with the specific tool from the sprocket hub.



Unscrew the fixing screws of the gearbox cover.



Using a rubber hammer, slightly separate the cover from the case so that the shims can be removed.



Remove the first shim.



Remove the second shim.



Remove the complete sprocket hub with the cover from the gearbox.

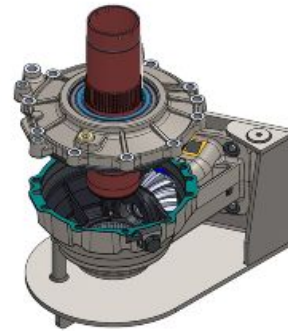

Remove the o-ring from the sprocket hub.



Position the complete sprocket hub with gearbox cover in a suitable press, using suitable supports.

WARNING

BEFORE USING THE PRESS, ENSURE THAT THE SUPPORTS USED REST EVENLY ON THE SURFACE OF THE COVER IN ORDER TO PREVENT DAMAGE TO COMPONENTS.

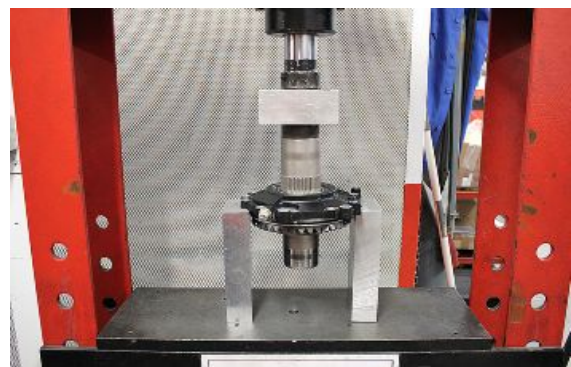

Operate the press in order to disassemble the case cover from the sprocket hub.

WARNING**NOTE**

BEFORE USING THE PRESS TO DISASSEMBLE THE SPROCKET HUB FROM THE COVER, IT IS RECOMMENDED THAT THE INVOLVED AREA BE HEATED WITH AN AIR HEATER IN ORDER TO FACILITATE DECOUPLING.



Remove the sealing ring from the gearbox cover.



Remove the gearbox from the specific tool and the vice.

Remove the sealing ring from the case by tapping with a suitable punch.



Using the specific tool, remove the roller bearing from the gearbox.

Specific tooling

021068Y Ring gear side roller cage extraction punch



Checking

- After assembly of the box, it is necessary to check the play between the pinion and the crown. Clamp in a vice and install a dial gauge by means of a suitable support. The dial gauge tester must be placed the outer end of a tooth positioned at 90°.

Characteristic

Maximum clearance allowed

0.08-0.2 mm (0.059-0.147 in)

- If the measured play is not compliant with the permitted values, proceed to the correction by selecting and replacing an adequate rear sprocket axle thickness.

Assembling

Using the specific tool, insert a new roller bearing in the gearbox, making sure to bring it up to its stop.

WARNING

WHEN REASSEMBLING, ALWAYS REPLACE THE ROLLER BEARING WITH A NEW ONE.

Specific tooling

021068Y Ring gear side roller cage extraction punch



Turn the gearbox upside down and apply grease between the roller bearing and the seal ring seat. Position a new sealing ring, making sure to bring it up to its stop using the special tool mentioned above.

WHEN REASSEMBLING, ALWAYS REPLACE THE SEALING RING WITH A NEW ONE.



Insert a new sealing ring in the gearbox cover, making sure to bring it up to its stop using a rubber hammer.

WHEN REASSEMBLING, ALWAYS REPLACE THE SEALING RING WITH A NEW ONE.

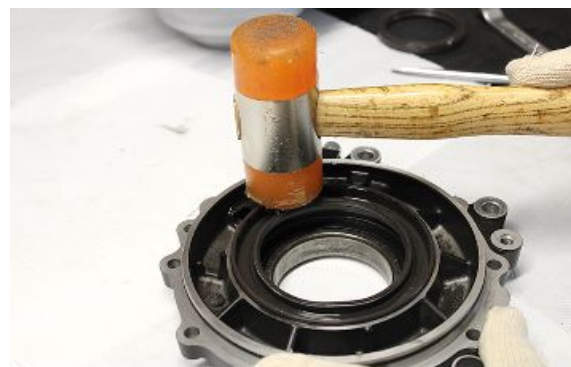

Insert the gearbox cover on the sprocket hub.
Position the complete sprocket hub with gearbox cover in a suitable press, using suitable supports.

WARNING

BEFORE USING THE PRESS, ENSURE THAT THE SUPPORTS USED REST EVENLY ON THE SURFACE OF THE COVER IN ORDER TO PREVENT DAMAGE TO COMPONENTS.



Operate the press in order to assemble the case cover from the sprocket hub.

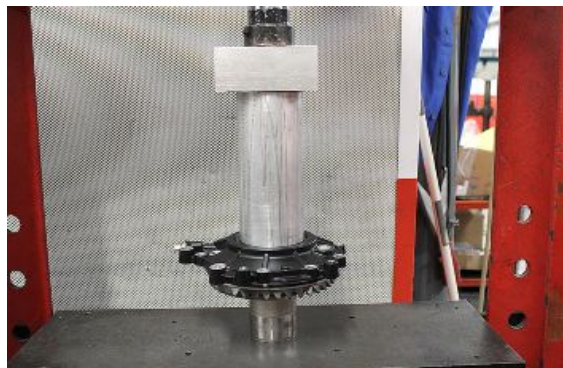

Insert a new o-ring on the sprocket hub.



Lubricate the bevel gear teeth during assembly.



Place the first shim on the mating surface with the cover, aligning it with the profile of the case itself.



Place the second shim with the inscription on the upper side.



Insert the complete sprocket hub with the cover into the gearbox.

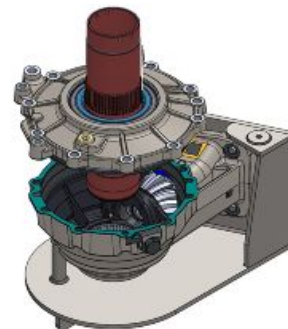

Insert all fixing screws on the case cover.



Tighten the screws to the prescribed torque, observing a crosswise sequence.

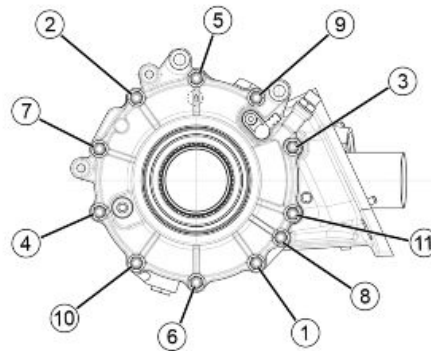

Place the specific tool in a vice and secure it properly.

Specific tooling

021066Y Gearbox mounting

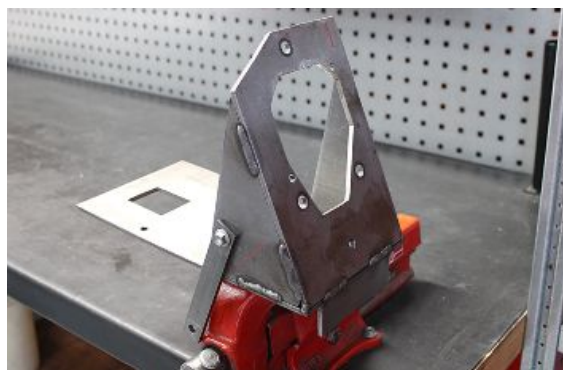

Place the complete gearbox on the specific tool.
Use the screws to secure the complete gearbox to the swingarm and lock the gearbox to the specific tool.

Pay attention because the lower screws are equipped with a locking nut.

Insert a new o-ring on the pinion, lubricating it before assembly.



CHECK THAT THE NEW O-RING IS COMPLETELY SEATED AROUND ITS PERIMETER.

Insert a new sealing ring inside the ring nut, making sure to bring it up to its stop.

WHEN REASSEMBLING, ALWAYS REPLACE THE SEALING RING WITH A NEW ONE.



Insert a new oil seal in the ring nut.



Insert the supplied flange with the specific tool on the sprocket hub, bringing it into contact with the case cover.



Screw the specific tool arm onto the flange.

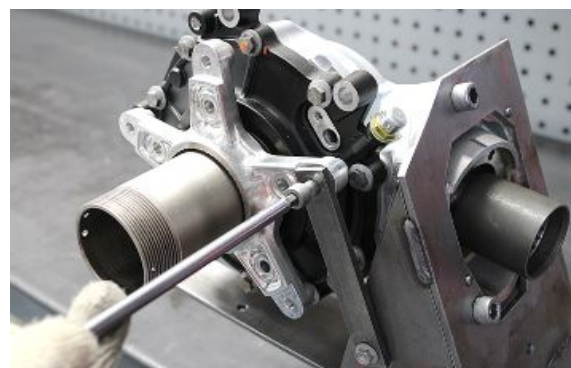

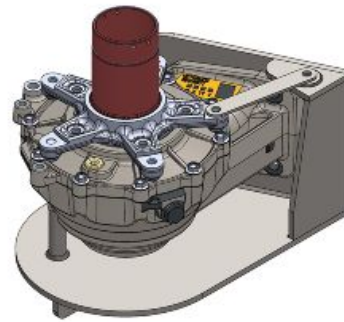

Clean the ring nut perfectly before assembly.
Use the specific tool by inserting the relevant bolts
in the holes of the ring nut.

Specific tooling

021067Y Pinion side fixing ring nut socket



Using the tool, insert the ring nut on the pinion.

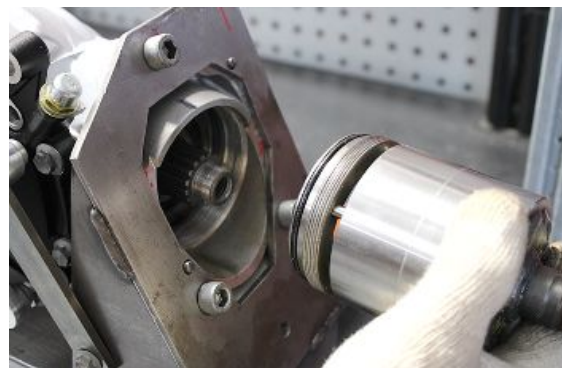

Using the specific tool, tighten the ring nut to the
prescribed torque.



Insert the sleeve.



Insert the flanged nut.



Tighten the pinion fixing flange nut to the prescribed torque.



Insert the shim with the chamfer facing the cap.



Make sure the shim is correctly positioned in its seat.

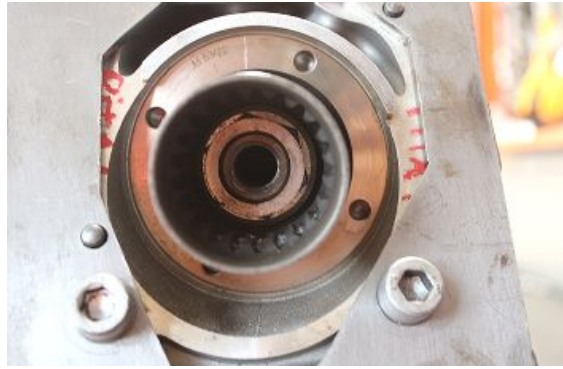

Insert the pinion fixing cap.



Tighten the pinion fixing cap to the prescribed torque.

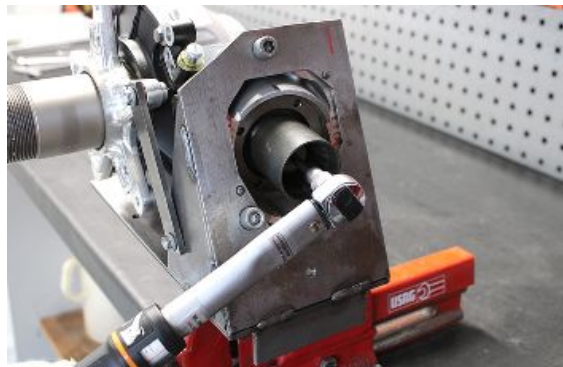

Unscrew the arm of the specific tool to release the flange.



Remove the supplied flange with the specific tool from the sprocket hub.



Installing

- Install the bevel gear on the swingarm, taking care to properly insert the cardan shaft in its splines.



- Insert the two lower fixing screws (4) and tighten them to the prescribed torque.

Locking torques (N*m)

Bevel gear fixing screw $45 \pm 6.5 \text{ Nm}$ ($33.19 \pm 4.79 \text{ lb ft}$)



- Insert the upper fixing screw (3) and tighten it to the prescribed torque.

Locking torques (N*m)

Bevel gear fixing screw $45 \pm 6.5 \text{ Nm}$ ($33.19 \pm 4.79 \text{ lb ft}$)

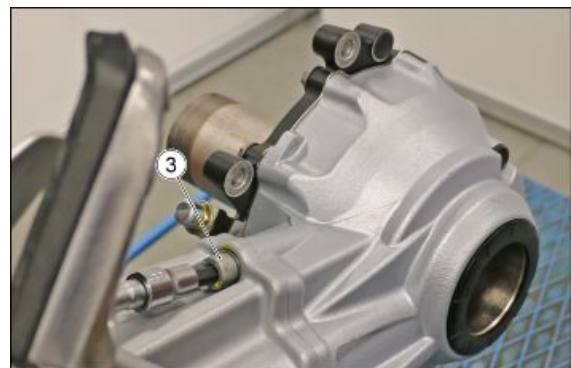

- Insert the ABS sensor (2) in the corresponding seat on the bevel gear.

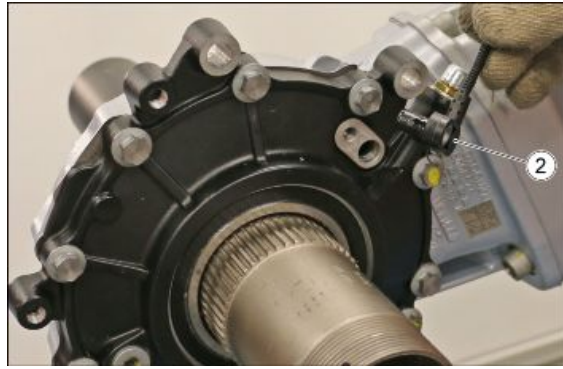

- Tighten the fixing screw (1) of the ABS sensor (2).

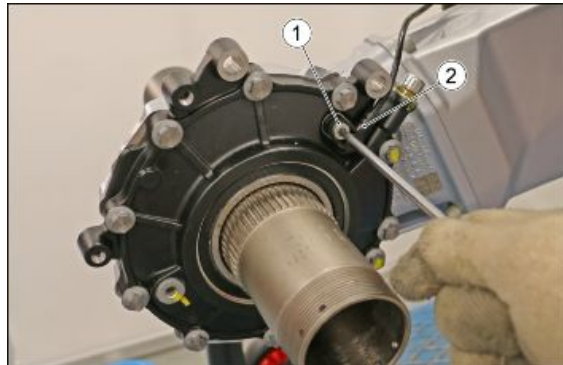

- Top up the oil following the instructions in the "Maintenance / Transmission oil / Replacement" chapter

See also

[Replacement](#)

Stand

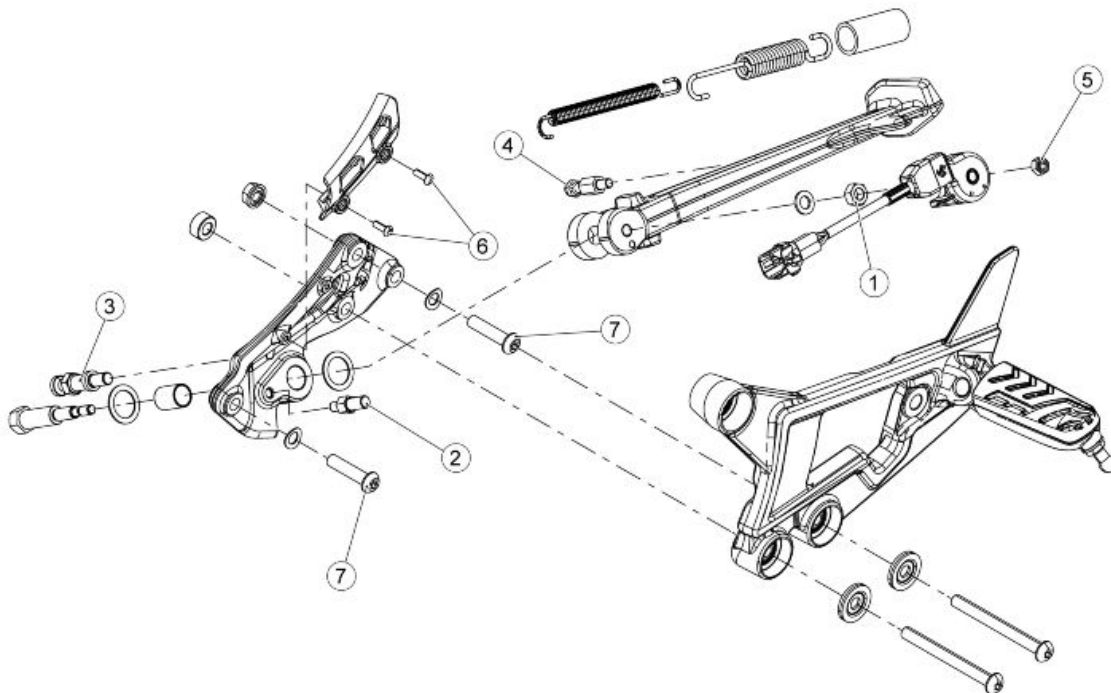

STAND						
Pos.	Description	Type	Quantity	Torque	Notes	
1	Nut for fastening the stand to the stand plate	M8	1	25 ± 3.5 Nm (18.44 ± 2.58 lb ft)	-	
2	Stand switch lock pin	M6	1	10 ± 2 Nm (7.38 ± 1.48 lb ft)	Pre-applied Loct. 243	
3	Pin fastening the spring to the stand plate	M8	1	25 ± 5 Nm (18.44 ± 3.69 lb ft)	Pre-applied Loct. 243	
4	Pin fastening the spring to the stand	M6	1	10 ± 2 Nm (7.38 ± 1.48 lb ft)	-	
5	Stand switch fixing nut	M6	1	10 ± 2 Nm (7.38 ± 1.48 lb ft)	-	
6	Stand sensor cable guard fixing screws	M5	2	5.5 ± 1 Nm (4.06 ± 0.74 lb ft)	Pre-applied Loct. 243	
7	Screws fastening the stand plate to the engine crankcase	M8	2	25 ± 3.5 Nm (18.44 ± 2.58 lb ft)	-	

Side stand

REMOVAL

- First remove the left rider footrest plate.
- Remove the two fixing screws and remove the protection of the stand switch.
- Cut the plastic clamp.

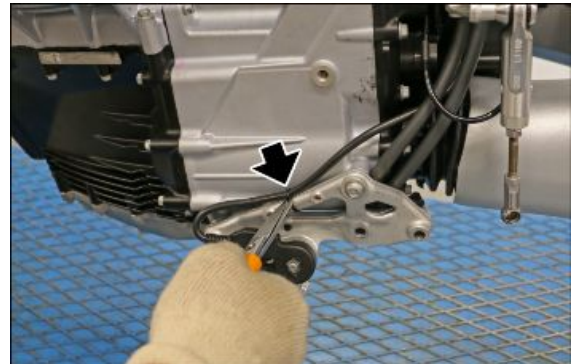

- Remove the nut (1).



- Remove the switch from the side stand.



- Remove the two fastening screws (2).

During refitting, tighten the fixing screws to the prescribed torque.

Locking torques (N*m)

Side stand fixing screw 25 ± 3.5 Nm (14.75 ± 2.58 lb ft)

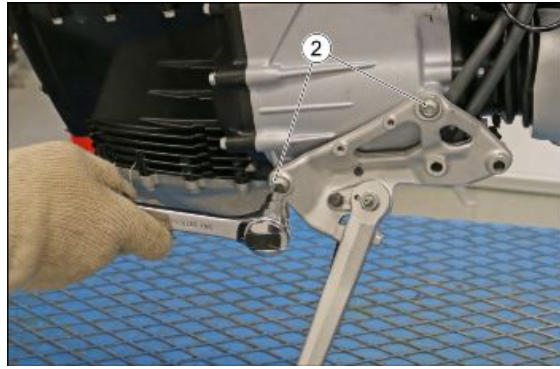

- Remove the stand and the corresponding support from the vehicle.



Exhaust

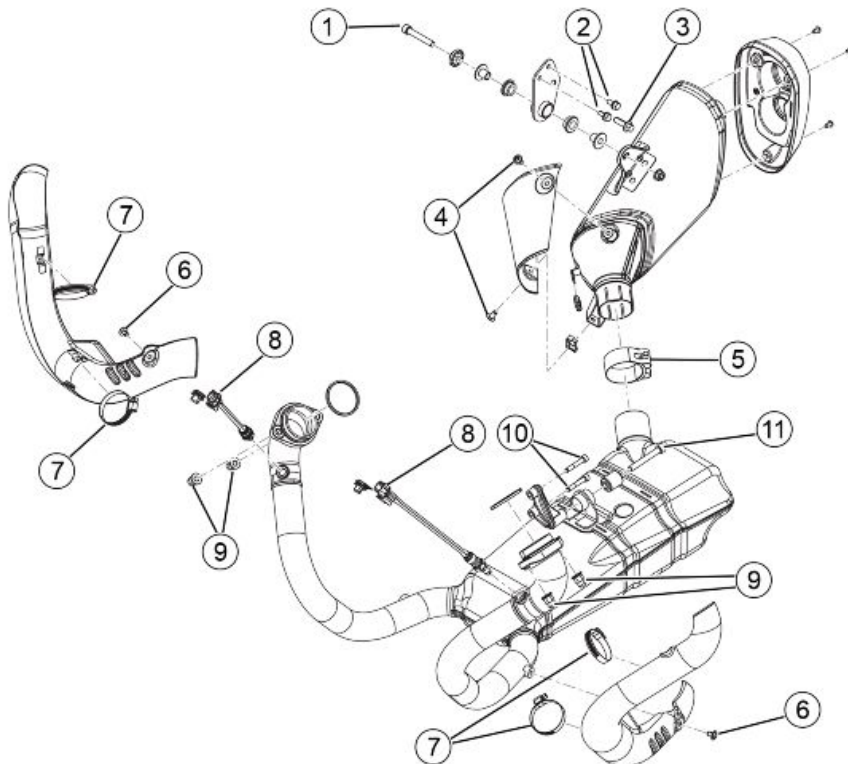

SILENCER

Pos.	Description	Type	Quantity	Torque	Notes
1	Screw fastening outer silencer support bracket	M8	1	25 ± 5 Nm (18.43 ± 3.68 lb ft)	-
2	Upper silencer fixing screw to the footrest	M6	2	10 ± 2 Nm (7.37 ± 1.47 lb ft)	-
3	Lower silencer fixing screw to the footrest	M8	1	25 ± 5 Nm (18.43 ± 3.68 lb ft)	-
4	Fixing screw for silencer manifold protection	M6	2	10 ± 2 Nm (7.37 ± 1.47 lb ft)	Screw with pre-applied threadlocker
5	Fastening the silencer to the exhaust manifold	Pipe clamp	1	25 ± 5 Nm (18.43 ± 3.68 lb ft)	-
6	Heat shield protection fastening screws	M6	2	10 ± 2 Nm (7.37 ± 1.47 lb ft)	Screw with pre-applied threadlocker
7	Heat shield protection fixing	Pipe clamp	4	3 ± 0.6 Nm (2.21 ± 0.44 lb ft)	-
8	Lambda probe fastener	M12x1.25	2	25 ± 5 Nm (18.43 ± 3.68 lb ft)	-
9	Exhaust manifold flange fastening nuts	M8	4	25 ± 5 Nm (18.43 ± 3.68 lb ft)	-
10	Fixing screw for silencer support outer bracket	M6	2	10 ± 2 Nm (7.37 ± 1.47 lb ft)	-
11	Lower fixing screw for exhaust manifold	M8	1	25 ± 5 Nm (18.43 ± 3.68 lb ft)	-

Removing the tail pipe**REMOVAL**

- Undo the two fixing screws (1) and remove the heat shield (2).

During refitting, tighten the fixing screws to the prescribed torque.

Locking torques (N*m)

Heat shield fixing screw (1) 10 Nm (7.38 lbf ft)

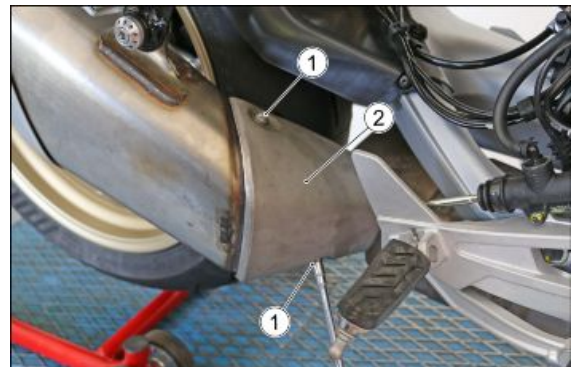

- Unscrew the clamp fastening the terminal to exhaust pipe.

During refitting, tighten the clamp to the prescribed torque.

Locking torques (N*m)

Exhaust terminal clamp 25 Nm (18.44 lbf ft)



- Remove the screw and its fixing lock nut used to fasten the terminal to the frame.

During refitting, tighten the fixing screw to the prescribed torque.

Locking torques (N*m)

Support bracket terminal fastener 25 Nm (18.44 lbf ft)



- Remove the exhaust terminal from the vehicle.



Removing the exhaust manifold

EXHAUST MANIFOLD HEAT SHIELD

Unscrew the lower fixing screw of the heat shield.

NOTE

THESE OPERATIONS ARE ALSO VALID FOR THE HEAT SHIELD ON THE OPPOSITE SIDE.



Unscrew the upper clamp located inside the heat shield.

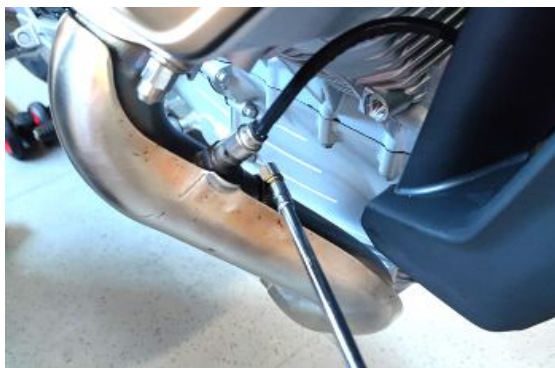

Unscrew the lower calmp located inside the heat shield.

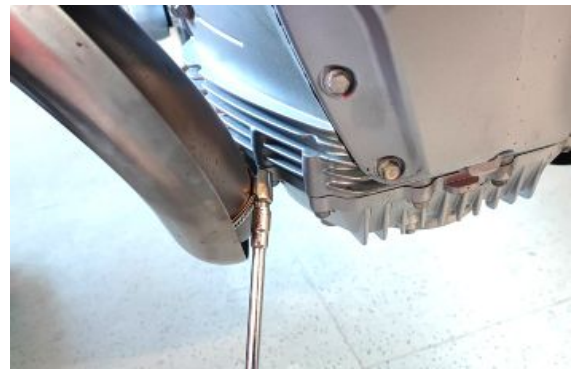

Remove the heat shield from the exhaust manifold by loosening the metal calmps.



When reassembling, loosen the calmps and place the heat shield on the manifold.

Tighten the upper and lower clamps and the fixing screw to the prescribed torque.

WARNING



DURING REASSEMBLY, USE NEW METAL CLAMPS.

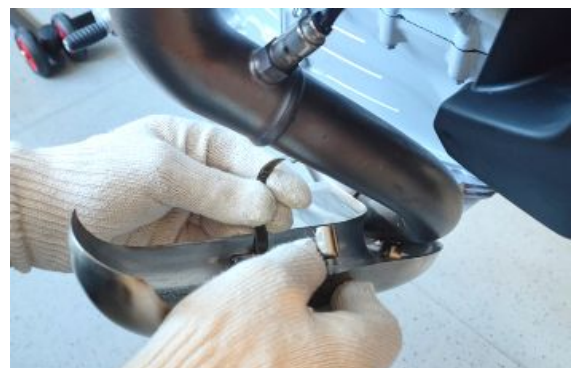

- Remove the exhaust end first.
- Disconnect the lambda probe connector (1) on both sides.



- Remove the two nuts (2) of the exhaust flange, on both heads.

During refitting, tighten the nuts to the prescribed torque.

Locking torques (N*m)

Exhaust flange fixing nut 25 ± 4 Nm (14.75 ± 2.95 lbf ft)



- Remove the lower fastener screw (3).

During refitting, tighten the screw (3) to the prescribed torque.

NOTE

Once tightened to torque, the fastening screw (3) must project by of 5 -10 mm from the exhaust support. This is to compensate for the metal deformations due to heat.

Locking torques (N*m)

Lower screw fastening the exhaust manifold 25 ± 4 Nm (14.75 ± 2.95 lbf ft)



- Remove the entire exhaust system from the vehicle.



- Retrieve the copper gasket (4) from both heads.



DURING REFITTING, USE NEW COPPER GASKETS.



INDEX OF TOPICS

BRAKING SYSTEM

BRAK SYS

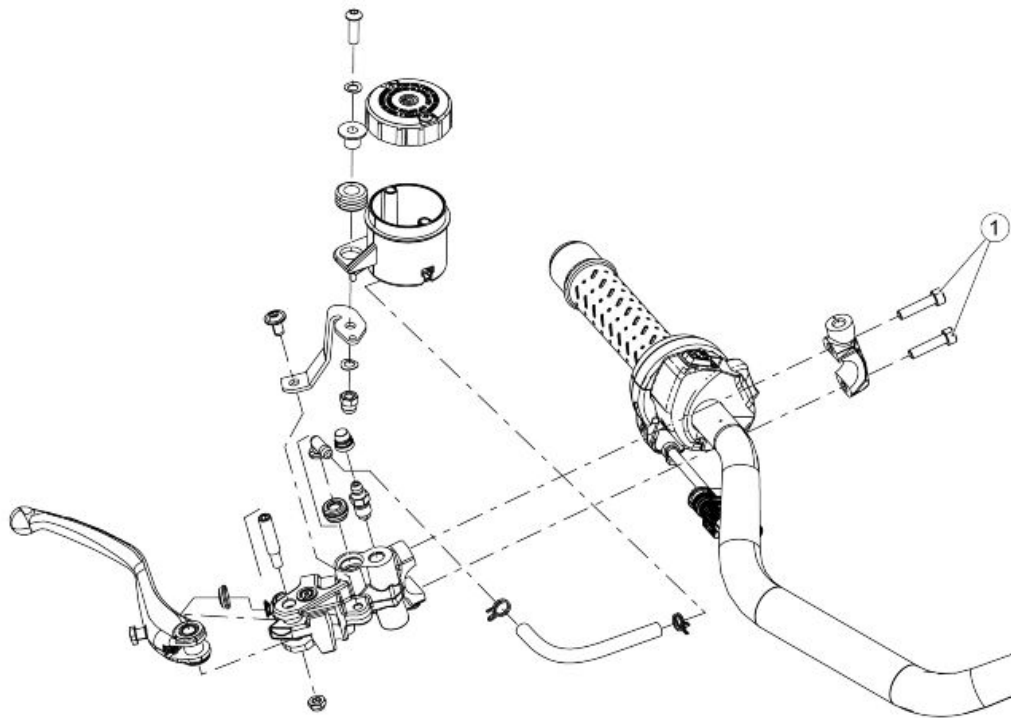

FRONT BRAKE MASTER CYLINDER

Pos.	Description	Type	Quantity	Torque	Notes
1	Screws fixing brake pump clamp to the handlebar	M6	2	10 ± 1.5 Nm (7.38 ± 1.11 lb ft)	-

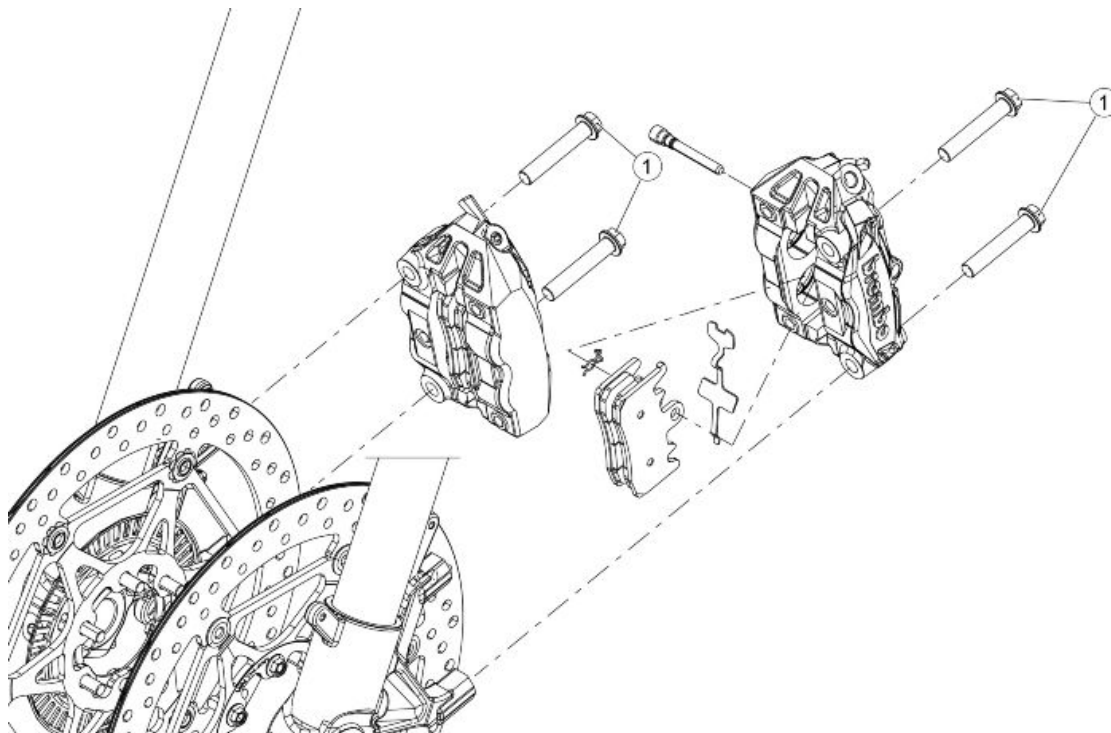

FRONT BRAKE CALLIPER

Pos.	Description	Type	Quantity	Torque	Notes
1	Screws fastening front brake calliper	M10x1.25	2+2	50 ± 5 Nm (36.88 ± 3.69 lb ft)	-

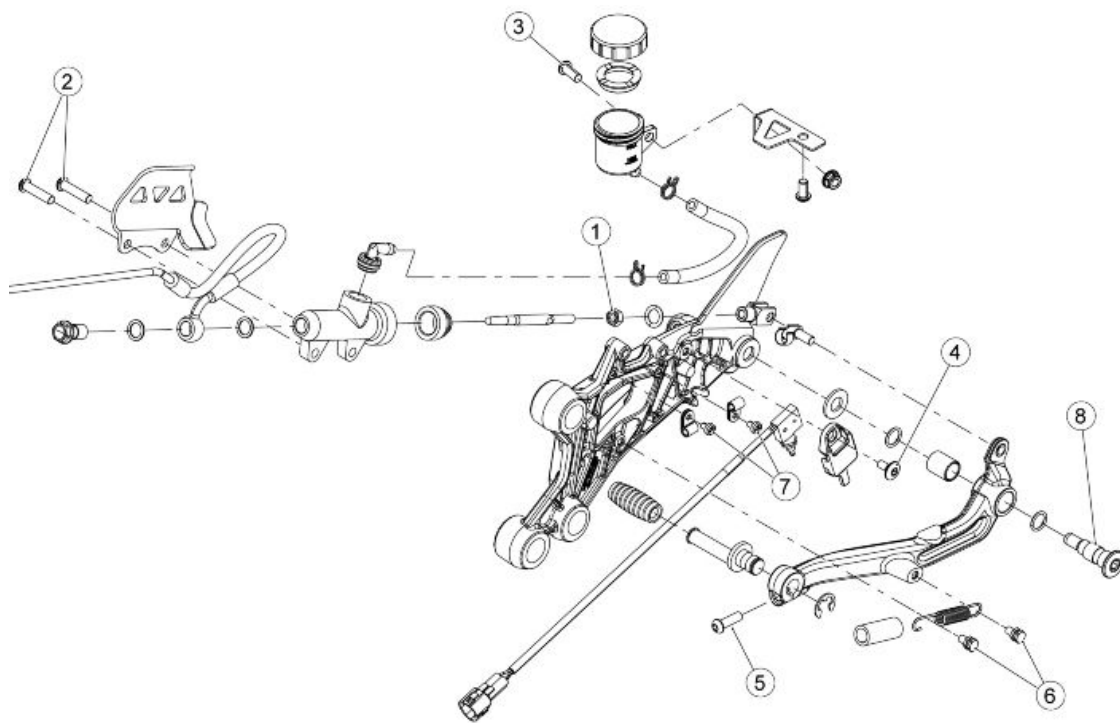

REAR BRAKE MASTER CYLINDER

Pos.	Description	Type	Quantity	Torque	Notes
1	Rear brake rod lock nut	M6	1	6 ± 1 Nm (4.23 ± 0.74 lb ft)	-
2	Rear brake pump fastening screws	M6	2	10 ± 1.5 Nm (7.38 ± 1.11 lb ft)	-
3	Brake oil tank fixing screw	M6	1	6 ± 1 Nm (4.23 ± 0.74 lb ft)	-
4	Brake switch fixing screw	M5	1	6 ± 1 Nm (4.23 ± 0.74 lb ft)	-
5	Rear brake lever rod screw	M6	1	8 ± 1 Nm (5.90 ± 0.74 lbf ft)	-
6	Spring coupling pin for brake lever	M5	2	6 ± 1 Nm (4.43 ± 0.74 lbf ft)	-
7	Brake switch cable gland	M4	2	3 ± 0.5 Nm (2.21 ± 0.37 lbf ft)	-
8	Rear brake lever fixing pin	M8	1	25 ± 3.5 Nm (18.44 ± 2.58 lbf ft)	-

REAR BRAKE CALLIPER

Pos.	Description	Type	Quantity	Torque	Notes
1	Rear brake calliper fixing screws	M10	2	50 ± 5 Nm (36.88 ± 3.69 lb ft)	-

Interventions rules

CAUTION

THE FRONT BRAKE DISC SHAPE DOES NOT CHANGE THE OPERATING AND MAINTENANCE SPECIFICATIONS OF THE SYSTEM.

ABS

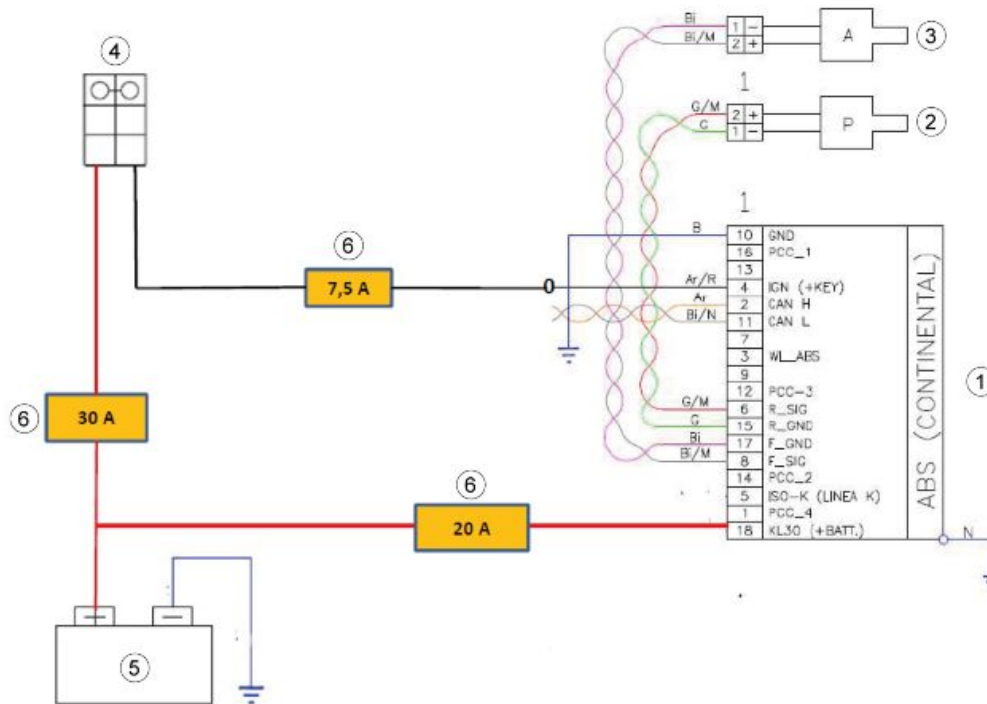

ABS CONTROL UNIT

Key:

1. ABS control unit
2. Rear ABS sensor
3. Front ABS sensor
4. Ignition switch
5. Battery
6. Fuse

Modulator

REMOVAL

- Drain the brake system completely.
- First remove the fuel tank, the air filter housing, the radiator and the expansion tank.
- Unscrew the fittings of the brake pipes from the ABS modulator.

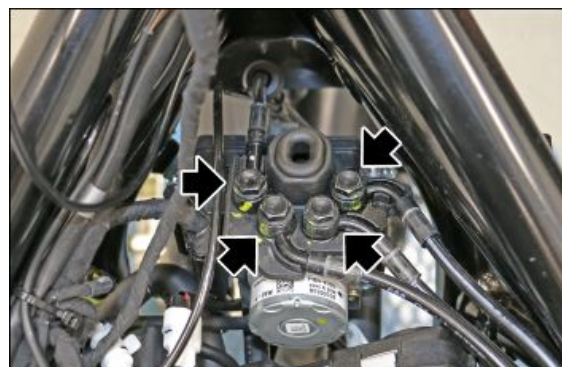

- Remove the joints and collect the sealing washers from each pipe.



DURING REFITTING, USE NEW SEALING WASHERS.

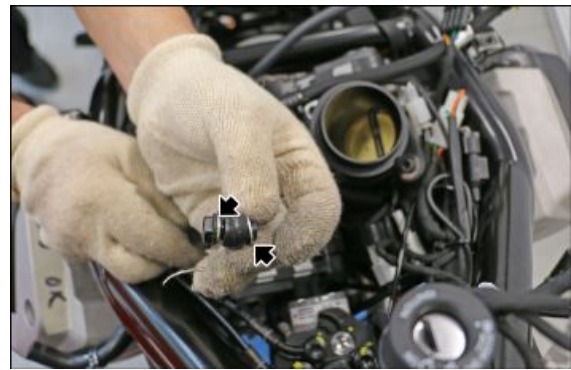

- Remove the jig (1) for pipe positioning from the ABS modulator.

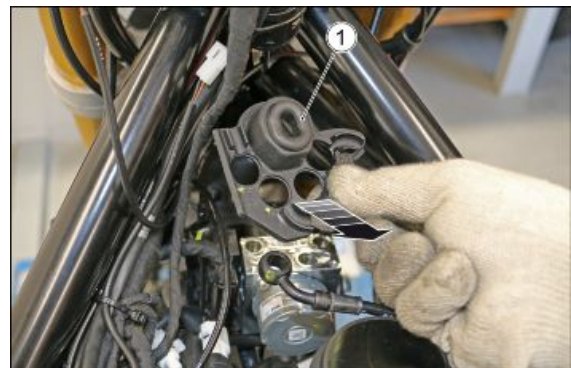

- Remove the lower fixing nut (2).



- Remove the ground cable (3) from the lower fixing of the modulator.



- Remove the lateral fastener screw (4).

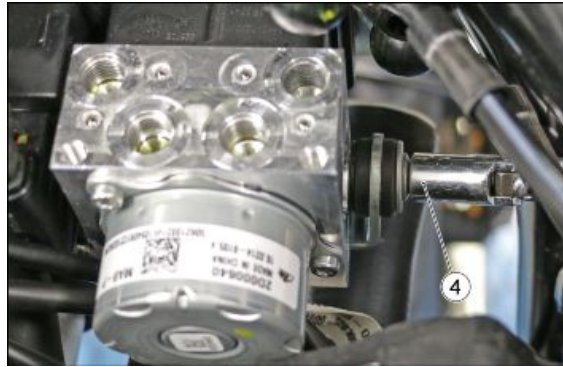

- Remove the ABS modulator from its seat.
- Press the safety tab and push the connector locking lever (5) forward.



- Disconnect the modulator connector.

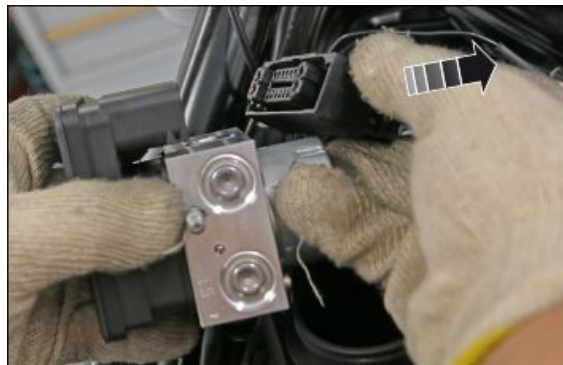

- Remove the modulator from the vehicle.

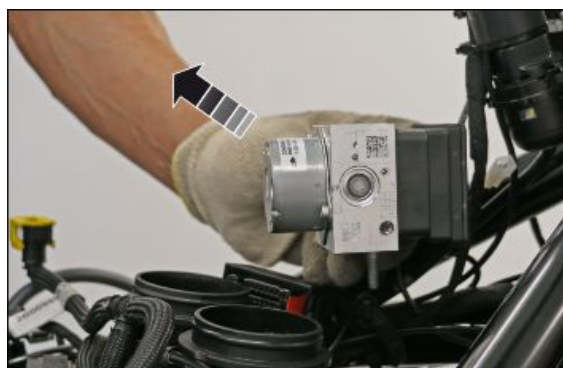

INSTALLATION

- Install the new modulator unit, complete with ABS control unit, completely pre-filled with brake fluid and with the connection mounting holes closed with protective plugs
- To keep the brake fluid in the ABS control unit, first remove the protective plugs from the feed holes to the brake callipers, then connect the corresponding pipes

- Once the brake calliper pipes are connected, remove the protective caps from the inlet ports from the brake pumps and connect the respective pipes to the ABS modulator
- Remove the plugs of the brake pump tanks and fill them with new brake fluid

CAUTION

PERFORM THE STANDARD BRAKING SYSTEM BLEEDING PROCEDURE, AS DESCRIBED AT THE END OF THE CHAPTER.

- Fill the reservoirs and refit the caps
- Check the stroke and sensitivity of the front brake lever and the rear brake pedal
- If the brake pedal or lever stroke is too long after carrying out the bleeding procedure, check the braking system for leaks and, if none are found, bleed the system using the diagnostic tool, as described.
- Disconnect the flexible bleeder pipes and re-tighten the bleeder screws, applying the correct torque

ABS CONTROL UNIT CONNECTOR INSERTION PROCEDURE

- Check the initial position of the connection clip lever.

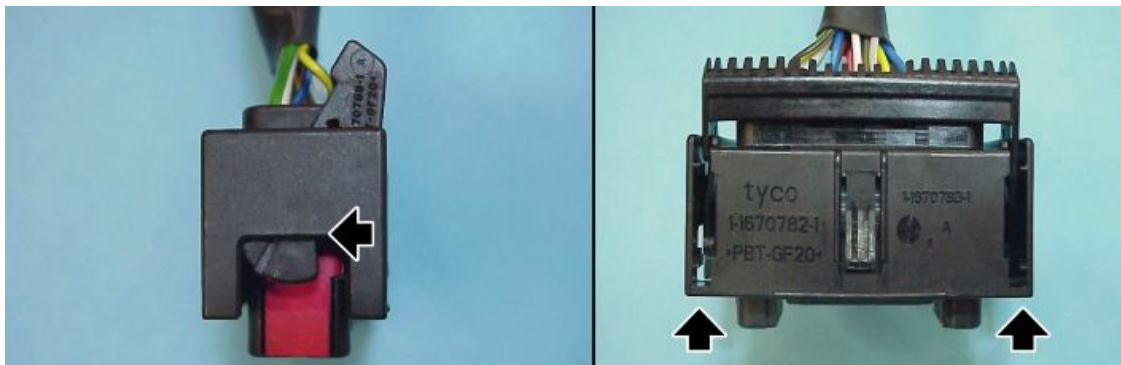

- When the connector is fully inserted, the distance between the connector and the ABS control unit must be 7.5 mm (0.29 in).

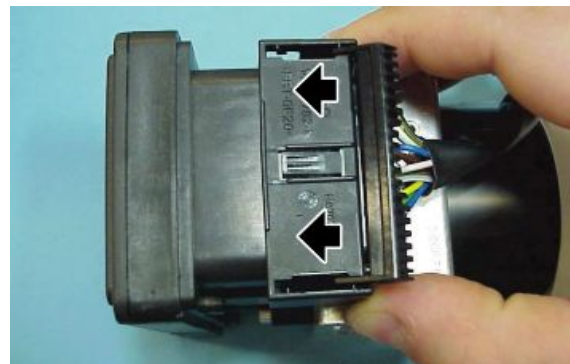

- If the initial position of the connector and the driving lever is not that shown in fig. 1, the connector will not be properly coupled and the distance measured will be greater (12 mm approx. (0.47 in)). In this case repeat the operation as described in the two previous points.

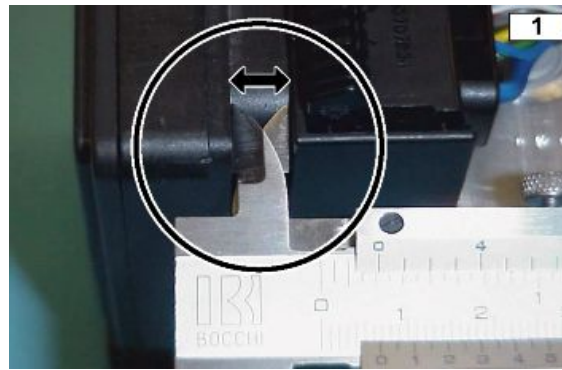

WE RECOMMEND CREATING A TEMPLATE IN ORDER TO ENSURE THAT THE CONNECTOR IS INSERTED CORRECTLY.

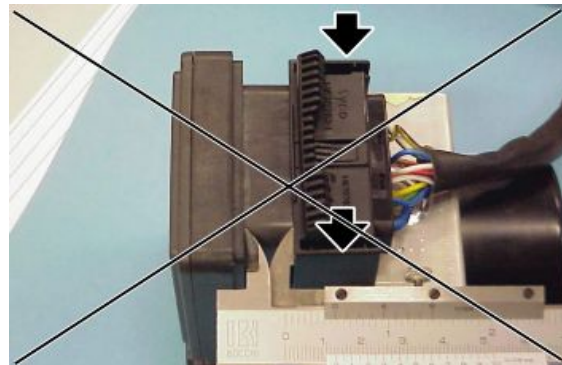

Component maintenance

- The vehicle is equipped with two-channel ABS that operates both on the front wheel and on the rear wheel. To do this, the system uses sensors and tone wheels on both wheels; the one on the rear wheel is integrated inside the bevel gear and does not require maintenance.
- It is important to check periodically and all times that the front wheel is refitted, the front sensor (1) or tone wheel (2) are replaced and that the distance is consistent over all 360°. Use a thickness gauge to check the distance between sensor (1) and tone wheel (2) at three points at a 120° span.



CAUTION

IF THE READINGS SHOULD RETURN A VALUE OUTSIDE OF THE FIELD OF TOLERANCE, REPLACE THE SENSOR AND/OR THE PHONIC WHEEL AND REPEAT THE CHECK IN ORDER TO ENSURE THAT THE VALUES FALL WITHIN THE FIELD OF TOLERANCE.

Characteristic

□□□□□□□□□□□□□□

0.5 - 2.4 □□□0.020 - 0.094 □□□

TONE WHEEL CLEANING

- It is important to check regularly that the front tone wheel is clean. If this is not the case, carefully remove any dirt using a cloth or a brush. Avoid using solvents or abrasive substances and do not direct air or water jets directly on the tone wheel.

REPLACING THE PHONIC WHEEL SENSOR

- Disconnect the front phonic wheel sensor connector from the main wiring harness. Unscrew and remove the screws and remove the phonic wheel sensor

CAUTION

BEFORE REFITTING, ENSURE THAT THE CONTACT SURFACES BETWEEN THE SENSOR AND THEIR SEATS ARE FREE OF IMPERFECTIONS AND PERFECTLY CLEAN. ALWAYS CHECK THE DISTANCE BETWEEN THE SENSOR AND THE PHONIC WHEEL.

Rear brake calliper

Removal

- Connect the bleed bottle to the calliper bleeder screw and open it.
- Fully depress the rear brake lever and secure it in place with a locking device to prevent brake fluid from flowing out of the open circuit.
- Close the calliper bleeder screw and remove the bleeder bottle.
- Unscrew the rear brake pipe union screw.



- Remove the screw from the brake pipe fitting and retrieve the two sealing washers.

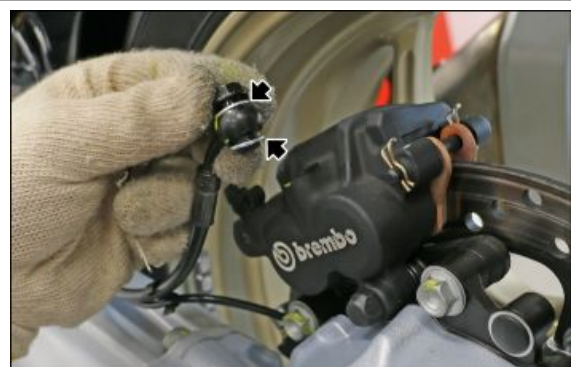

DURING REFITTING, USE NEW SEALING WASHERS.

- Remove the two rear brake calliper fixing screws (1).

During refitting, tighten the fixing screws to the prescribed torque.

NOTE

TO REMOVE THE BRAKE CALLIPER, IS NOT NECESSARY TO REMOVE THE REAR WHEEL.

Locking torques (N*m)

Brake calliper fixing screw 50 ± 5 Nm (36.88 ± 3.69 lbf ft)



- Remove the rear brake calliper from the vehicle.

NOTE

TO REMOVE THE BRAKE CALLIPER, IS NOT NECESSARY TO REMOVE THE REAR WHEEL.

**Installing**

- Completely insert the piston inside the calliper, so as to widen the brake pads.
- Install the brake calliper on the vehicle, inserting the brake disc inside.

NOTE

FOR THE INSTALLATION OF THE BRAKE CALLIPER, IT IS NOT NECESSARY TO REMOVE THE REAR WHEEL.



- Install the two fixing screws (1) and tighten them to the specified torque.

NOTE

FOR THE INSTALLATION OF THE BRAKE CALLIPER, IT IS NOT NECESSARY TO REMOVE THE REAR WHEEL.

Locking torques (N*m)

Brake calliper fixing screw 50 ± 5 Nm (36.88 ± 3.69 lbf ft)

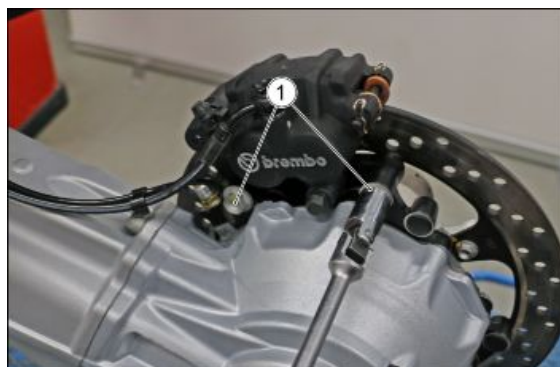

- Insert the screw and the associated seal washers in the brake pipe fitting, in the order shown in the figure.



DURING REFITTING, USE NEW SEALING WASHERS.



- Install the brake pipe on calliper and tighten the special screw of the fitting.



- Remove the brake oil tank cap and fill it with new brake fluid.

CAUTION

PERFORM THE STANDARD BRAKING SYSTEM BLEEDING PROCEDURE, AS DESCRIBED AT THE END OF THE CHAPTER.

- Top up the oil tank and refit the cap.
- Check the stroke and sensitivity of the brake pedal.
- If, after bleeding, the pedal travel is too long, check the brake system for leaks and, if all is well, bleed using the diagnostic tool as described.
- Disconnect the flexible bleeder pipes and re-tighten the bleeder screws, applying the correct torque.

Front brake calliper

Removal

NOTE

THE FOLLOWING PROCEDURE IS TO BE CONSIDERED VALID FOR BOTH FRONT BRAKE CAL-LIPERS.

- Using a rubber pipe, connect a container to the bleed screw (1) and loosen it to allow the fluid to flow.
- Press thoroughly the brake lever and lock it in position, in order to prevent fluid leakages from the brake pipe.
- Tighten the bleed screw (1) and remove the container.



- Remove the special screw (2) from the brake calliper and collect the sealing washers (3)

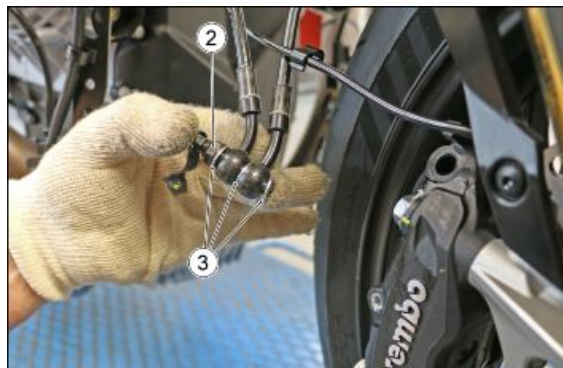

- Remove the fixing screws (4) and remove the brake calliper from the vehicle.



Installing

NOTE

THE FOLLOWING PROCEDURE IS TO BE CONSIDERED VALID FOR BOTH FRONT BRAKE CAL-LIPERS.

- Insert the brake calliper (5) on the disc and tighten the fixing screws (4) to the prescribed torque.

Locking torques (N*m)

Brake calliper fixing screw 50 ± 5 Nm (36.88 ± 3.69 lbf ft)



- Insert the special screw (2) in the brake pipe couplings using new sealing washers (3).

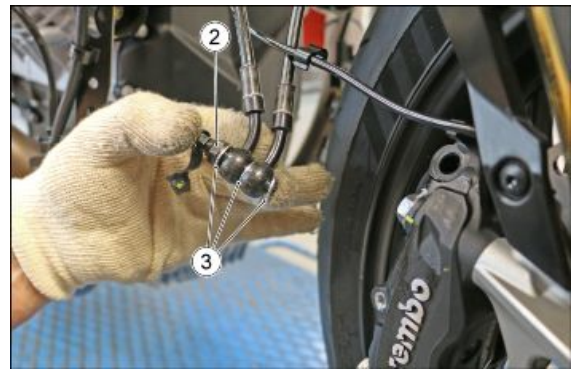

- Install the screw / joints assembly on the brake calliper and tighten the special screw (2).



- Remove the clamp from the front brake lever.
- Remove the brake fluid reservoir cap and fill it with new brake fluid

CAUTION

PERFORM THE STANDARD BRAKING SYSTEM BLEEDING PROCEDURE, AS DESCRIBED AT THE END OF THE CHAPTER.

- Top up the fluid reservoir and refit the cap
- Check the stroke and sensitivity of the brake lever
- If, after bleeding, the lever stroke is too long, check that there are no leaks in the braking system. If there are no leaks, proceed with bleeding operations using the diagnostic tool.
- Detach the hoses and tighten the bleed screws.

Rear brake disc

Removal

- First remove the rear wheel.
- Remove the two screws (1) fastening the rear brake calliper.

During refitting, tighten the fixing screws to the prescribed torque.

Locking torques (N*m)

Rear brake calliper fixing screw $50 \pm 5 \text{ Nm}$ ($36.88 \pm 3.69 \text{ lbf ft}$)

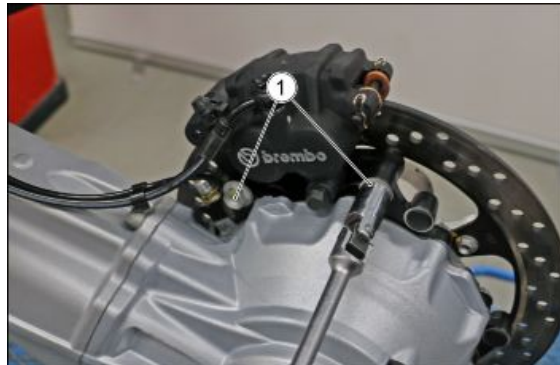

- Remove the brake calliper from the swingarm and fasten it to the vehicle, so as not to tighten the oil pipe and the wiring harness of the ABS sensor.



- Remove the rear brake disc together with the flange from the rear wheel hub.



- Unscrew the fixing screws (2) and remove the brake disc (3) from the support flange (4).



WHEN REFITTING, MAKE SURE THAT THE MARKINGS ON THE BRAKE DISC ARE FACING UPWARD.

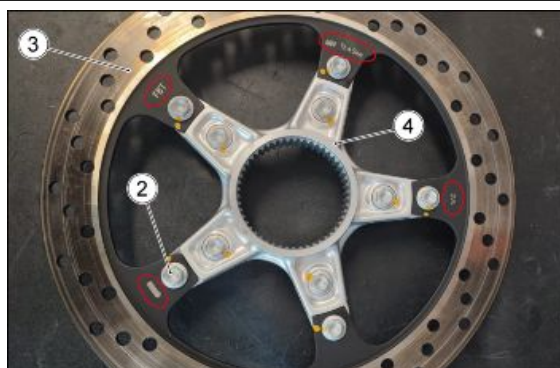

Disc Inspection

REAR

CAUTION

THE BRAKE DISC SHAPE DOES NOT CHANGE THE OPERATING AND MAINTENANCE SPECIFICATIONS OF THE SYSTEM.

- The following operations must be carried out with brake disc fitted on the wheel.
- Check the disc for wear by measuring the minimum thickness with a micrometer in different points. If the minimum thickness, even in a single point of the disc, is less than the minimum value, replace the disc.



Disc thickness minimum value: 4 mm (0.16 in)

Front brake disc

Removal

THE OPERATIONS REFER TO ONE BRAKE DIS, BUT ARE VALID FOR BOTH.

- First remove the front wheel.
- Working on the right side, unscrew the six fixing screws (1) and remove the tone wheel (2) from the wheel.

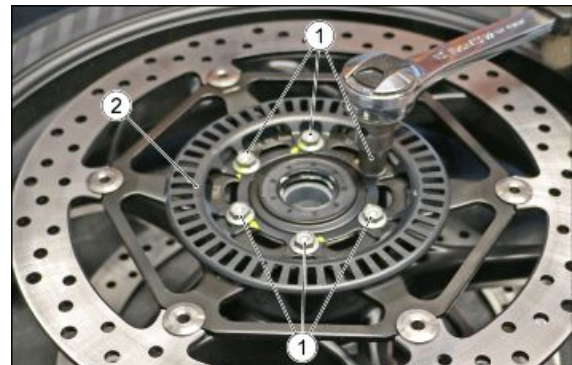

- Remove the right hand front brake disc (3) from the wheel.



Disc Inspection

FRONT

CAUTION

THE FRONT BRAKE DISC SHAPE DOES NOT CHANGE THE OPERATING AND MAINTENANCE SPECIFICATIONS OF THE SYSTEM.

- The following operations must be carried out with the brake discs fitted on the wheel; they refer to a single disc, but are valid for both.
- Check the disc for wear by measuring the minimum thickness with a micrometer in different points. If the minimum thickness, even in a single point of the disc, is less than the minimum value, replace the disc.

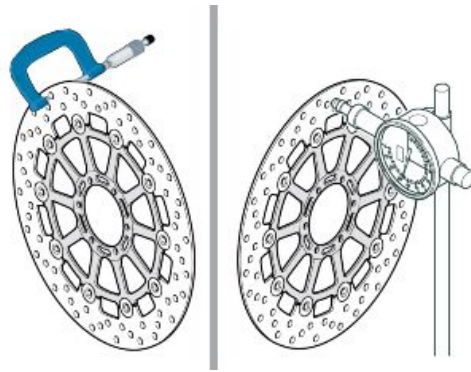

Disc thickness minimum value: 4 mm (0.16 in)

- Using a dial gauge, check that the maximum oscillation of the disc does not exceed the tolerance; otherwise, replace it.

Disc oscillation tolerance: 0.15 mm (0.0059 in), with respect to the wheel centre line.

Installing

THE OPERATIONS REFER TO ONE BRAKE DIS, BUT ARE VALID FOR BOTH.

- Position the brake disc (3) on the wheel hub, making sure that the markings on the brake disc face outwards. Also check the correct direction of rotation, indicated by the arrow stamped on the disc.
- Fit the tone wheel (2) on the brake disc and install the six fixing screws (1).
- Progressively tighten the fixing screws (1) following the A-B-C-D-E-F sequence and bring them to the specified tightening torque.

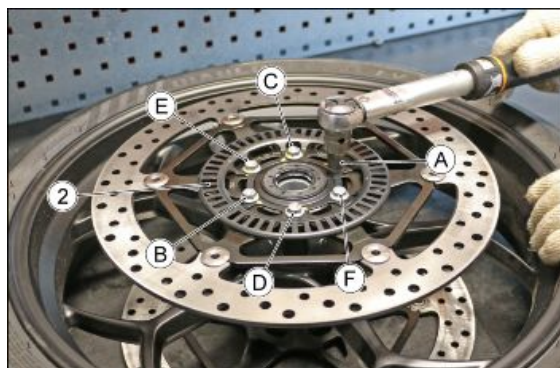

Locking torques (N*m)

Brake disc fixing screw 30 ± 4.5 Nm (22.13 ± 3.32 lb ft)

Front brake pads

Removal



THIS VEHICLE IS FITTED WITH A DOUBLE DISC FRONT BRAKING SYSTEM (RIGHT AND LEFT SIDE).

ALWAYS REPLACE ALL THE PADS FROM BOTH FRONT BRAKE CALLIPERS.

REPLACING THE PADS OF ONLY ONE FRONT CALLIPER MAY JEOPARDISE THE VEHICLE STABILITY AND SAFETY, POSING SERIOUS DANGER FOR PEOPLE, OBJECTS AND THE VEHICLE ITSELF.

CAUTION

THE FOLLOWING OPERATIONS REFER TO A SINGLE CALLIPER, BUT APPLY TO BOTH.

To remove the front brake pads proceed as described:

- Remove the cotter pin (1) from the pin.

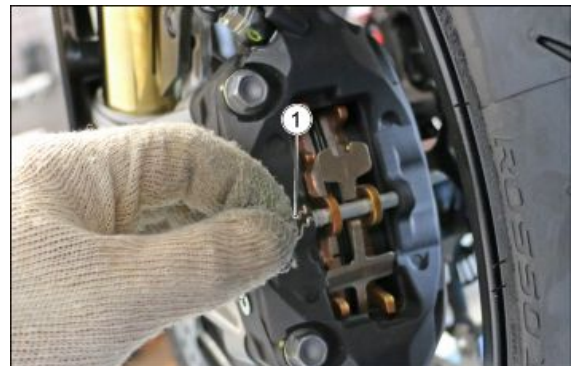

- Unscrew the pin (2) and remove it from the calliper.



- Remove the spring (3) from the brake calliper.



- Remove the external pad (4) from the calliper.



- Remove the internal pad (5) from the calliper.



DO NOT OPERATE THE BRAKE LEVER ONCE THE BRAKE PADS HAVE BEEN REMOVED, AS THIS MAY FORCE THE PISTONS OUT FROM THEIR SEATS AND ALLOW BRAKE FLUID TO ESCAPE.



Installing



THIS VEHICLE IS FITTED WITH A DOUBLE DISC FRONT BRAKING SYSTEM (RIGHT AND LEFT SIDE).

ALWAYS REPLACE ALL THE PADS FROM BOTH FRONT BRAKE CALLIPERS.

REPLACING THE PADS OF ONLY ONE FRONT CALLIPER MAY JEOPARDISE THE VEHICLE STABILITY AND SAFETY, POSING SERIOUS DANGER FOR PEOPLE, OBJECTS AND THE VEHICLE ITSELF.

CAUTION

THE FOLLOWING OPERATIONS REFER TO A SINGLE CALLIPER, BUT APPLY TO BOTH.

- Fit the internal pad (5) in the calliper, making sure that the support arm is facing the lower part.



- Install the external pad (4) in the caliper, making sure that the support arm is facing the upper part.



- Install the spring (3) in the caliper.



- Insert the fixing pin (2) in the caliper, ensuring that it passes over the spring and that it is correctly inserted pad bushes.
- Once correctly inserted, tighten it firmly.



- Insert the cotter pin (1) on the pin.
- When installation is complete, press the brake lever several times to release the pistons from the caliper and bring the pads into position.

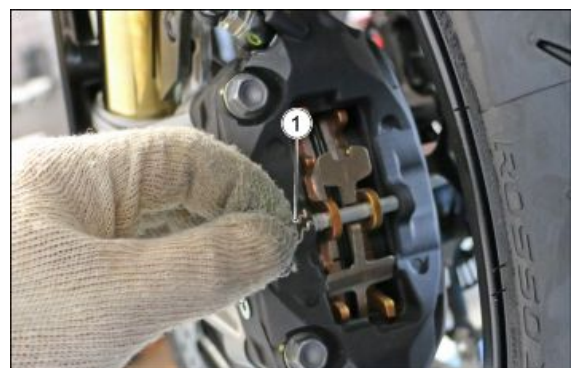

Rear brake pads

Removal

- Press the brake calliper, from the outside, to retract the piston.



- Remove the cotter pins (1) from the pin.



Remove the pin (2) from the brake calliper.



- Remove the external brake pad (3) from the calliper.



- Remove the internal brake pad (4) from the calliper.



Installing

- Insert the internal pad (4) in the calliper and lock it in position by inserting the pin (2) in the relative eyelet of the pad.

CAUTION



ALWAYS REPLACE BOTH PADS AND MAKE SURE THEY ARE CORRECTLY POSITIONED INSIDE THE CALLIPER.



- Insert the external pad (3) in the brake calliper and insert completely the pin (2), bringing it to the end with the brake calliper.

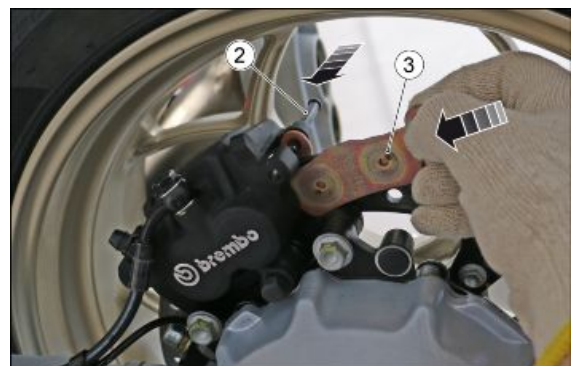

- Insert the two cotter pins (1) on the pin.
- When installation is complete, press the brake lever several times to release the pistons from the calliper and bring the pads into position.



MAKE SURE THAT THE FRONT PART OF THE PADS IS INSERTED CORRECTLY IN ITS SEAT ON THE BRAKE CALLIPER SUPPORT.



Bleeding the braking system

PREPARATION OF THE VEHICLE

- Place the vehicle on a flat surface and in vertical position.
- Protect the areas around the front and/or rear brake fluid tanks, avoiding under any circumstances that the fluid comes into contact with the bodywork and/or painted parts of the vehicle.
- The use of a pneumatic bleeding device facilitates these operations, especially when, in addition to just bleeding, the brake fluid also needs to be changed.



Front

TRADITIONAL BLEEDING SYSTEM

WARNING

BLEED BOTH FRONT BRAKE CALLIPERS

Any air trapped in the hydraulic circuit acts as a cushion, absorbing much of the pressure applied by the brake pump and minimising the braking power of the calliper.

The presence of air is signalled by the "sponginess" of the brake and by poor braking.



CONSIDERING THE DANGER FOR VEHICLE AND RIDER, IT IS STRICTLY NECESSARY, AFTER REFITTING THE BRAKE CALLIPERS AND RESTORING THE BREAKING SYSTEM TO ITS REGULAR USE CONDITIONS, SO THAT THE HYDRAULIC CIRCUIT IS AIR PURGED.

NOTE

THE FOLLOWING OPERATIONS REFER TO ONE FRONT BRAKE CALLIPER ONLY, BUT ARE VALID FOR BOTH. THE VEHICLE MUST BE ON LEVEL GROUND TO BE BLED. WHILE PURGING THE HYDRAULIC SYSTEM, FILL THE RESERVOIR WITH THE NECESSARY QUANTITY OF BRAKE FLUID. CHECK THAT, DURING THE OPERATION, THERE IS ALWAYS BRAKE FLUID IN THE RESERVOIR.

- Unscrew the two screws (1) and remove the cap (2).



- Remove the protective rubber (3).



- Refill the tank with brake fluid.

CAUTION

DURING BLEEDING OPERATIONS, CONSTANTLY TOP UP THE TANK SO THAT IT NEVER RUNS EMPTY. OTHERWISE AIR WILL ENTER THE CIRCUIT AND THE BLEEDING OPERATION WILL HAVE TO BE STARTED ALL OVER AGAIN.



- Remove the rubber cap from the bleed valve.

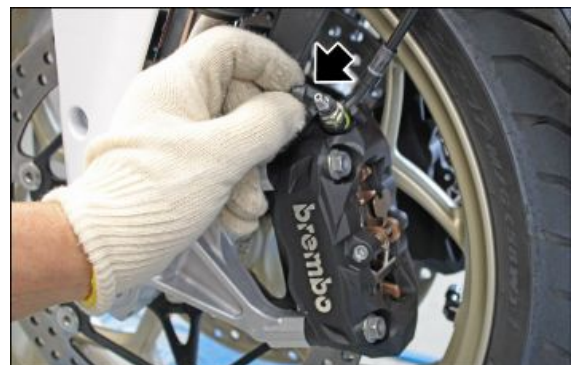

- Insert an 8 mm spanner on the bleeding valve and attach a rubber hose (4) to the valve connection.
- Connect the other end of the rubber hose to a suitably sized container.



- FULLY press and release the front brake lever quickly for several times.
- After four / five complete cycles, hold the front brake lever fully depressed.



- Keeping the front brake lever depressed, open the brake calliper bleeding valve. This will drain the brake fluid inside the container.
- Close the bleeding valve BEFORE releasing the front brake lever.
- Repeat the "braking" and bleeding cycles until the fluid coming out of the calliper is free of air bubbles.

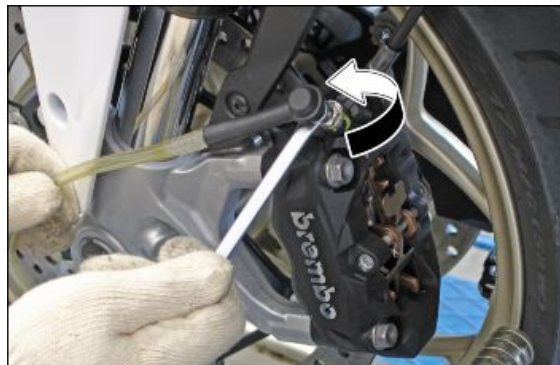

- Test the lever stroke and ensure that the pressure does not feel "spongy". In this case, air is still present in the circuit, which must be removed by repeating the above steps.
- After completing operations, tighten the bleeding valve and remove the rubber hose and spanner.
- Replace the rubber cap.

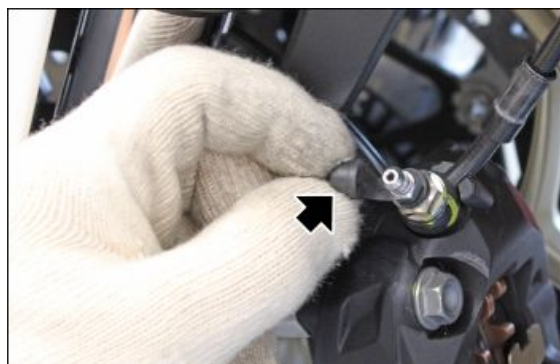

- Top up the tank with brake fluid to the correct level.
- Replace the protective rubber, the tank cap and tighten the two fixing screws.



BLEEDING SYSTEM WITH DIAGNOSTIC INSTRUMENT

If the brake lever still feels "spongy" after completing all checks, it is necessary to bleed the brakes using this type of procedure.

- With the diagnostic tool properly connected, select the function "FRONT BLEEDING" in the section "SETTINGS".
- The pump starts running.
- While the pump is performing a rotation cycle, operate and release the front brake lever until the message diagnostic tool cycle completion is received.
- This procedure allows the air to circulate and accumulate.
- Once the procedure with diagnostic tool is finished, perform again the REGULAR PURGING to remove the air from the system completely.

Rear

TRADITIONAL BLEEDING SYSTEM

Any air trapped in the hydraulic circuit acts as a cushion, absorbing much of the pressure applied by the brake pump and minimising the braking power of the calliper.

The presence of air is signalled by the "sponginess" of the brake and by poor braking.



CONSIDERING THE DANGER FOR VEHICLE AND RIDER, IT IS STRICTLY NECESSARY, AFTER REFITTING THE BRAKE CALLIPER TO RESTORE THE BRAKING SYSTEM TO ITS REGULAR USE CONDITIONS, SO THAT THE HYDRAULIC CIRCUIT IS AIR PURGED.

NOTE

THE VEHICLE MUST BE ON LEVEL GROUND TO BE BLED. WHILE PURGING THE HYDRAULIC SYSTEM, FILL THE RESERVOIR WITH THE NECESSARY QUANTITY OF BRAKE FLUID. CHECK THAT, DURING THE OPERATION, THERE IS ALWAYS BRAKE FLUID IN THE RESERVOIR.

Rear brake circuit

- Unscrew the cap (1) of the rear brake fluid tank.



- Remove the protective rubber (2).



- Refill the tank with brake fluid.

CAUTION

DURING BLEEDING OPERATIONS, CONSTANTLY TOP UP THE TANK SO THAT IT NEVER RUNS EMPTY. OTHERWISE AIR WILL ENTER THE CIRCUIT AND THE BLEEDING OPERATION WILL HAVE TO BE STARTED ALL OVER AGAIN.



- Remove the rubber cap from the bleed valve.



- Insert an 8 mm spanner on the bleeding valve and attach a rubber hose (3) to the valve connection.
- Connect the other end of the rubber hose to a suitably sized container.

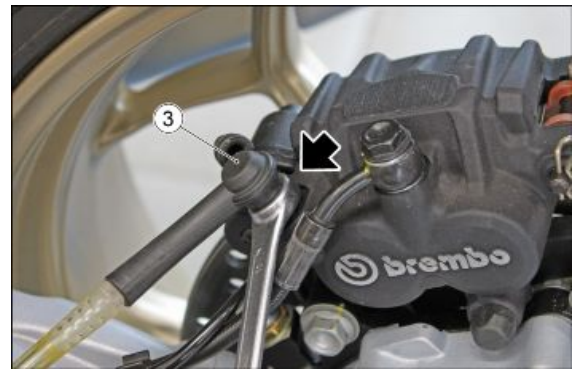

- FULLY press and release the rear brake pedal quickly for several times.
- After four / five complete cycles, hold the rear brake pedal fully depressed.



- Holding the rear brake pedal depressed, open the brake calliper bleeding valve. This will drain the brake fluid inside the container.
- Close the bleeding valve BEFORE releasing the rear brake pedal.
- Repeat the "braking" and bleeding cycles until the fluid coming out of the calliper is free of air bubbles.

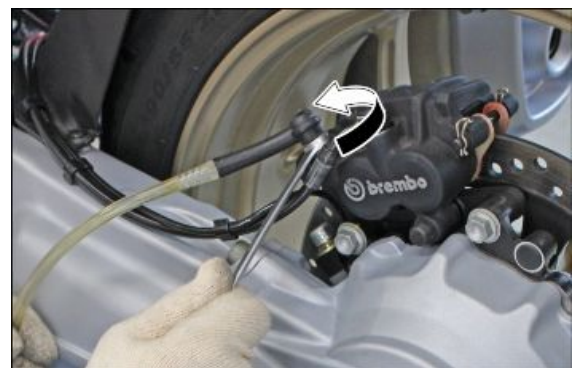

- Test the pedal stroke and ensure that the pressure does not feel "spongy". In this case, air is still present in the circuit, which must be removed by repeating the above steps.
- After completing operations, tighten the bleeding valve and remove the rubber hose and spanner.
- Replace the rubber cap.



- Top up the tank with brake fluid to the correct level.
- Replace the protective rubber and screw the tank cap back on.



BLEEDING SYSTEM WITH DIAGNOSTIC INSTRUMENT

If the brake lever still feels "spongy" after completing all checks, it is necessary to bleed the brakes using this type of procedure.

- With the diagnostic tool properly connected, select the function "REAR BLEEDING" in the section "SETTINGS".
- The pump starts running.
- While the pump is performing a rotation cycle, operate and release the rear brake pedal until the message of diagnostic tool cycle completion is received.
- This procedure allows the air to circulate and accumulate.
- Once the procedure with diagnostic tool is finished, perform again the REGULAR PURGING to remove the air from the system completely.

Changing the brake fluid

WARNING



WHEN CHANGING BRAKE FLUID, USE A PNEUMATIC PUMP FOR BLEEDING BRAKE SYSTEMS. THE BRAKE FLUID MUST ALWAYS BE REPLACED IN EACH BRAKE CALLIPER OF THE VEHICLE AND IN BOTH CIRCUITS.

- Place the vehicle on a flat surface and in vertical position.
- Protect the areas around the front and rear brake fluid tanks, avoiding under any circumstances that the fluid comes into contact with the bodywork and/or painted parts of the vehicle.





Front brake circuit

NOTE



THE OPERATIONS CONCERNING THE FRONT BRAKE CIRCUIT REFER TO ONLY ONE BRAKE CALLIPER, BUT ARE VALID AND MUST BE CARRIED OUT ON BOTH.

- Unscrew the two screws (1) and remove the cap (2).



- Remove the protective rubber (3).



- Refill the tank with brake fluid.



- Remove the rubber cap from the bleed valve.



- Insert an 8 mm spanner on the bleed valve and attach the rubber hose (3), from the pneumatic pump, to the valve connection.

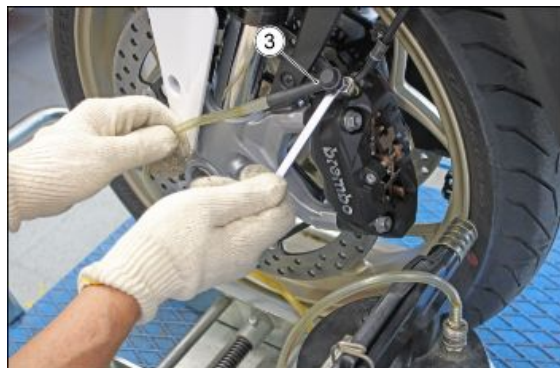

- Operate the pneumatic pump for bleeding and open the bleeding valve of the brake calliper.
- Repeat the steps until the fluid coming out of the brake calliper is light-coloured; then close the bleed valve and stop the pneumatic pump.
- Once the pump is stopped, remove the rubber hose and spanner from the brake calliper.

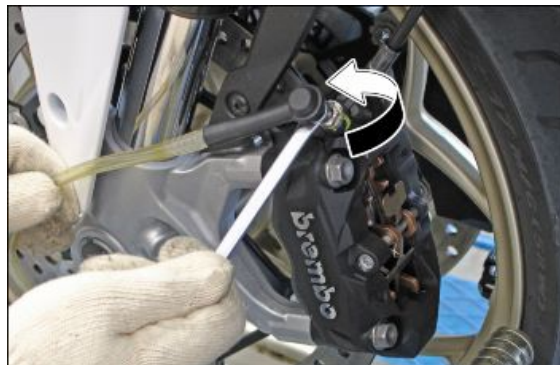

CAUTION

CONSTANTLY CHECK THAT THE LIQUID INSIDE THE TANK NEVER FALLS BELOW THE MINIMUM LEVEL. TOP UP WHEN NECESSARY, USING THE RECOMMENDED PRODUCT.

Recommended products

DOT 4 brake fluid Synthetic brake fluid.

SAE J 1703; FMVSS 116; ISO 4925; CUNA NC 956 DOT4

- Check the brake lever stroke and that the pressure does not feel "spongy". Otherwise, it means that there is air in the circuit and it must be bled.



- Once the operations are finished, replace the rubber cap on the bleeding valve.



- Top up the tank with brake fluid to the correct level.
- Replace the protective rubber and the tank cap and tighten the fixing screws.



Rear brake circuit

- Unscrew the cap (1) of the rear brake fluid tank.



- Remove the protective rubber (2).



- Refill the tank with brake fluid.



- Remove the rubber cap from the bleed valve.

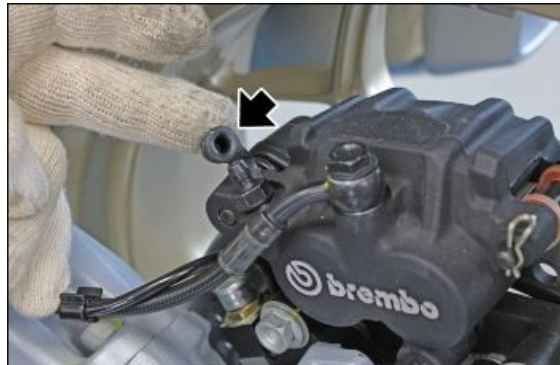

- Insert an 8 mm spanner on the bleed valve and attach the rubber hose (3), from the pneumatic pump, to the valve connection.



- Operate the pneumatic pump for bleeding and open the bleeding valve of the brake calliper.
- Repeat the steps until the fluid coming out of the brake calliper is light-coloured; then close the bleed valve and stop the pneumatic pump.
- Once the pump is stopped, remove the rubber hose and spanner from the brake calliper.

**CAUTION**

CONSTANTLY CHECK THAT THE LIQUID INSIDE THE TANK NEVER FALLS BELOW THE MINIMUM LEVEL. TOP UP WHEN NECESSARY, USING THE RECOMMENDED PRODUCT.

Recommended products

DOT 4 brake fluid Synthetic brake fluid.

SAE J 1703; FMVSS 116; ISO 4925; CUNA NC 956 DOT4

- Check the brake pedal stroke and that the pressure does not feel "spongy". Otherwise, it means that there is air in the circuit and it must be bled.



- Once the operations are finished, replace the rubber cap on the bleeding valve.



- Top up the tank with brake fluid to the correct level.
- Replace the protective rubber and screw the tank cap back on.



Front brake pump

Removal

- Place a container under the pump to collect the brake fluid.
- Remove the union screw from the pipe.



- Retrieve the two sealing washers.



DURING REFITTING, USE NEW SEALING WASHERS.

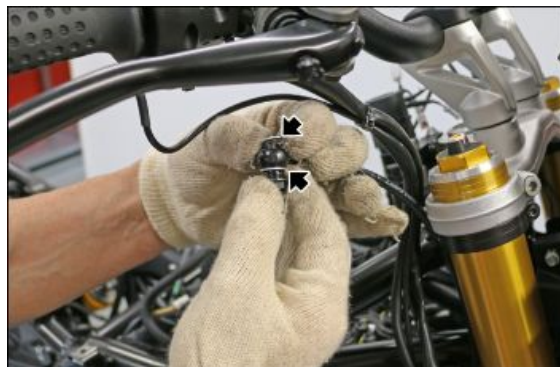

- Remove the two fixing screws from the front brake master cylinder.

During refitting, tighten the screws to the prescribed torque.

Locking torques (N*m)

Screw fastening front brake master cylinder 10 Nm (7.38 lbf ft)



- Remove the U-bolt and front brake master cylinder from the vehicle.



Rear brake pump

Rimozione

- Place a container under the pump to collect the brake fluid.
- Remove the union screw (1) and retrieve the sealing washers (2).



DURING REFITTING, USE NEW SEALING WASHERS.

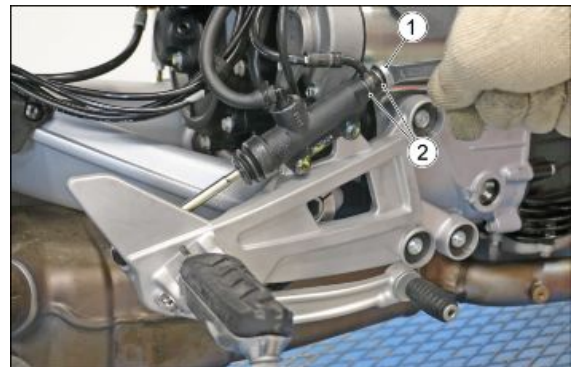

- Remove the fixing screw (3) of the rear brake fluid tank.

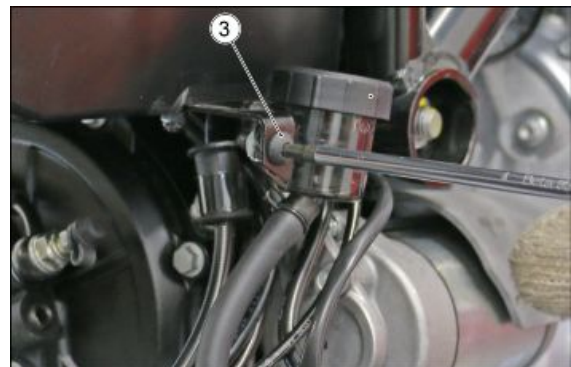

- Remove the two screws (4) fixing the brake pump to the right-hand rider foot-rest mounting plate.



- Remove the rear brake pump from the vehicle.

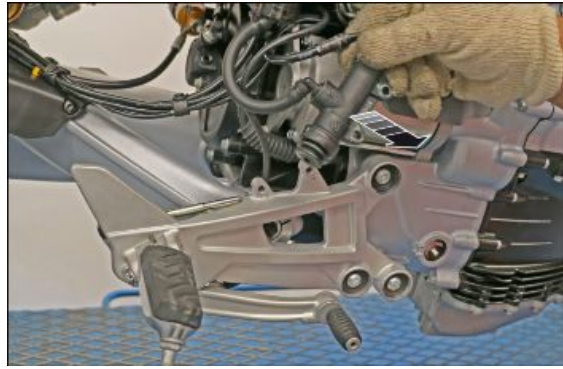

REAR BRAKE FLUID RESERVOIR REMOVAL

- Place a container under the pump to collect the brake fluid.
- Remove the metal clamp (1) and remove the rubber pipe (2) from the tank (3).
- Remove the fixing screw (4) and remove the tank (3) from the vehicle.

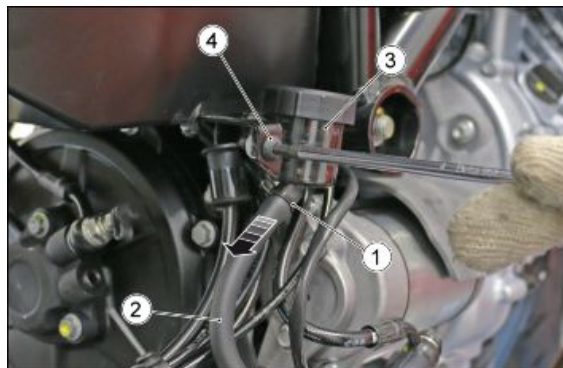

Brake system lines

Removal

FRONT BRAKE PUMP PIPE - MODULATOR

- Open the upper rubber clamp (1) and release the brake pipe from the pipe grommet on the right fork stanchion.



- Remove the two pipe grommets from the frame.

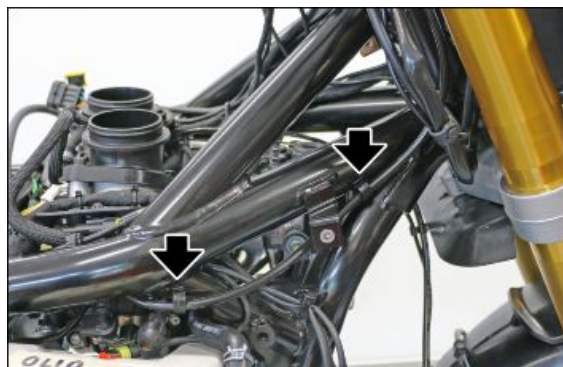

- Unscrew the front brake pump connector.



- Remove the connector from the front brake pump and collect the sealing washers.



DURING REFITTING, USE NEW SEALING WASHERS.

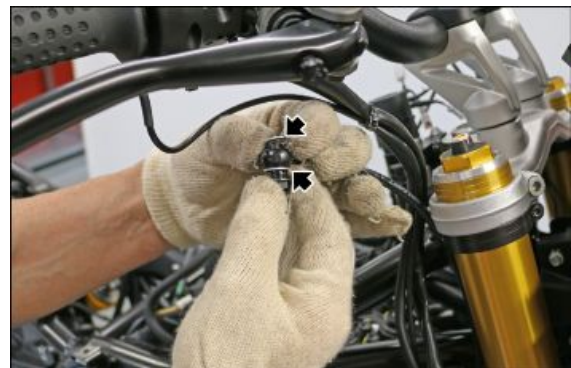

- Unscrew the connector from the modulator.



- Remove the connector from the modulator and collect the sealing washers.



DURING REFITTING, USE NEW SEALING WASHERS.

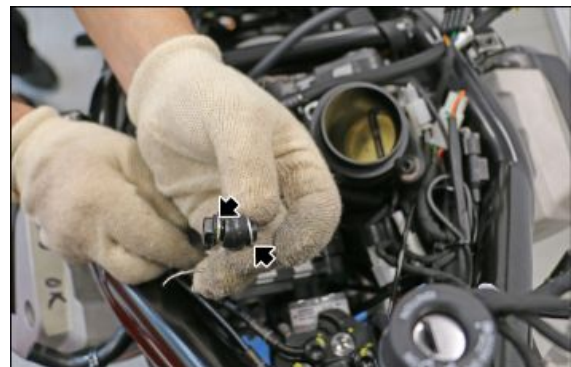

- Remove the brake pipe from the vehicle as shown in the figure.



MODULATOR PIPE / RIGHT FRONT BRAKE CALLIPER

- Remove the four pipe grommets from the front brake pipe.

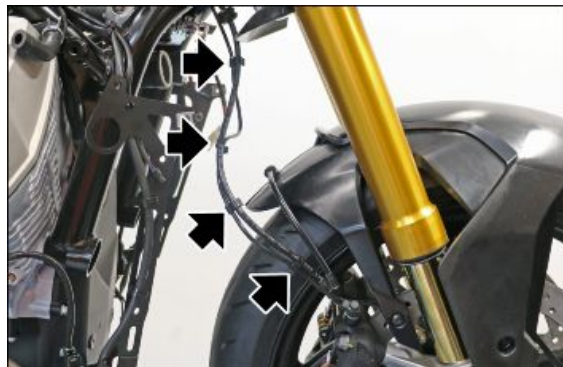

- Unscrew the connector from the modulator.



- Remove the connector from the modulator and collect the sealing washers.



DURING REFITTING, USE NEW SEALING WASHERS.

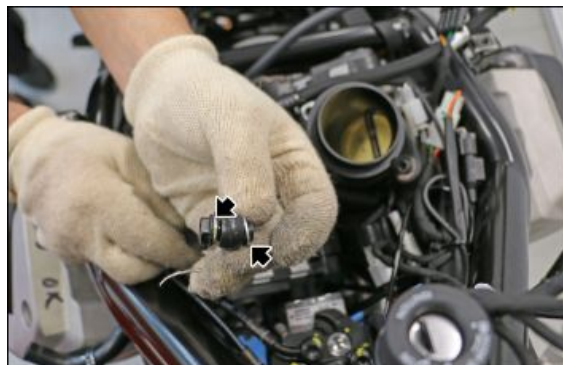

- Unscrew the connector from the brake calliper.

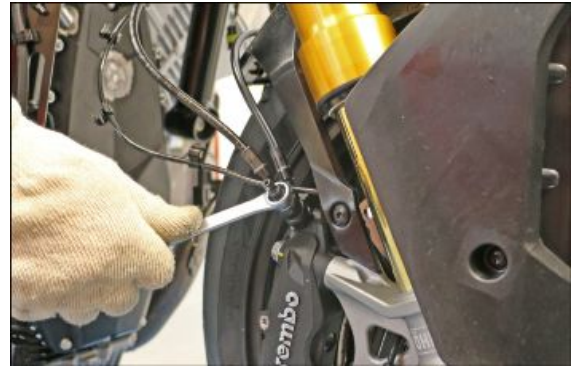

- Remove the connector from the front brake calliper and collect the three sealing washers.

NOTE

DURING REASSEMBLY, THE PIPE FROM THE MODULATOR (2) GOES OVER THE CALLIPER COMMUNICATING PIPE (3).



DURING REFITTING, USE NEW SEALING WASHERS.

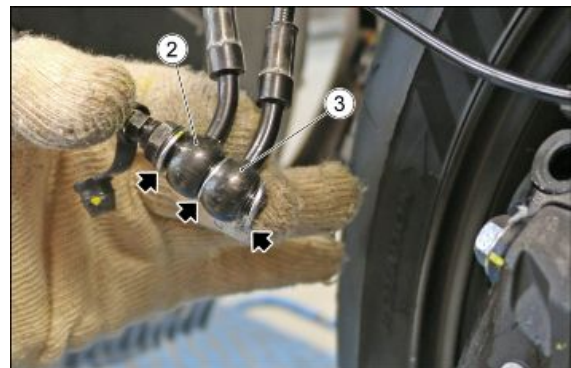

- Remove the brake pipe from the vehicle as shown in the figure.



FRONT BRAKE CALLIPERS CONNECTING PIPE

- Remove the hose guide (1) from the front mudguard.

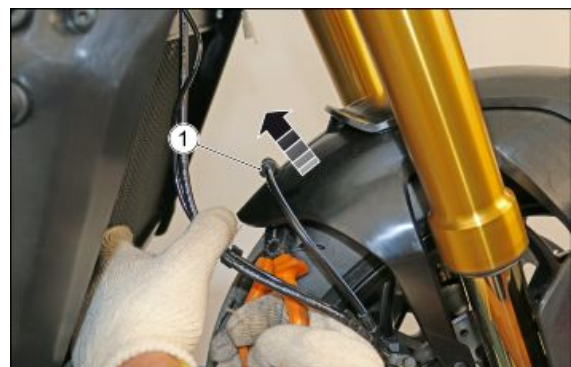

- Unscrew the connector from the brake calliper.



- Remove the connector from the front brake calliper and collect the three sealing washers.

NOTE

DURING REASSEMBLY, THE PIPE FROM THE MODULATOR (2) GOES OVER THE CALLIPER COMMUNICATING PIPE (3).



DURING REFITTING, USE NEW SEALING WASHERS.

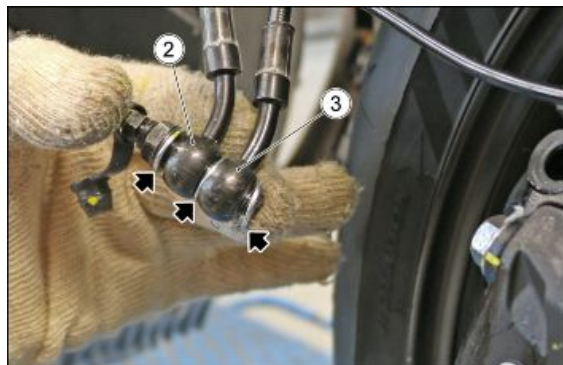

- Unscrew the connector from the front left brake calliper.



- Remove the connector from the front left brake calliper and collect the three sealing washers.



DURING REFITTING, USE NEW SEALING WASHERS.

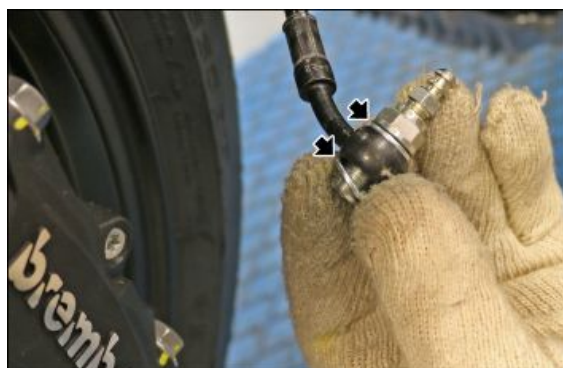

- Remove from the vehicle the front brake calliper connection pipe, as shown in the figure



REAR BRAKE PUMP PIPE - MODULATOR

- Unscrew the connector of the rear brake pump.



- Remove the connector of the rear brake pump and retrieve the two sealing washers.



DURING REFITTING, USE NEW SEALING WASHERS.



- Unscrew the connector from the modulator.



- Remove the connector from the modulator and collect the sealing washers.



DURING REFITTING, USE NEW SEALING WASHERS.

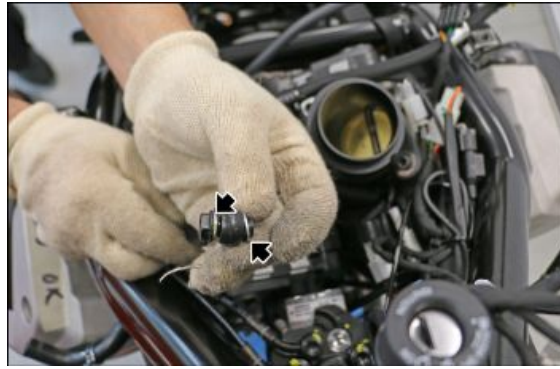

- Release the rigid pipe from the lower clip (1) used to fasten it to the frame.



- Release the rigid pipe from the upper clip (2) used to fasten it to the frame, located next to the throttle bodies.



- Remove the brake pipe from the vehicle, pulling it upward, as shown in the figure.



MODULATOR PIPE - REAR BRAKE CALLIPER

- Unscrew the modulator connector.



- Remove the connector from the modulator and collect the sealing washers.



DURING REFITTING, USE NEW SEALING WASHERS.

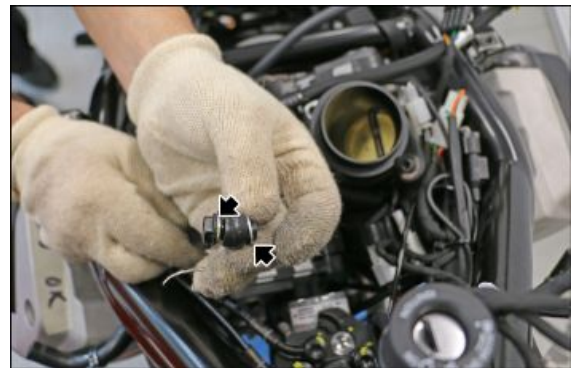

- Unscrew the rear brake calliper connector.



- Remove the coupling from the rear brake calliper and collect the sealing washers.



DURING REFITTING, USE NEW SEALING WASHERS.



- Remove the screw fixing the pipe grommet to the clutch housing.

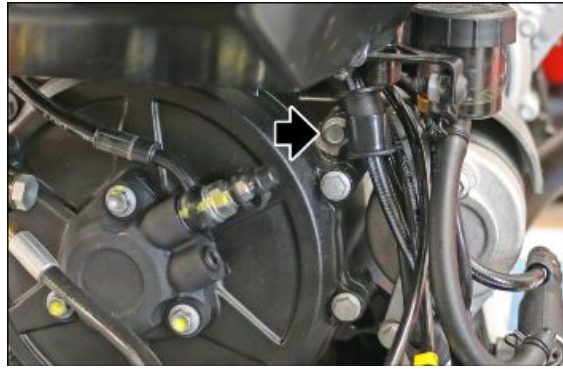

- Release the rigid pipe from the lower clip (1) used to fasten it to the frame.



- Release the rigid pipe from the upper clip (2) used to fasten it to the frame.



- Cut the plastic clamp (3) and release the hose guides (4) from the rear brake pipe, leaving them fastened to the ABS sensor cable.

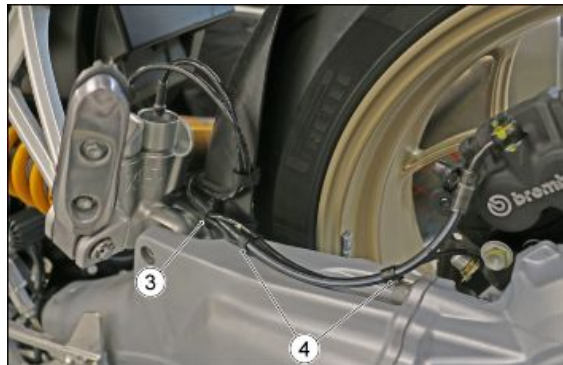

- Remove the brake pipe from the swing-arm, passing it between the shock absorber and the mudguard, as shown in the figure.

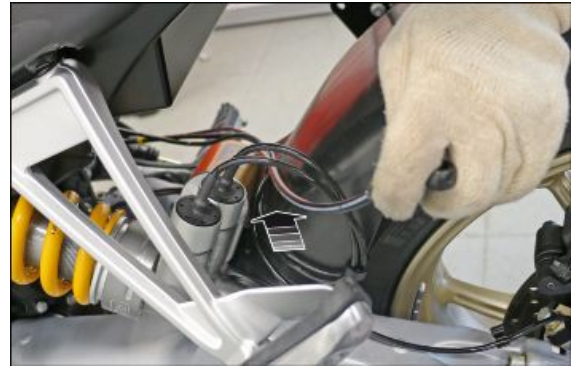

- Remove the brake pipe from the vehicle, pulling it upward, as shown in the figure.



INDEX OF TOPICS

CLUTCH SYSTEM

CLU SYS

Removing the clutch master cylinder

CLUTCH PIPE

REMOVAL

- Drain the fluid completely from the clutch control circuit.
- Unscrew the coupling of the clutch master cylinder.



- Remove the connector from the clutch master cylinder and collect the sealing washers.



DURING REFITTING, USE NEW SEALING WASHERS.

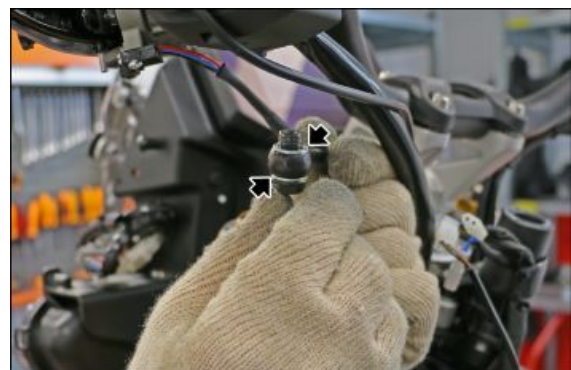

- Unscrew the control cylinder connector.

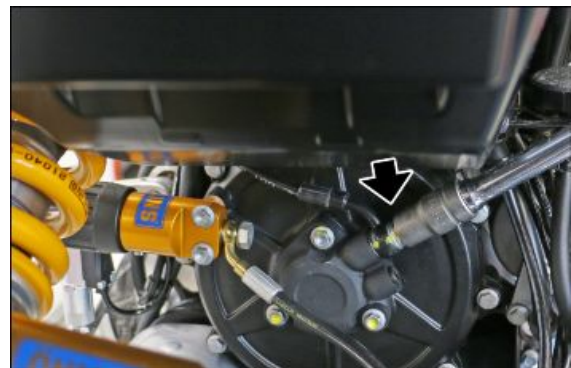

- Remove the connector from the clutch control cylinder and collect the sealing washers.



DURING REFITTING, USE NEW SEALING WASHERS.

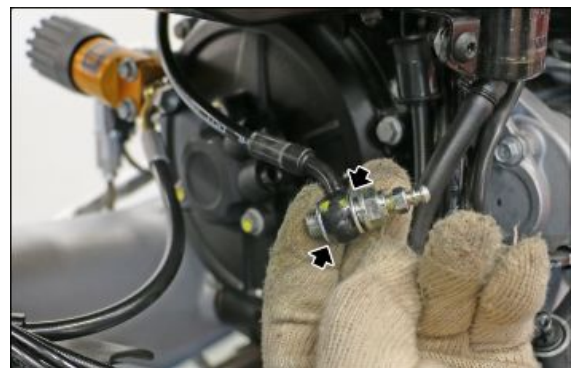

- Remove the two pipe grommets from the left beam of the frame.

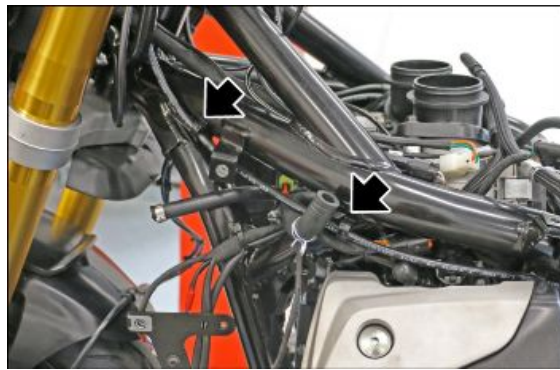

- Pass the clutch pipe between the engine and the frame, as illustrated in the figure.



- Remove the clutch pipe from the vehicle, pulling it upward, as shown in the figure.



During refitting, make sure you pass the clutch pipe between the frame and the conduit of the electric system, as shown in the figure.



FITTING

To refit, follow the removal procedures in reverse, bleeding the system after assembly is complete.

Removing the clutch slave cylinder

- Remove the union screw (1) and retrieve the sealing washers (2).



DURING REFITTING, USE NEW SEALING WASHERS.

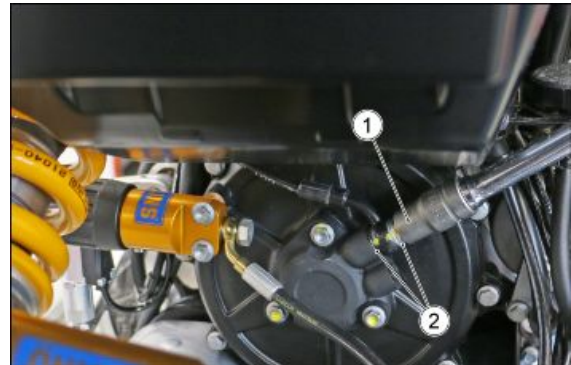

- Remove the two fixing screws (3) of the rear shock absorber preload adjuster.

During refitting, tighten the fixing screws to the prescribed torque.

Locking torques (N*m)

Preload adjuster fixing screw 10 ± 2 Nm (7.38 ± 1.48 lb ft)



- Remove the three fixing screws (4).

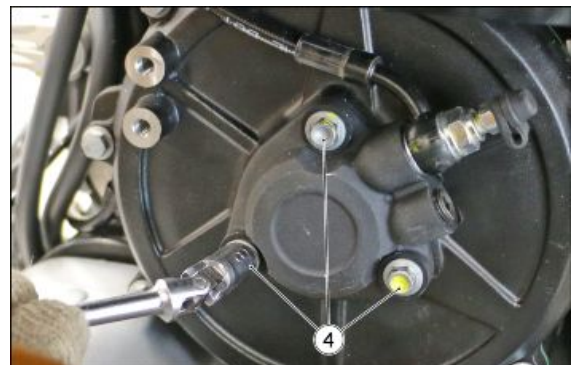

- Remove the clutch cylinder (5) from the clutch housing.



AFTER REFITTING, BLEED THE HYDRAULIC CIRCUIT OF THE CLUTCH.

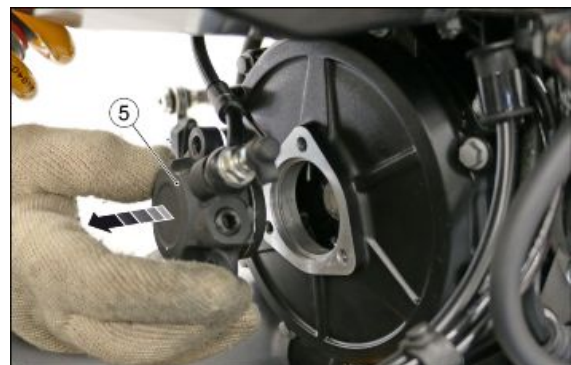

INDEX OF TOPICS

COOLING SYSTEM

COOL SYS

Coolant replacement



PERFORM THE INDICATED OPERATIONS WHEN THE ENGINE IS COLD.

- Place the vehicle upright and prepare a container of adequate size under the oil sump.



- Remove the filler plug of the expansion tank.



- Remove the filler plug the radiator.



- Place a container of adequate dimensions under the radiator.
- Remove the radiator drain plug and allow the fluid from the radiator to drain into the container.

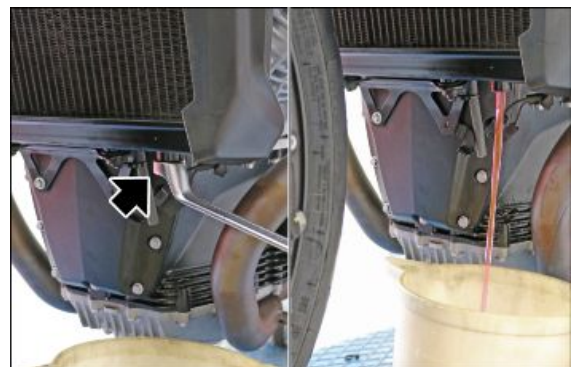

- Remove the pipe from the "indicator light" fitting on the water pump.



- Remove the bleed screw and allow the coolant to drain completely from the water pump.



Cooling circuit filling

- Insert the bleed screw on the water pump using a NEW sealing washer and tighten it to the specified torque.



- Refit the pipe on the "indicator light" fitting of the water pump.



- Insert the drain screw of the radiator with a NEW sealing washer and tighten it to the specified torque.



- Refill the radiator with the Anti-freeze liquid specified.

**NOTE**

Refill the radiator up to the lower edge of the filler plug.



- Install and tighten the radiator cap properly.

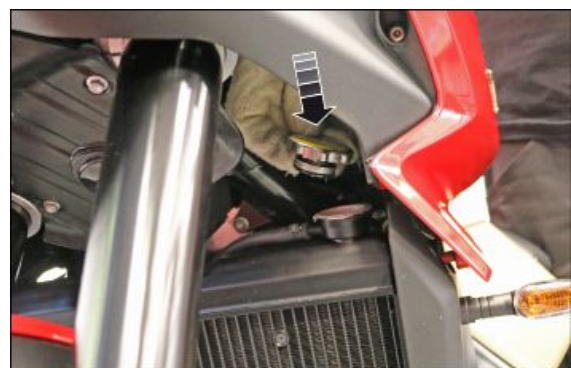

- Fill the expansion tank with the specified anti-freeze liquid up to the MAX mark.

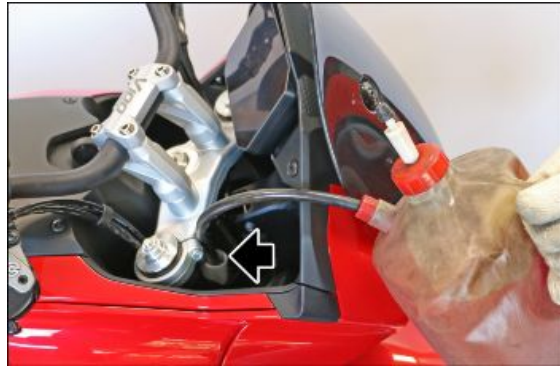

- Fit the expansion tank cap.
- Start the engine and let it idle until the radiator fan starts.

NOTE

THE COOLING SYSTEM OF V100 IS SELF-BLEEDING. ONCE THE RADIATOR AND EXPANSION TANK ARE FILLED CORRECTLY AND THE ENGINE IS RUNNING UNTIL THE RADIATOR FAN COMES STARTS, NO FURTHER ACTION IS REQUIRED TO PURGE THE CIRCUIT.

**Characteristic****Radiator cooling fan start-up**

101° C

Radiator cooling fan shut-off

98° C

- Switch off the engine and top up the coolant level in the expansion tank.

Removing the radiator

PERFORM THE INDICATED OPERATIONS WHEN THE ENGINE IS COLD.

- First remove the side fairings.
- Remove the screw fixing the horn.



- Disconnect the connectors and remove the horn from the vehicle.

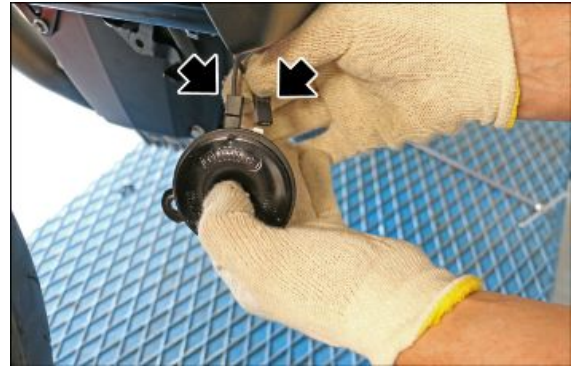

- Remove the cap from the radiator.



- Place a container under the radiator, remove the drain plug and completely drain the coolant from the radiator.



- Unscrew the two upper fixing screws of the radiator side fairing.



- Release the fairing from the relative re-tainer to the radiator, sliding it downward.



- Disconnect the turn indicator connector and remove the side fairing from the vehicle.
- Repeat the operations for the fairing of the side opposite side.



- Unscrew the two fixing screws (1) of the fairing support (2) and remove the support from the radiator, leaving it fastened to the wiring harnesses.
- Repeat the operations described above for the opposite side.



- Remove the radiator upper fixing screw.

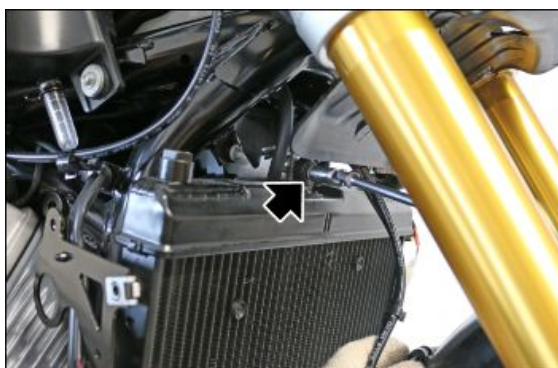

- Remove the second lower screw fastening the radiator. (The first fastens the horn and has been removed previously.)

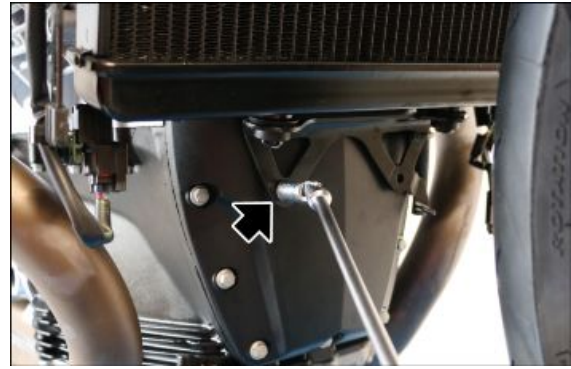

- Open the metal clamp (3) and remove the pipe that connects the radiator to the expansion tank.



DURING REFITTING, USE A NEW CLAMP.

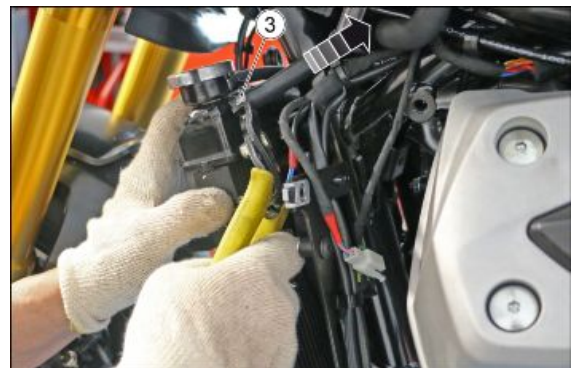

- Open the spring clamp (4) and remove the breather pipe from the radiator.

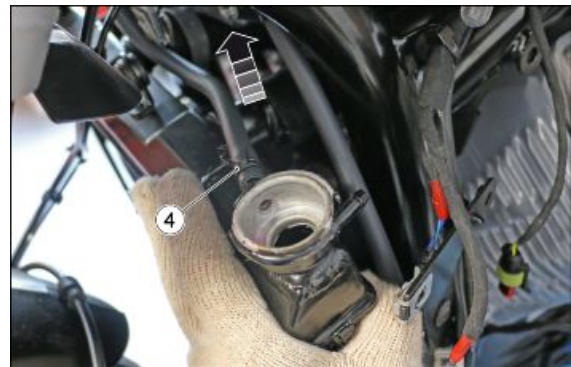

- Loosen the metal clamp (5) and remove the left pipe from the radiator.

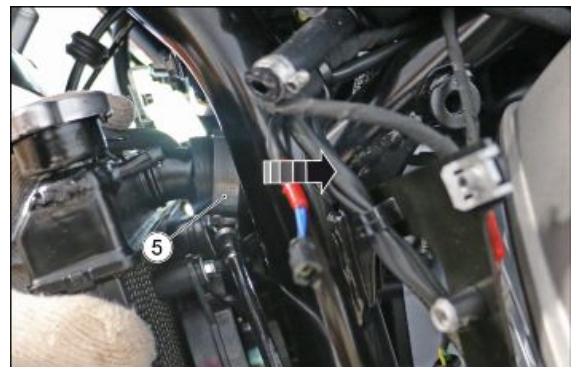

- Disconnect the electrical fan connector (6) and pull the wiring harness out of the vehicle.



- Loosen the metal clamp (7) and remove the right pipe from the radiator.



- Remove the radiator from the vehicle, sliding it downward and by extracting it laterally.

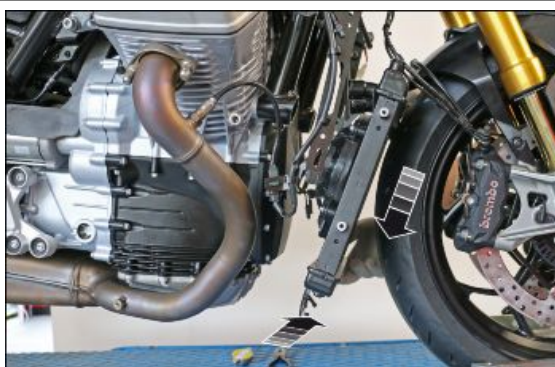

Removing the expansion tank



PERFORM THE INDICATED OPERATIONS WHEN THE ENGINE IS COLD.

- First remove the side fairings and the fuel tank.
- Place a container under the radiator, remove the drain plug and drain the coolant until the expansion tank is empty.



NOTE

TO REMOVE THE EXPANSION TANK IS NOT NECESSARY TO REMOVE THE RADIATOR.

- Open the metal clamp and remove the pipe that connects the radiator to the expansion tank.



DURING REFITTING, USE A NEW CLAMP.

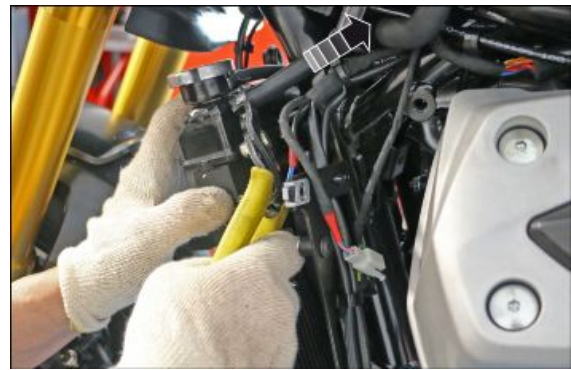

- Remove the fixing screw.

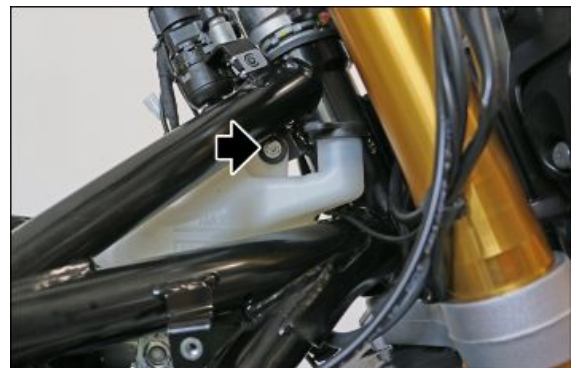

- Lift the rear part of the expansion tank to remove it from its housing on the ABS modulator.



- Pass the load cap between the frame beams.



- Remove the expansion tank from the vehicle.



Thermostatic valve

Removing

- Preventively remove:
 1. The top fairing;
 2. The side fairings;
 3. The fuel tank;
 4. The air filter housing;
 5. The throttle bodies.
- Open the filler cap and remove the radiator bleed screw (shown in the figure), so that the coolant is completely drained from the circuit.
- Disconnect the coolant temperature sensor connector (1).

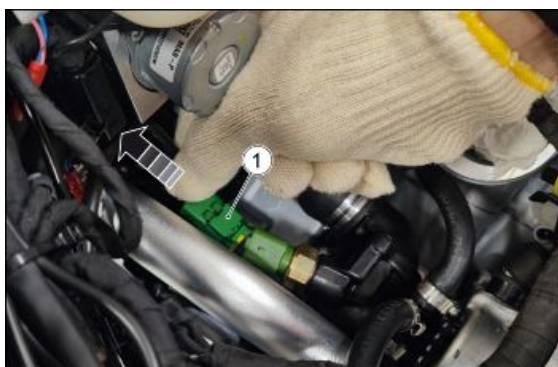

- Remove the front fixing screw (2) and retrieve the corresponding cup washer.



- Remove the two rear fixing screws (3) and retrieve the relative cup washers.



- Remove the metal clamps (4) from the sleeves connecting the valve to the radiator.



- Disconnect the sleeves (5) from the thermostatic valve.



- Remove the thermostatic valve assembly from the vehicle.



- Remove the plate (6) from the thermostatic valve



- Remove the O-ring (7).



REPLACE THE O RING UPON EACH REMOVAL.



- Remove the three fixing screws (8).



- Remove the fitting (9).



- Remove the thermostatic valve (10) from the valve body.



Installing

- Follow the removal operations but in reverse order; be careful to carry out the tightening of the fixing screws in two different stages:

WARNING



BEFORE PLACING THE THERMOSTATIC VALVE ASSEMBLY, APPLY A THIN LAYER OF THREEBOND TO THE CRANKCASE ALONG THE O-RING MATING SURFACE OF THE THERMOSTATIC VALVE.

Locking torques (N*m)

Pre-tightening 5 ± 1 Nm (3.69 ± 0.74 lbf ft) **Final tightening** 12 ± 1 Nm (8.85 ± 0.74 lbf ft)

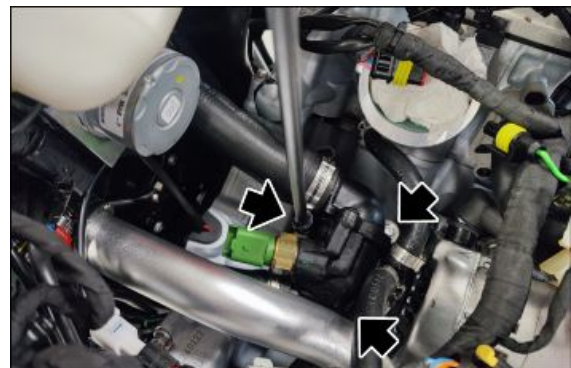

- Install:

1. The throttle bodies;
2. The air filter housing;
3. The fuel tank;
4. The side fairings;
5. The top fairing.

- Fill the cooling circuit following the procedure shown in the chapter: "Coolant change".



INDEX OF TOPICS

BODYWORK

BODYW

Seat

- Rest the vehicle on its stand.
- Insert the key in the saddle lock located on the left-hand side fairing.
- Turn the key clockwise to release the passenger saddle from the lock.



- Lift the front part of the passenger saddle and bring it toward the rear of the vehicle to remove it.
- Now it is possible to access the storage compartment of the vehicle.



- Lift the rear part of the rider saddle, bring it toward the rear of the vehicle to release it from the relative supports and then remove it from the vehicle.
- Once the driver and passenger saddles are removed, you will have access to the vehicle's battery.



Refitting the saddles:

- Move the rider saddle rider in its position, taking care to insert the central fastener and the two front fasteners in the relative seats.



- Insert the rear fastener of the passenger saddle in its support on the vehicle.
- Keeping the saddle in position, press downward the front part to engage the lock.



Instrument panel

REMOVAL

- First remove the front light cluster.
- Remove the LH fixing screws of the adjustable frame windshield.



- Remove the RH fixing screws of the adjustable windshield frame.



- Remove the windshield frame (1) from the instrument support.

NOTE

During refitting, make sure to insert the centring pins (2) in their seats of the instrument panel.

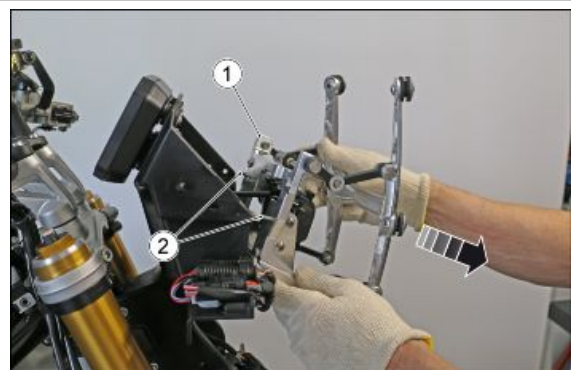

- Release the connector from the instrument support.



- Disconnect the connector of the wiring harness of the adjustable windshield, then remove the frame of the windshield itself from the vehicle.



- Disconnect the connector of the instrument panel wiring harness.



- Unscrew the three fixing screws of the instrument panel and retrieve the relative washers.

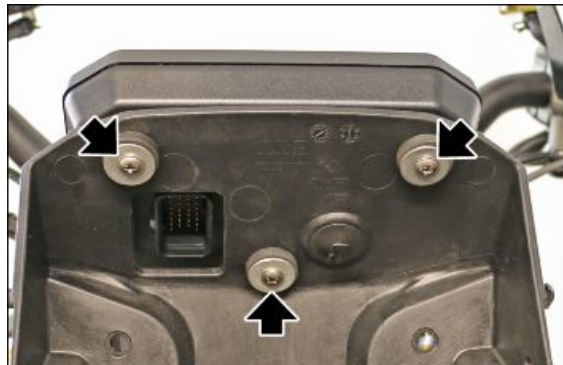

- Remove the instrument panel from the three rubber bushings and remove it from the vehicle.

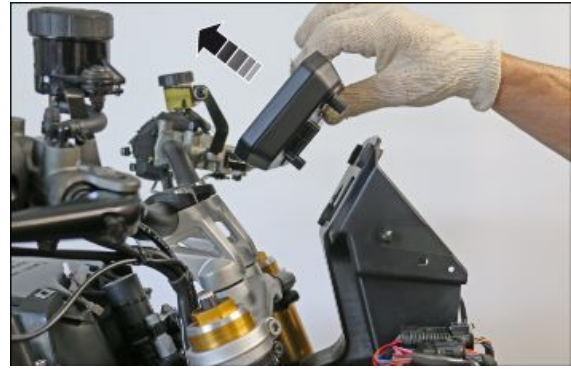

Headlight assy.

FRONTAL SPOILER REMOVAL

- First remove the top fairing and the side fairings.
- Remove the left-hand fixing screw.



- Remove the right-hand fixing screw.



- Remove the spoiler from its housing.

NOTE

During refitting, make sure to insert the pegs (1) in their seats on the vehicle.



- Disconnect the wiring harness connector and remove the spoiler from the vehicle.



FRONT HEADLAMP REMOVAL

- Remove the front spoiler.
- Remove the two upper fixing screws.



- Remove the two lower fixing screws.



- Remove the headlamp from its housing.
- Remove the safety (1) from the connector to release it.



- Disconnect the connector from the headlamp.



- Remove the headlamp from the vehicle.

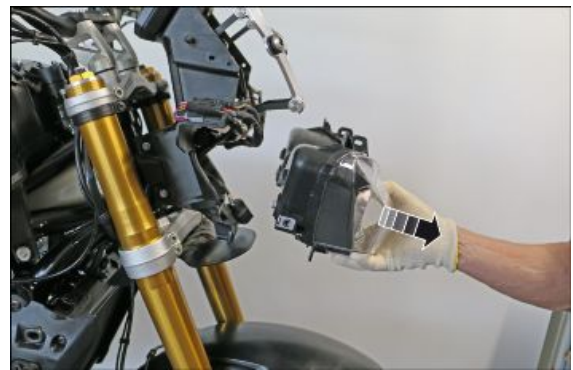

Horn

REMOVAL

- Remove the fixing screw of the horn/lower radiator support.



- Disconnect the two connectors and remove the horn from the vehicle.



Turn indicators

REMOVING FRONT TURN INDICATORS

- First remove the side fairings.
- Unscrew the two upper fixing screws of the radiator side fairing.



- Release the fairing from the relative re-tainer to the radiator, sliding it downward.



- Disconnect the turn indicator connector and remove the side fairing from the vehicle.
- Repeat the operations for the fairing of the side opposite side.



- Remove the nut (1) and the fixing screw (2).



- Release the retaining claw (3) from the inside of the radiator side fairing.



- Remove the turn indicator (4) from the radiator side fairing.
- Repeat the removal operations for the turn indicator on the opposite side.



REAR TURN INDICATORS REMOVAL

- Remove the four fixing screws (1) of the lower cover (2) of the licence plate support.

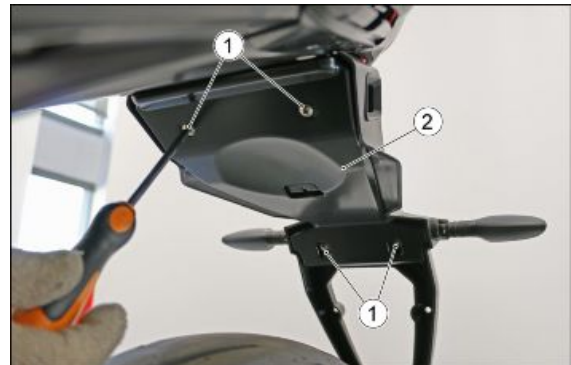

- Remove the cover (2) from the vehicle.



- Disconnect the connectors of the turn indicators.

NOTE

THE RED AND BLUE WIRING HARNESS OF THE VEHICLE IS CONNECTED TO THE RIGHT TURN INDICATOR.



- Remove the fixing screw (3), holding the nut from the rear.



- Remove the turn indicator (4) from the vehicle by sliding the wiring harness inside the licence plate support.
- Repeat the operation for the turn indicator on the opposite side.



Headlight fairing

REMOVAL

- Remove the four screws fixing the windshield and retrieve the relative washers.

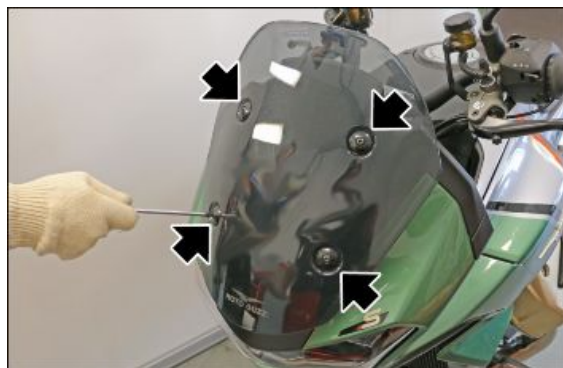

- Remove the windshield from the vehicle.

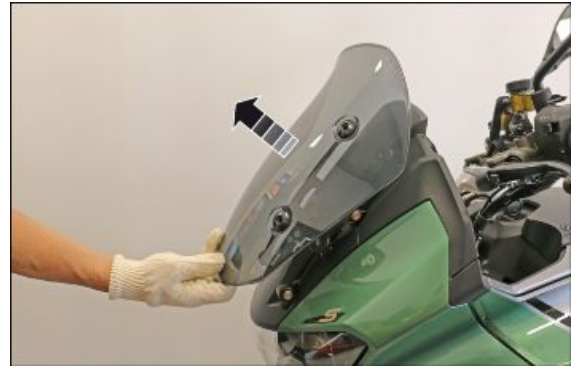

- Remove the five fixing screws of the lower front fairing element.

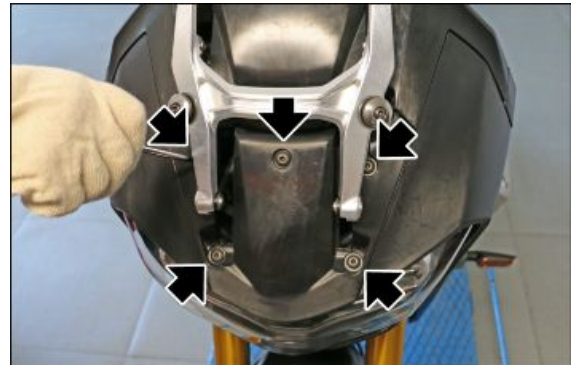

- Remove the front lower fairing from the vehicle, pulling it downward.



- Unscrew the two fixing screws of the right internal cover of the top fairing.

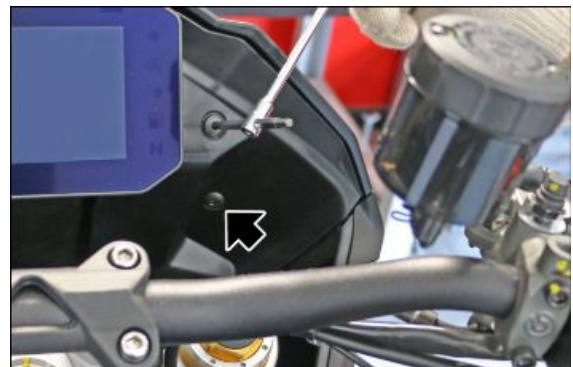

- Remove the right internal cover from the vehicle.
- Repeat the operation for the left cover.



- Remove the four fixing screws of the upper front fairing.



- Lifting with the hands the points indicated in the figure, release the front upper fairing (1) from the side fairings (2).

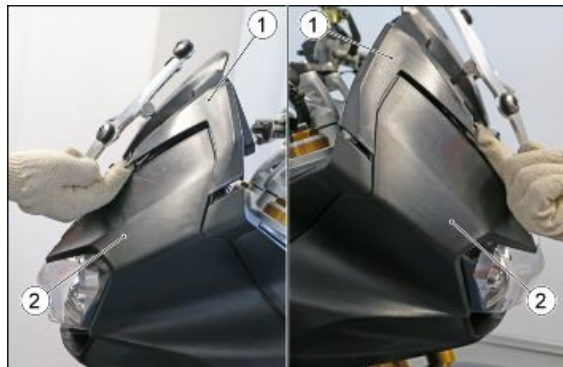

- Remove the front upper fairing from the vehicle sliding it upward.



- Retrieve the top fairing side moulding, on both sides.



Disassembling the lock

REMOVAL

- First remove the left fairing.
- Remove the screw (1) and the washer (2) fastening the lock lever.



- Lift the lever from the lock pawl lock and remove it.

NOTE

When removing, pay attention to the spring that is pre-loaded.



- Remove the spring from the pawl.



- Remove the pawl extracting it from the external side from the fairing.



- Remove the plate (3).



- Remove the clip fixing the pawl.



FITTING

- Insert the pawl in the left side fairing, taking care to insert the guide (4) into its seat of the fairing.



- Install the plate (3), taking care to insert the centring holes in the relative guides on the fairing.



- Install the fastening clips of the pawl.



- Install the spring on the pawl, taking care to insert the lower pin in its seat on the pawl.



- Insert the upper pin of the spring in the corresponding hole on the lever.
- Turn the lever to preload the spring and then insert the lever into its seat on the pawl.



- Install the washer (2) and tighten the fixing screw (1).



Taillight assy.

REMOVAL

- First remove the rear handle, the storage compartment and the panels of the tail fairing.
- Remove the rear screw (1) on both sides.

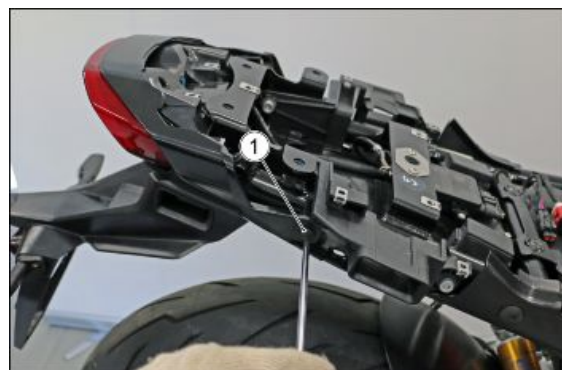

- Remove the four fixing screws (2) of the lower cover (3) of the licence plate holder.

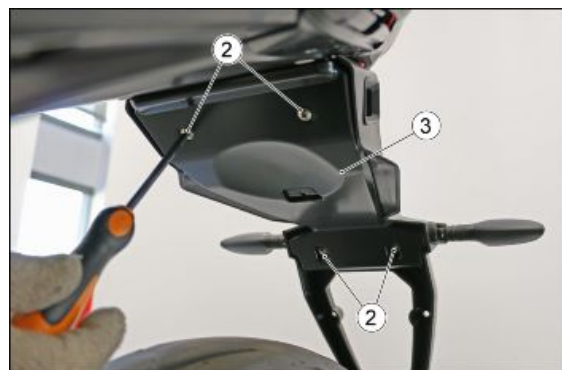

- Remove the cover (3) from the vehicle.



- Remove the lower fixing screw (4) of the rear light cluster.



- Remove the rear light cluster from its seat.



Disconnect the connector (5) and remove the light cluster from the vehicle.



License plate light

REMOVAL

- Remove the four fixing screws (1) of the lower cover (2) of the licence plate support.

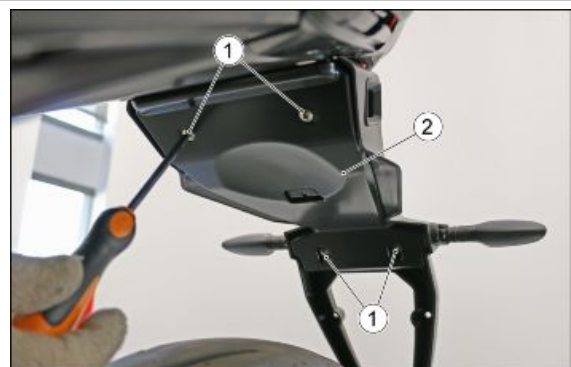

- Remove the cover (2) from the vehicle.



- Disconnect the license plate light connector (3).



- Remove the two fixing screws (4) and extract the license plate light (5) from the license plate support.



Rider footrest plate

RIGHT FOOTREST PLATE REMOVAL

- Remove the two rear brake pump fastener screws (1).



- Remove the pump from the footrest plate and fix it to the vehicle.



- Remove the upper fixing screw (2) and retrieve the washer (3).

During refitting, tighten the fixing screw to the prescribed torque.

Locking torques (N*m)

Footrest plate fixing screw $25 \pm 3.5 \text{ Nm}$ ($14.75 \pm 2.58 \text{ lb ft}$)



- Remove the two lower fixing screws (4) and retrieve the relative washers (5).

During refitting, tighten the fixing screws to the prescribed torque.

Locking torques (N*m)

Footrest plate fixing screw $25 \pm 3.5 \text{ Nm}$ ($14.75 \pm 2.58 \text{ lb ft}$)

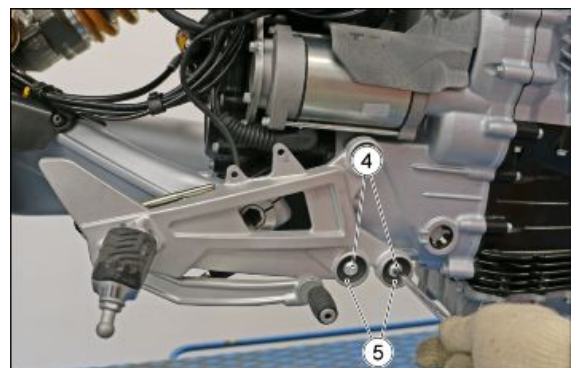

- Retrieve the bushings (6) from the lower fasteners of the footrest.

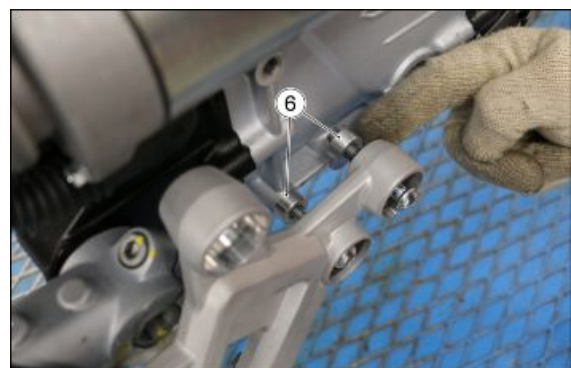

- Remove the screw (7) fixing the stop sensor to the footrest plate.

During refitting, tighten the fixing screw to the prescribed torque.

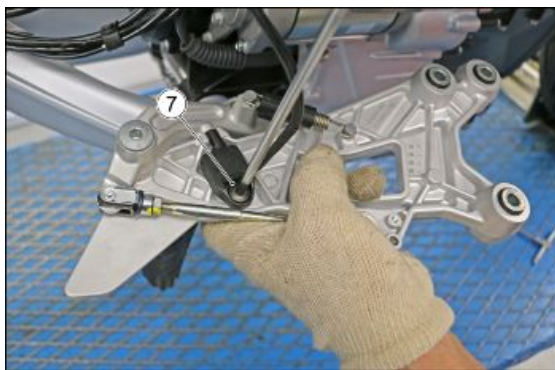

- Remove the right footrest plate from the vehicle.



REMOVING THE REAR BRAKE LEVER

- Remove the O. R. (1) from the fork of the rear brake actuator.



- Remove the safety pin (2) from the rear brake actuator fork.
- Remove the rear brake actuator from the brake lever.



- Release the return spring (3) of the lever from the right footrest bracket.
- Remove the spring (3) from the rear brake lever.

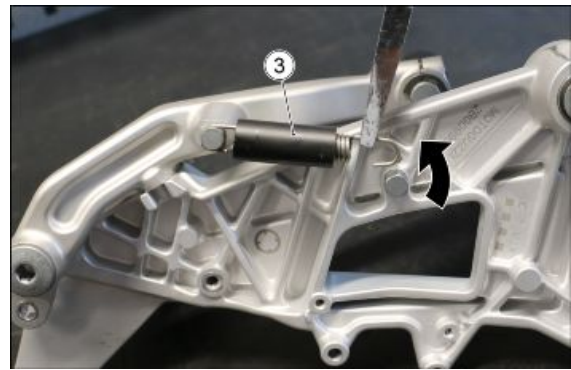

- Remove the screw / pin (4) fastening the rear brake lever.

During refitting, tighten the pin to the prescribed torque.



- Retrieve the pin (4), the two O. R. (5) and the washer (6).

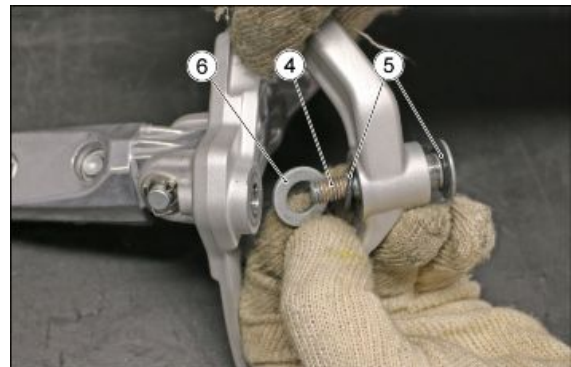

LEFT FOOTREST PLATE REMOVAL

- Remove the fixing screw (1) holding the nut (2).

During refitting, tighten the fixing screw to the prescribed torque.

Locking torques (N*m)

Footrest plate fixing screw 25 ± 3.5 Nm (14.75 ± 2.58 lb ft)



- Remove the screw (1) and retrieve the washer (3).

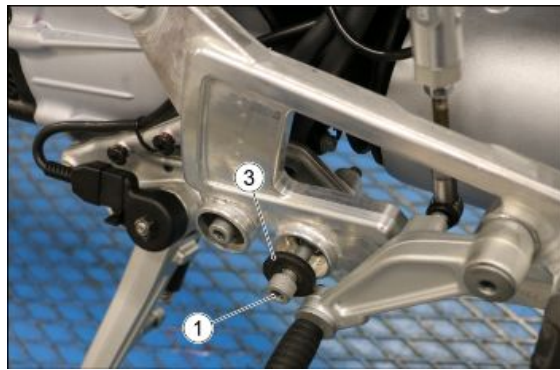

- Remove the fixing screw (4) and retrieve the washer (5).

During refitting, tighten the fixing screw to the prescribed torque.

Locking torques (N*m)

Footrest plate fixing screw 25 ± 3.5 Nm (14.75 ± 2.58 lb ft)



- Once the fixing screw is removed (4), retrieve the bushing (6) placed between the footrest and the engine block.



- Remove the upper fixing screw (7) and retrieve the washer (8).

During refitting, tighten the fixing screw to the prescribed torque.

Locking torques (N*m)

Footrest plate fixing screw 25 ± 3.5 Nm (14.75 ± 2.58 lb ft)

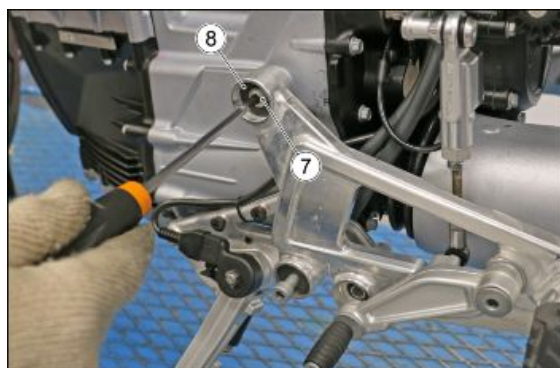

- Rotate the footrest to reach the transmission (9) of the gearbox lever and remove the safety clip (10).



- Remove the transmission (9) from the gearbox lever and remove the left footrest plate (11) from the vehicle.



REMOVING THE GEAR SHIFT LEVER

- Unscrew the screw / fixing pin (1), holding the nut (2).

During refitting, tighten the pin to the prescribed torque.



- Retrieve the nut (2) and the washer (3).



- Remove the gear lever from the footrest plate.
- Retrieve the pin (1), the O. R. (4) and the washer (5).

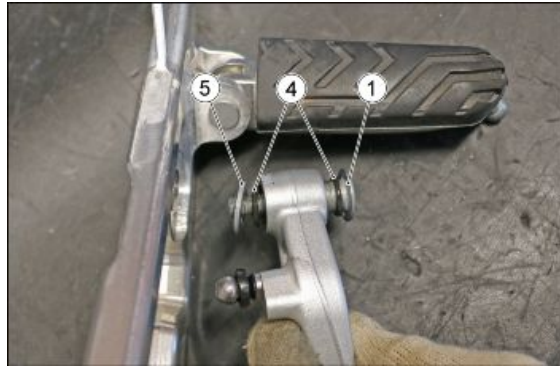

Passenger footrest plate

LEFT FOOTREST PLATE REMOVAL

- Remove the two fastening screws (1).

During refitting, tighten the fixing screws to the prescribed torque.

Locking torques (N*m)

Footrest plate fixing screw 25 ± 3.5 Nm (14.75 ± 2.58 lb ft)

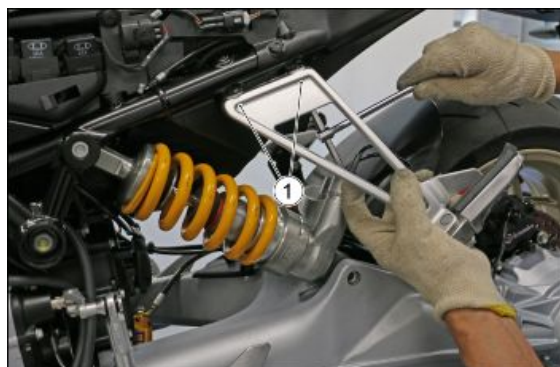

- Remove the left footrest plate from the vehicle.



RIGHT FOOTREST PLATE REMOVAL

- Holding the nut (1), unscrew the fixing screw (2) of the exhaust end.

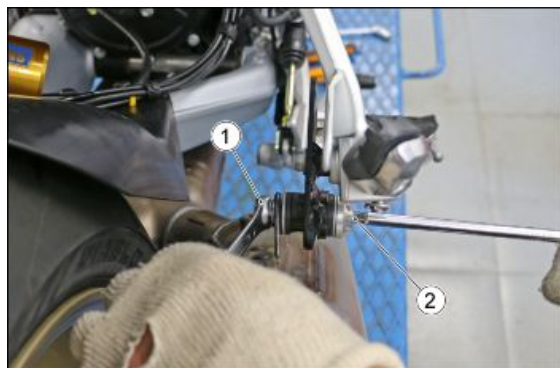

- Remove the two fastening screws (3).

During refitting, tighten the fixing screws to the prescribed torque.

Locking torques (N*m)

Footrest plate fixing screw 25 ± 3.5 Nm (14.75 ± 2.58 lb ft)



- Remove the right footrest plate from the vehicle.

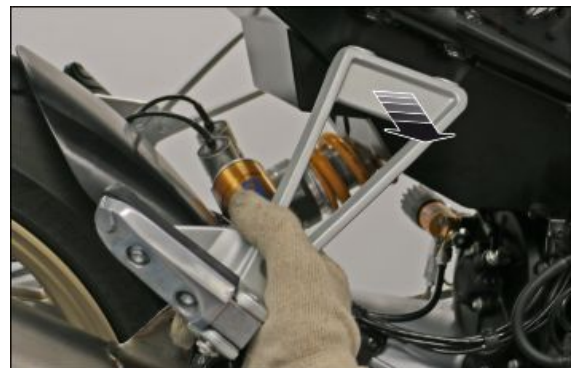

Footrest

NOTE

The following procedure is valid for both rider and passenger footrests and can be performed also with footrest plates fitted on the vehicle.

REMOVAL

- Remove the cotter pin (1).



- Collect the washer (2).



- Remove the pin (3) and remove the footrest from the footrest support plate.



- Retrieve the return spring (4) from the footrest.



REMOVING THE NON-SLIP RUBBER

- Remove the two screws (1)

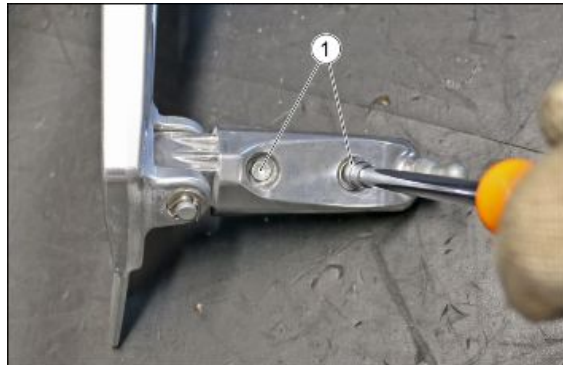

- Remove the non-slip rubber (2) from the footrest.



- Remove the fastening plate (3) from the anti-slip rubber (2).

NOTE

The left rubbers are marked with "L" and the right with "R" and can be fitted both for the rider and for the passenger.

**Side body panels****REMOVAL**

The operations described below refer to the left side fairing, but are valid for the right side fairing as well, excluding the operations concerning the saddle lock.

- First remove the rider saddle.
- Remove the two expansion caps.
- Release the fairing from the tank moving it toward the rear of the vehicle.
- Release the saddle opening cable from the support, by lifting it up.



- Remove the cable from the operating lever, then remove the fairing from the vehicle.



Glove-box

REMOVAL

- First remove the rear handle.
- Remove the five fixing screws.

NOTE

To remove the storage compartment it is not necessary to remove the tail fairing panels.

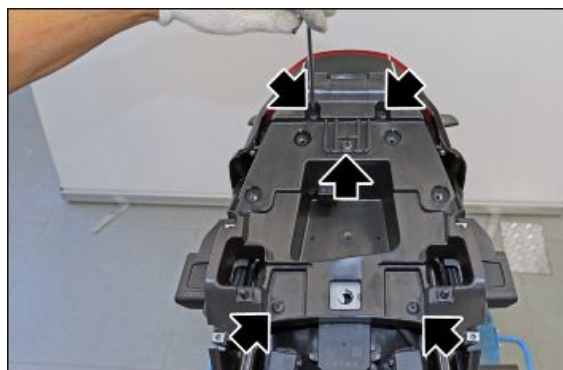

- Lift the storage compartment from the tail fairing.

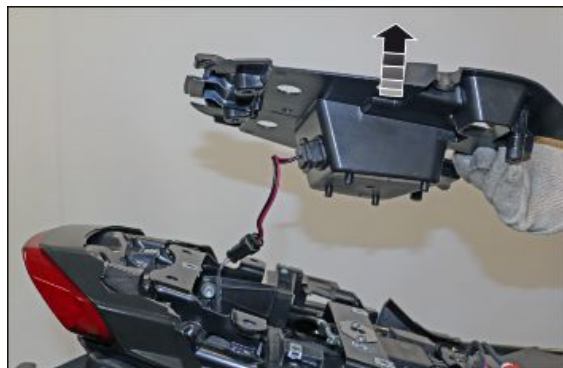

- Disconnect the USB port connector and remove the compartment from the vehicle.



Side fairings

REMOVAL

- First remove the top fairing.
- Remove the four fixing screws and then remove the cover of the tank (1) from the vehicle.

NOTE

THE OPERATIONS DESCRIBED BELOW REFER TO THE REMOVAL OF ONLY ONE SIDE PANELLING, BUT ARE VALID FOR BOTH.

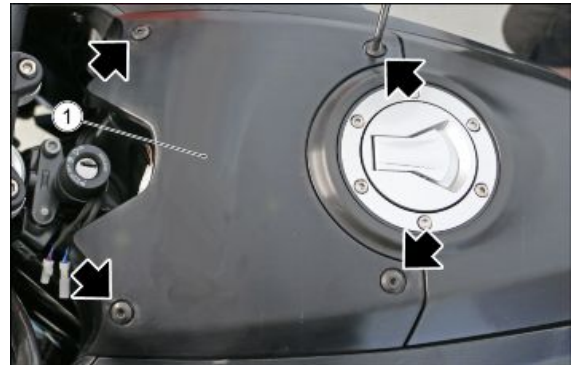

- Remove the expansion cap on the inside of the fairing.

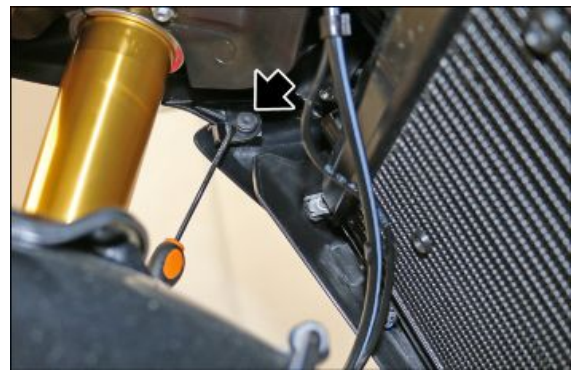

- Remove the fixing screws indicated in the figure.



- Remove the upper fixing screw.



- Remove the lower fastening screw.



- Remove the three rear fixing screws.

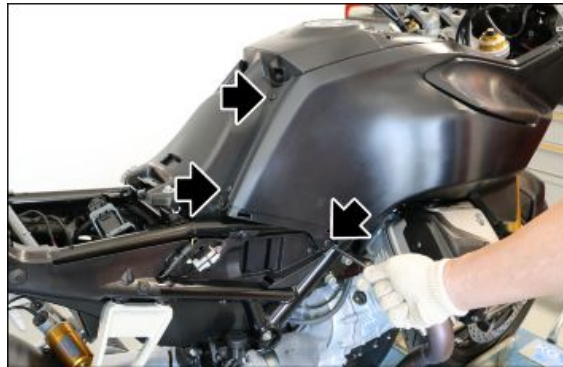

- Release the front fasteners by pulling the side fairing outward.



- Move the fairing toward the rear to release it from the fuel tank.



- Disconnect the connector of the aerodynamic guard's wiring harness, then remove the fairing from the vehicle.



AERODYNAMIC FLAP REMOVAL

Disconnect the battery and remove:

- top fairing
- front fairing cover;
- right and left instrument cluster;
- driver and passenger seat;
- fuel tank cover;
- left and right side fairing.



NOTE

THE FOLLOWING PROCEDURE IS ALSO VALID FOR THE FLAP ON THE OTHER SIDE OF THE VEHICLE.

Unscrew the 9 fixing screws of the inner cover.



Remove the complete inner cover with the supports and actuator.



Please note that there are washers on the 2 flap fixing screws.



Turn the fairing and remove the flap.



If necessary, remove the mushroom-shaped grommets from the fairing.



Place the complete inner cover with supports and actuator on a steady surface.

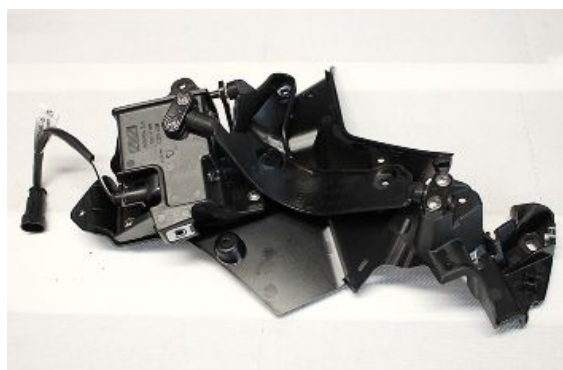

Unscrew the fixing screws of the first plate.



Remove the first plate.



Unscrew the fixing screws of the second plate.



Remove the second plate.



Remove the fixing cir-clip of the actuator connecting rod.



Remove the actuator connecting rod from the bracket.



Remove the mount.



Unscrew the fixing screws for the actuator assembly from the additional support.

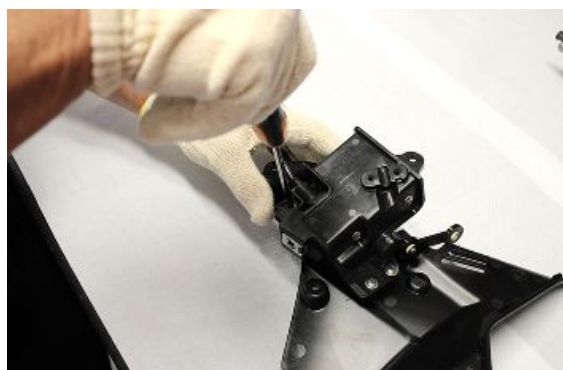

Remove the actuator assembly.



Unscrew the fixing screws for the actuator assembly from the actuator bracket.



Remove the actuator assembly.



FITTING

For reassembly, carry out the operations described for removal in reverse order, paying particular attention to the mounting of the plates.

These in fact have a tooth that must be correctly positioned in its slot on the inner cover.



Once the flap has been inserted, before refitting the inner cover, grease the seat for the 2 washers properly.



Place the 2 washers on their respective seats on the flap, then proceed to fixing the inner cover.



Fairing mounting panels

REMOVING THE RIGHT HAND UNDER-FAIRING

- First remove the right side fairing.
- Remove the fixing screw (1).



- Remove the fixing screw (2).

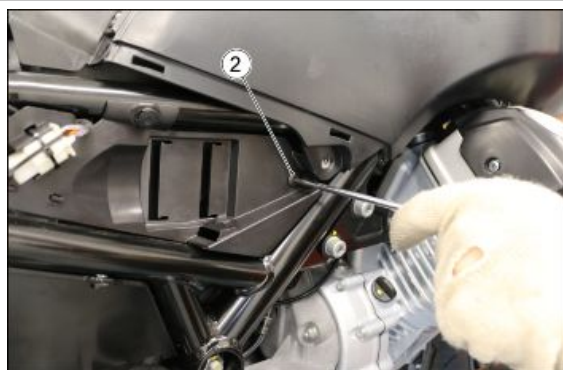

- Remove the expansion cap (3).



- Remove the expansion cap (4).

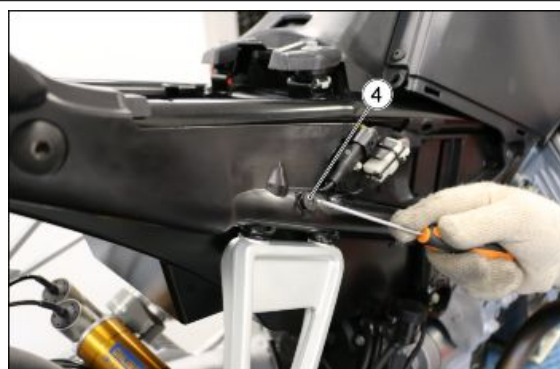

- Remove the fixing screw (5).



- Move the under-fairing forward to remove it from the tail fairing.



- Disconnect the connector (6).

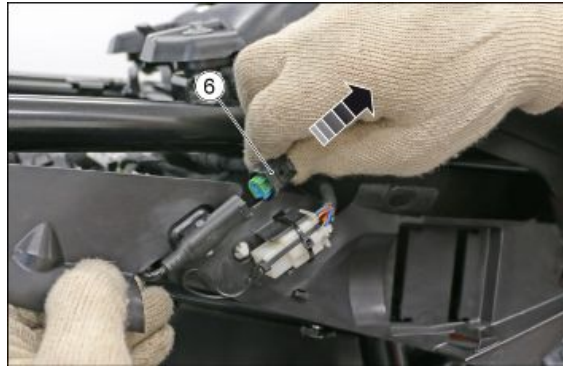

- Operating from the internal side, remove the clip fastening the connector (6) to the under-fairing.



- Cut the plastic clamp (7) as shown in the figure.



- Remove the connector (8) from the under-fairing.



- Press the fixing clip (9) with the clamps and remove it from the under-fairing.



- Remove the right under-fairing from the vehicle.



REMOVING THE LEFT HAND UNDER-FAIRING

- First remove the left side fairing.
- Remove the fixing screw (1).

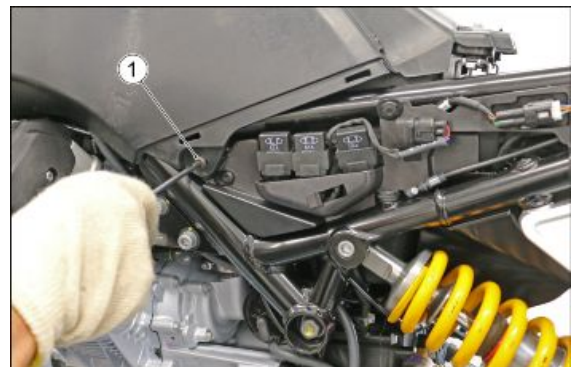

- Remove the fixing screw (2).

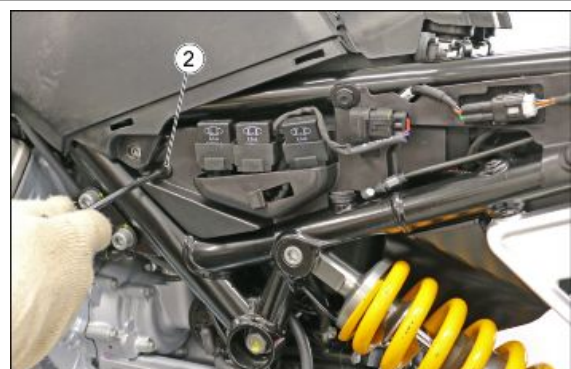

- Remove the expansion cap (3).



- Remove the expansion cap (4).



- Remove the fixing screw (5).



- Move the under-fairing forward to remove it from the tail fairing.



- Remove the connector (6) from its support on the under-fairing.



- Operating from the internal side, remove the clip (7) fastening the connector to the under-fairing.



- Remove the left under-fairing from the vehicle.



License plate holder

REMOVAL

- First remove the tail fairing, the storage compartment and the rear light cluster.
- Disconnect the connectors of the licence plate light and of the rear turn indicators.
- Remove the four fixing screws (1).



- Remove the license plate holder (2) from the vehicle.



Air box

- First remove the fuel tank.
- Loosen the two clamps (1) of the throttle body manifolds.



- Open the clamp and disconnect the left breather pipe (2) from the filter box.



- Remove the left fixing screw of the filter box.

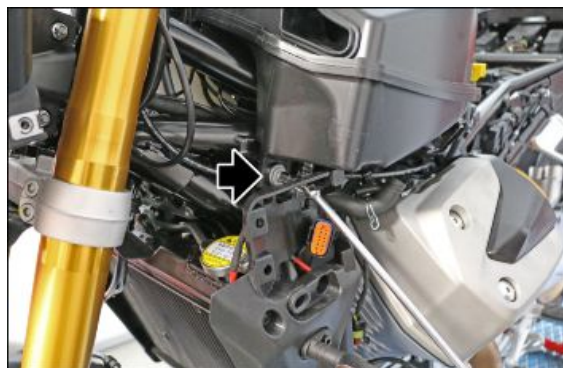

- Open the clamp and disconnect the right breather pipe (3) from the filter box.



- Remove the right fixing screw of the filter box.

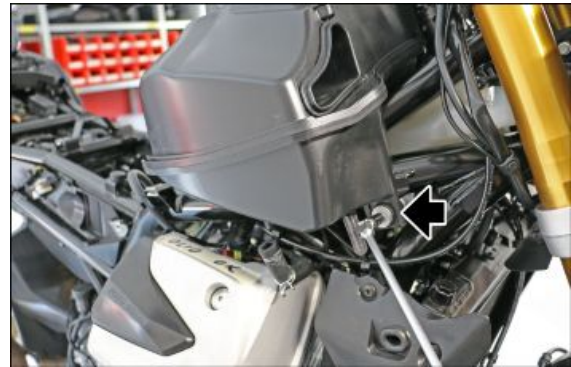

- Remove the filter box from the vehicle by extracting it upward.



DURING REASSEMBLY, ENSURE THE CORRECT INSERTION OF THE AIR FILTER HOUSING MANIFOLDS ON THE THROTTLE BODIES.



- To remove the air filter inside the filter box, carry out the procedure described in paragraph "air filter" in the "maintenance" chapter.

See also

Air filter

Fuel tank

FUEL TANK COVER

REMOVAL

- First remove the rider saddle and the side fairings.
- Open the tank plug.
- Remove the three external fixing screws (1).

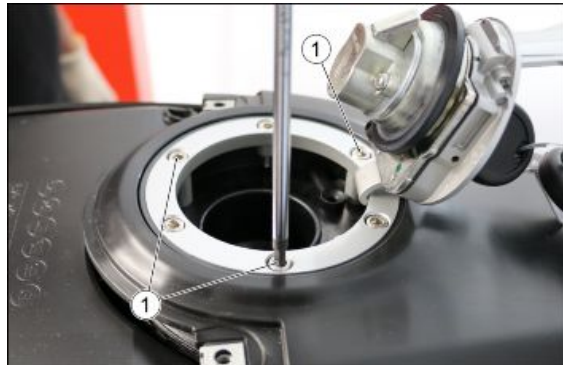

- Remove the internal fixing screw (2).

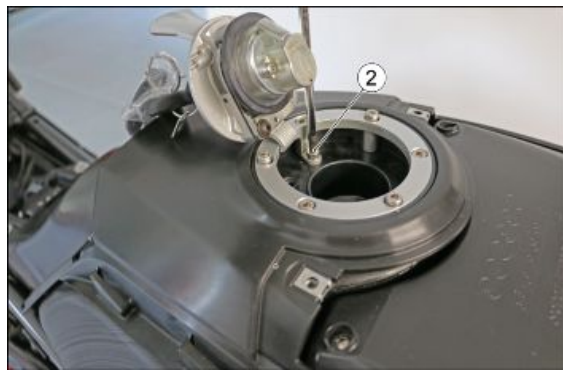

- Remove the tank cap from the tank itself.



- - Remove the two rear fixing screws.

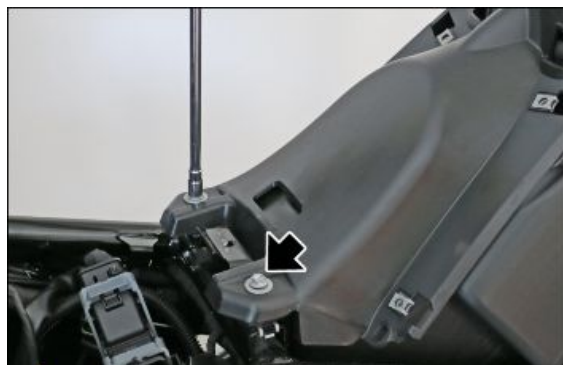

- Remove the two fixing screws on the right side of the tank.

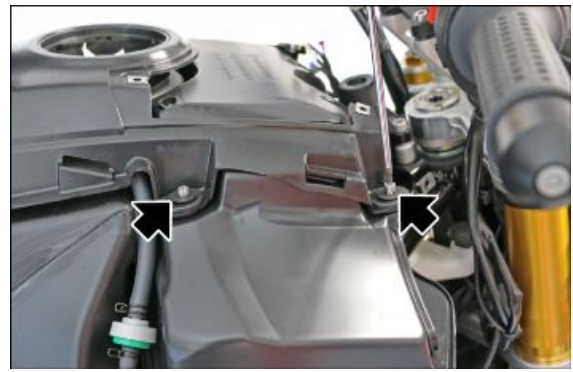

- Remove the two fixing screws on the left side of the tank.

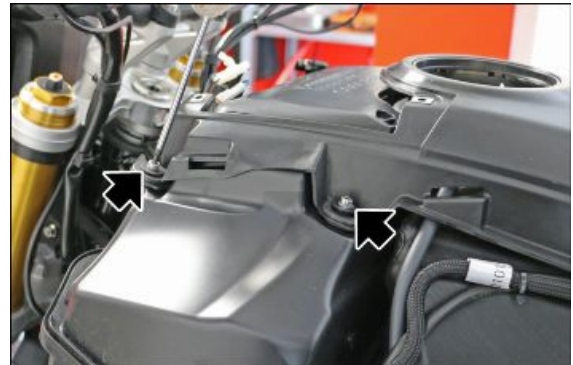

- Remove the tank cover from the vehicle, lifting it upward.

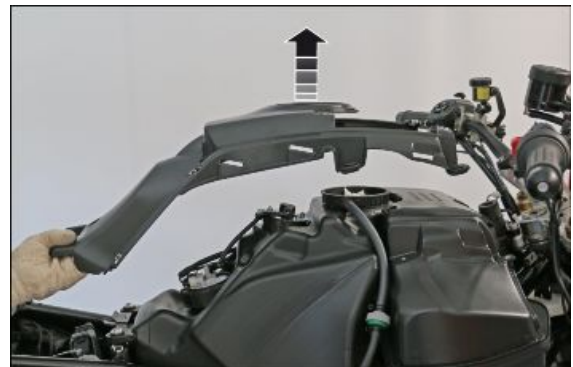

FUEL TANK

REMOVAL

- Remove the tank cover.
- Open the spring clamp (1) on both sides.

CAUTION
BEFORE REMOVING THE TANK, EMPTY IT OF ALL GASOLINE



- Remove the vent pipe (2), on both sides.



- Remove the safety tab from the fuel pipe quick coupling.



- Press the fuel coupling on the sides and simultaneously extract the pipe from the coupling.



- Disconnect the connector of the fuel pump / fuel level sensor wiring harness.



- Remove the left-hand fixing screw.

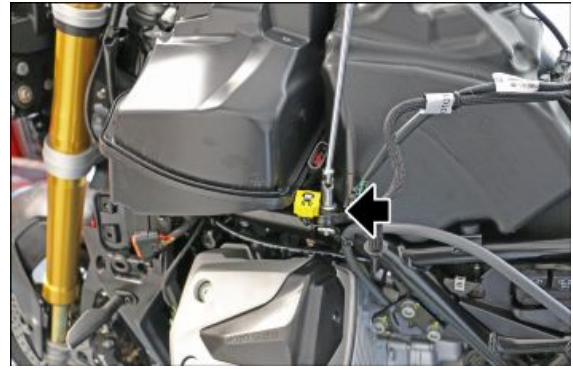

- Remove the right-hand fixing screw.

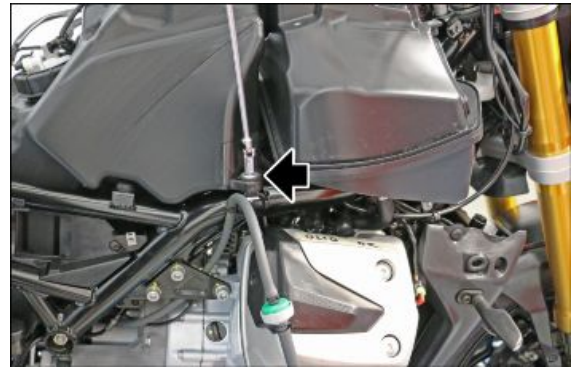

- Remove the tank from the vehicle pulling it upward.



FUEL LEVEL SENSOR

NOTE

The fuel level sensor can be removed even if the tank is mounted on the vehicle. The procedure is the same as that described below, just remove the tank cover.

REMOVAL

- Disconnect the connector.



- Remove the fixing nuts (1) of the flange (2).

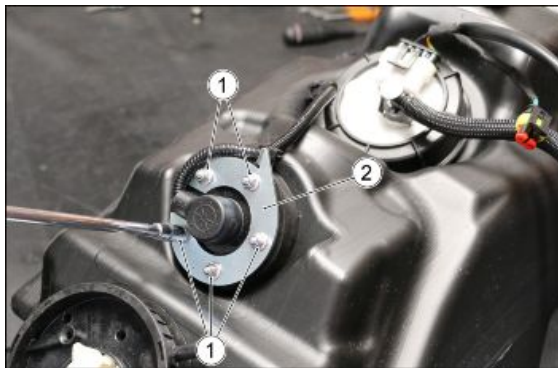

- Remove the flange (2) from the sensor (3).



- Remove the sensor (3) from the tank and retrieve the gasket (4).



Rear wheelhouse

REMOVAL

- Preventively remove: The battery, the control unit, the tail fairing, the storage compartment, the rear light cluster and the license plate support.
- Unscrew the screw fixing the rear brake oil tank.



- Remove the internal fixing screw (1), which can be reached from inside the battery compartment.

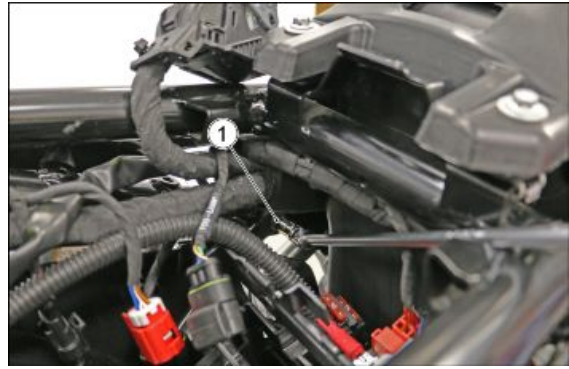

- Remove the wiring harnesses from the two cable glands shown in the figure.



- Extract the secondary fuse boxes from the relative supports on the wheel arch.



- Remove the fixing screw (2).
- Repeat on the opposite side.

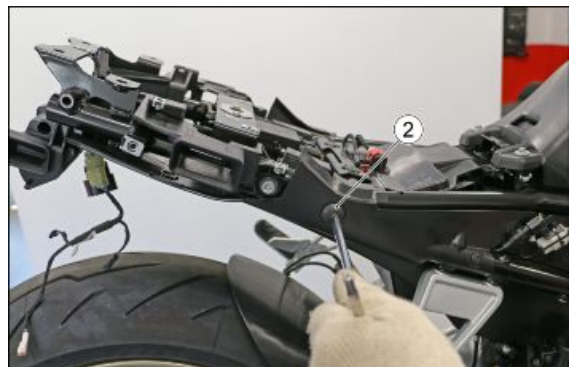

- Remove the expansion cap (3).
- Repeat on the opposite side.



- Move the cover of the rear frame, in order to remove the right fixing screw (4) of the wheel arch.



- Move the cover of the rear frame, in order to remove the left fixing screw (5) of the wheel arch.



- Remove the lower fixing screw (6) on the right side of the wheel arch.

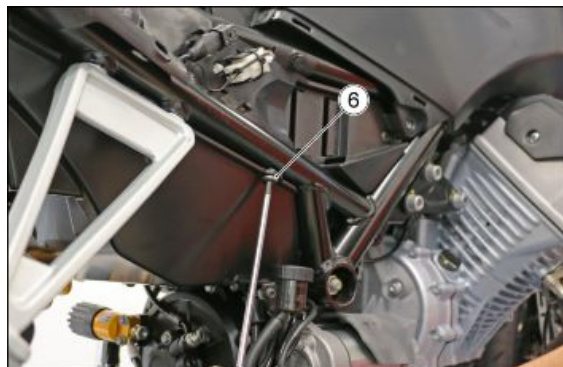

- Remove the two rear screws (7).



- Lower the wheel arch and place it on the rear wheel.
- Disconnect the connectors (8) and (9).



- Extract the starter relay (10) from its support on the wheel arch.



- Extract the main fuse (11) from its support on the wheel arch.



- Remove the fixing nut and remove the SAS valve (12) from the wheel arch.



- Disconnect the connector (13).



- Remove the rear wheelhouse from the vehicle.



Front mudguard

REMOVAL

- Remove the hose guide (1) from the rear side of the mudguard.

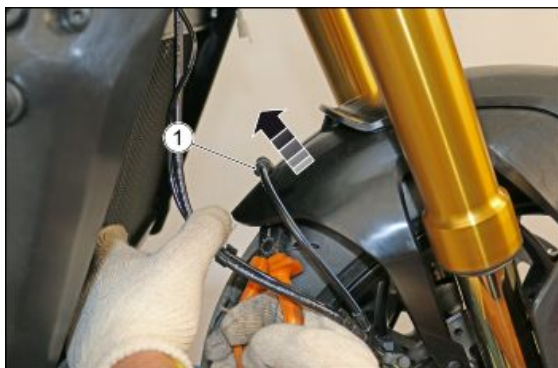

- Remove the two RH fixing screws.



- Remove the two LH fixing screws.



- Remove the front mudguard (2) from the vehicle.



Pannier mounting

REMOVAL

- First remove the tail fairing, the storage compartment, the rear light cluster and the license plate support.
- Remove the two screws (1) fastening the wheel housing to the side panniers supports.



- Remove the two screws (2) that join the left and right supports.



- Remove the fixing screw (3).

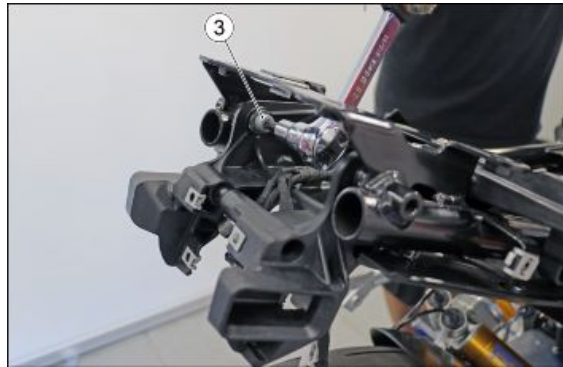

- Remove the fixing screw (4).

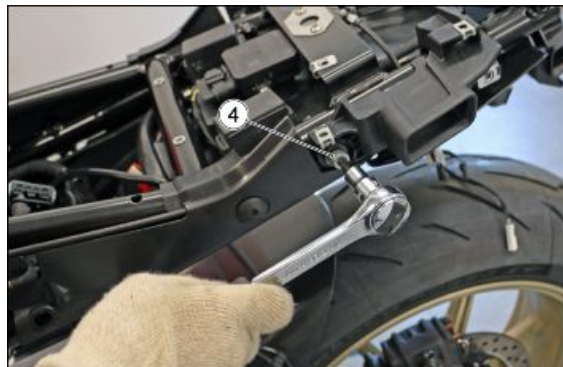

- Remove the left support (5) from the vehicle.

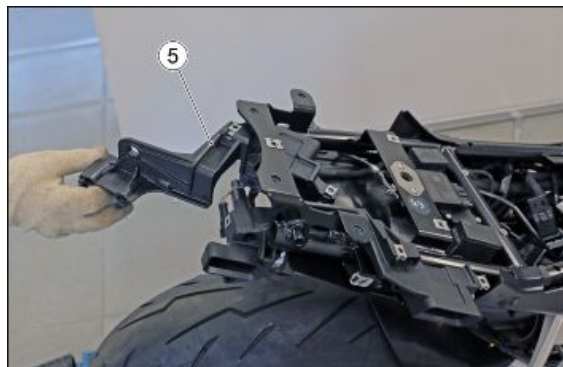

- Remove the fixing screw (6).

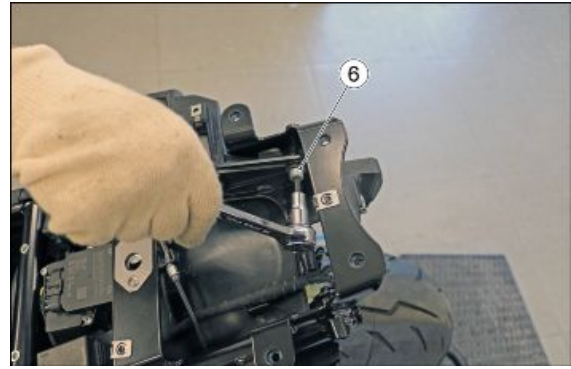

- Remove the fixing screw (7).



- Remove the right support (8) from the vehicle.



Rear grab rail

REMOVAL

- Remove the passenger saddle.
- Remove the four fixing screws (1).

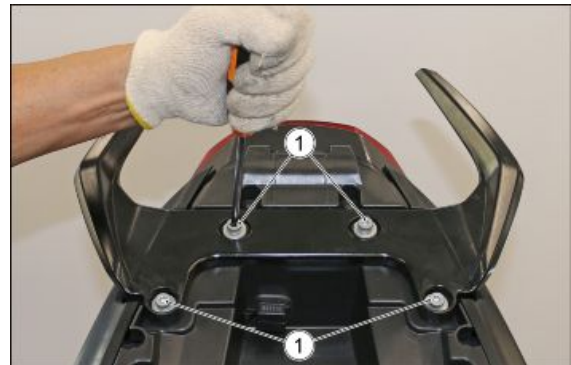

- Remove the rear handle (2) from the vehicle.



Instrument cluster support

REMOVAL

- First remove the front light assembly and the instrument panel.
- Remove the connectors (1) and (2) on the right side of the instrument panel mount.

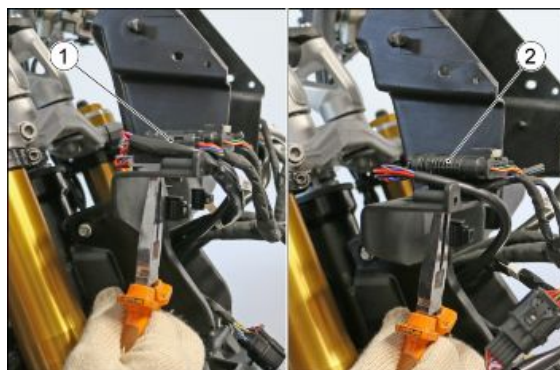

- Remove the connector (3) on the left side of the instrument panel mount.



- Release the connector (4) from the relative slide on the instrument panel.



- Unscrew the upper fixing screw (5) and the relative lock nut and retrieve the two T-bushings.

During refitting, tighten the nut to the prescribed torque.

Locking torques (N*m)

Upper fixing screw (5) 10 Nm (7.38 lbf ft)



- Unscrew the upper fixing screw (6) and the relative lock nut and retrieve the two T-bushings.

During refitting, tighten the nut to the prescribed torque.

Locking torques (N*m)

Lower fixing screw (6) 10 Nm (7.38 lbf ft)

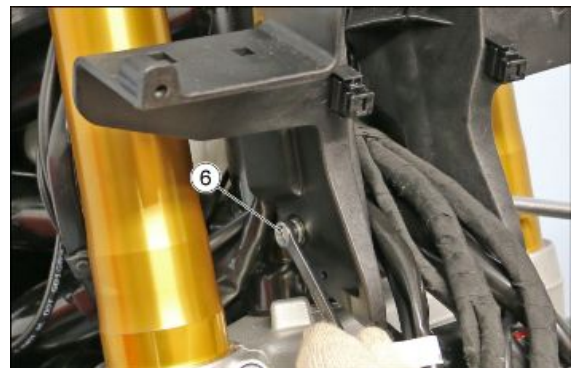

- Remove the instrument panel support from the vehicle, sliding the wiring harnesses inside it.



Battery

- Make sure the ignition switch is set to "KEY OFF";
- Remove the rider saddle;
- Disconnect the connector (1) of the OBD2 socket;
- Remove the cable (2) of the GMP provision, moving it forward to release it from its support;

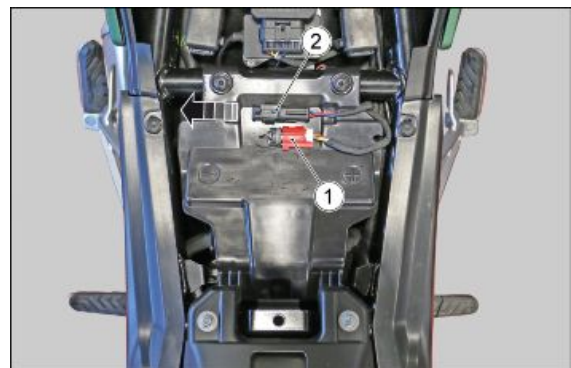

- Remove the two fixing screws (3);

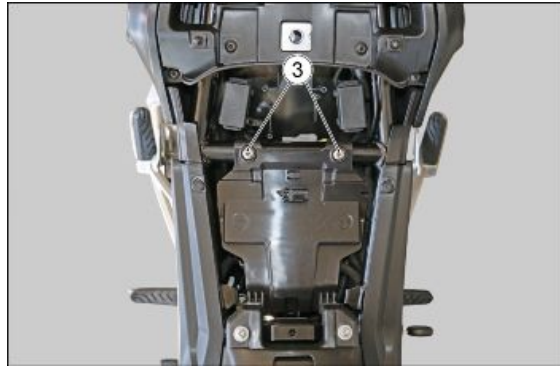

- Release the plastic securing the battery from its mountings to the tank and remove it by bringing it toward the rear of the vehicle.

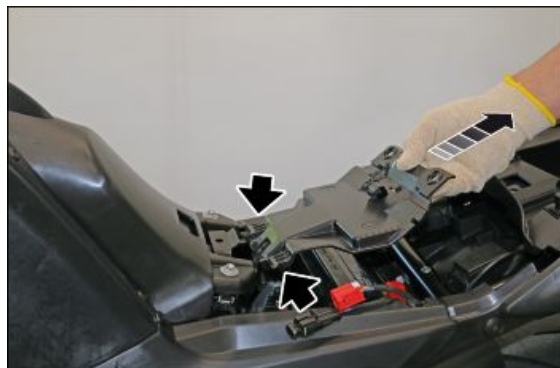

- Unscrew and remove the screw (4) from the negative terminal (-).
- Move the negative lead (5) aside.
- Move the protection cap (6), unscrew and remove the screw (7) from the positive terminal (+).
- Move the positive lead (8) aside.
- Grip the battery firmly and remove from its seat.
- Put the battery away on a level surface, in a cool and dry place.

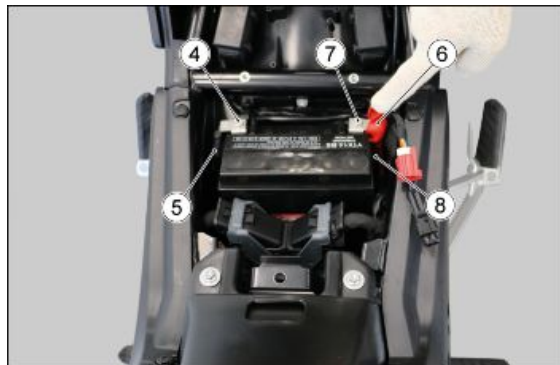

CHECK THAT THE CABLE TERMINALS AND BATTERY LEADS ARE:

- IN GOOD CONDITION (NOT CORRODED OR COVERED BY DEPOSITS);
- COVERED BY NEUTRAL GREASE OR PETROLEUM JELLY.



REMOVING THE BATTERY RESETS THE DIGITAL CLOCK AND THE TRIP JOURNAL FUNCTIONS.

CAUTION



ONCE REMOVED, THE BATTERY MUST BE PUT AWAY IN A SAFE PLACE OUT OF THE REACH OF CHILDREN.

INSTALLATION

- Follow the removal procedure in reverse order; be careful to FIRST CONNECT THE POSITIVE CABLE (+) and then the negative cable (-).

Tail guard

REAR FAIRINGS REMOVAL

- First remove the passenger saddle, the rider saddle and the rear handle.
- Remove the two upper fixing screws.



- Remove the lower fastening screw.



- Pull outward the front part of the fairing and bring it toward the tank to release it from the support then remove it from the vehicle.

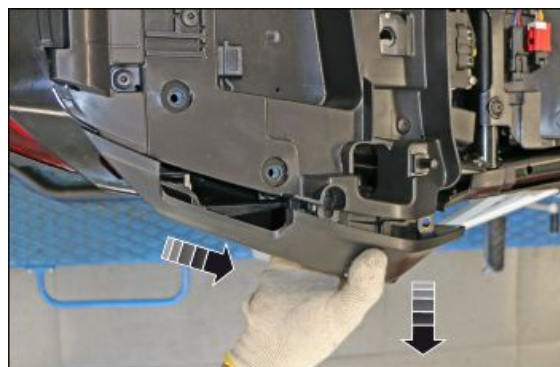

- When refitting, first insert the rear tooth securing the fairing into its housing on the tail light.
- Repeat the operations for the fairing on the opposite side.



A

ABS: 284

Air filter: 71–73, 387

B

Battery: 110, 133, 401

Brake: 289, 291, 293, 295, 297, 299, 308, 314–316

Brake calliper: 289, 291

Brake disc: 293, 295

Brake fluid: 308

Brake pads: 297, 299

Brake pump: 314, 315

Bulbs:

C

CAN line: 152

Cardan shaft: 250

Clutch: 85, 146, 327, 329

Coil: 141

coolant: 331

Coolant: 331

Cylinder: 327, 329

E

ECU:

Electric fan: 148

Electrical system: 7, 23, 91

Engine oil: 66

Engine temperature sensor: 136

Exhaust: 276, 278

Exhaust manifold: 278

F

Fairings: 373

Fork: 182, 183, 188, 197

Front wheel: 236

Fuel: 140, 165, 388

Fuel pump: 140, 165

Fuses: 115

H

Handlebar: 176

Headlight: 85, 349, 354

Horn: 351

I

Identification: 21

Instrument panel: 347

Intake pressure sensor: 135

K

Keys: 106

L

License plate holder: 385

M

Maintenance: 18, 59, 107, 288

Mirrors:

Mudguard: 396

O

Oil filter: 69

Oil pressure sensor: 144

R

Radiator: 334

Rear wheel: 246

Recommended products: 61

S

SAS valve actuator: 148

Scheduled maintenance: 59

Shock absorber:

Shock absorbers: 221

Side fairings: 373

Side stand: 147, 275

Side stand sensor: 147

Spark plug: 61

Spark plugs:

Stand: 147, 274, 275

Start-up: 113

T

Tank: 338, 388

Throttle body: 142, 167, 171

Top fairing:

Transmission: 22, 63

Turn indicators: 352

Tyres: 24